

**SCHEME :K**

Name : \_\_\_\_\_  
Roll No.: \_\_\_\_\_ Year : 20 \_\_\_\_ 20 \_\_\_\_  
Exam Seat No. : \_\_\_\_\_

# LABORATORY MANUAL FOR SWITCHGEAR AND PROTECTION (315334)

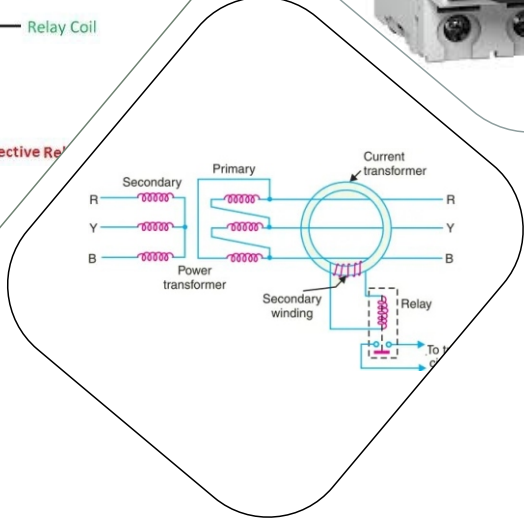
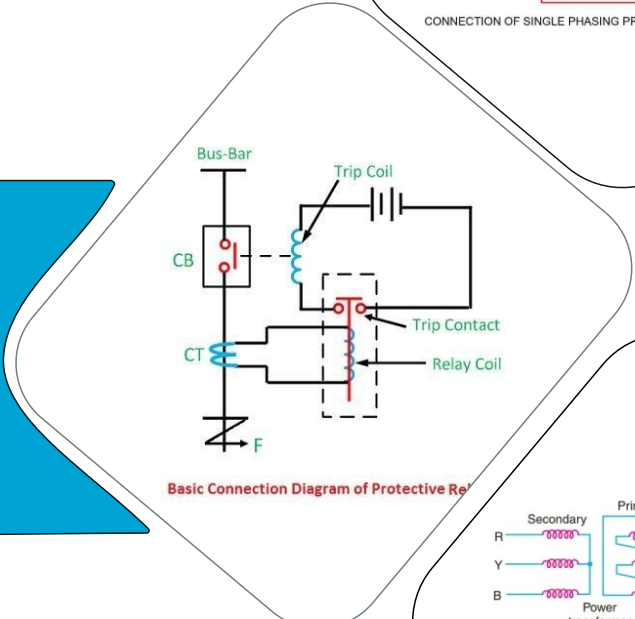
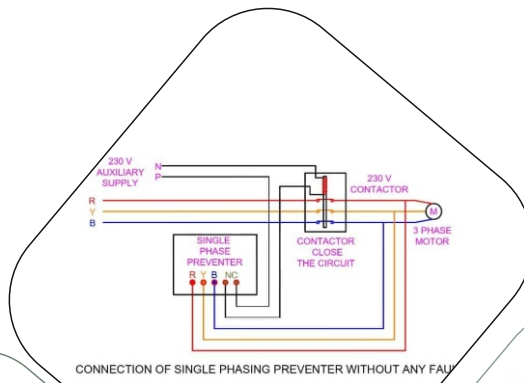

**ELECTRICAL ENGINEERING GROUP**



**MAHARASHTRA STATE BOARD OF  
TECHNICAL EDUCATION, MUMBAI  
(Autonomous)(ISO21001:2018)(ISO/IEC27001:2013)**

## **VISION**

To ensure that the Diploma level Technical Education constantly matches the latest requirements of Technology and industry and includes the all-round personal development of students including social concerns and to become globally competitive, technology led organization.

## **MISSION**

To provide high quality technical and managerial manpower, information and consultancy services to the industry and community to enable the industry and community to face the challenging technological & environmental challenges.

## **QUALITY POLICY**

We, at MSBTE are committed to offer the best in class academic services to the students and institutes to enhance the delight of industry and society. This will be achieved through continual improvement in management practices adopted in the process of curriculum design, development, implementation, evaluation and monitoring system along with adequate faculty development programmes.

## **CORE VALUES**

### **MSBTE believes in the following:**

- Education industry produces live products.
- Market requirements do not wait for curriculum changes.
- Question paper is the reflector of academic standards of educational organization.
- Well-designed curriculum needs effective implementation too.
- Competency based curriculum is the backbone of need based program.
- Technical skills do need support of life skills.
- Best teachers are the national assets.
- Effective teaching learning process is impossible without learning resources.

**A Laboratory Manual For**

# **SWITCHGEAR AND PROTECTION**

**(315334)**

**Semester – V**

**(EE/EP)**



**Maharashtra State**  
**Board of Technical Education, Mumbai**  
**(Autonomous) (ISO 21001:2018)(ISO/IEC 27001:2013)**



**Maharashtra State Board of Technical Education, Mumbai**  
**(Autonomous) (ISO21001:2018) (ISO/IEC 27001:2013)**  
**4<sup>th</sup> Floor, Government Polytechnic Building, 49, Kherwadi,**  
**Bandra (East), Mumbai- 400051.**



**MAHARASHTRA STATE  
BOARD OF TECHNICAL EDUCATION**

**Certificate**

This is to certify that Mr. /Ms .....

Roll No. ...., of Fifth Semester of Diploma in  
..... of Institute,  
.....

(Code : .....) has completed the term work satisfactorily in course  
**Switchgear and Protection (315334)** for the academic year 20.....to 20.....  
as prescribed in the curriculum.

**Place:** .....

**Enrollment No:** .....

**Date:** .....

**Exam Seat No:** .....

**Course Teacher**

**Head of department**

**Principal**





## Preface

The primary focus of any engineering laboratory/field work in the technical education system is to develop the much-needed industry relevant competencies and skills. With this in view, MSBTE embarked on this innovative 'K' Scheme curricula for engineering diploma programmes with outcome-based education as the focus and accordingly, relatively large amount of time is allotted for the practical work. This displays the great importance of laboratory work making each teacher, instructor and student to realize that every minute of the laboratory time need to be effectively utilized to develop these outcomes, rather than doing other mundane activities. Therefore, for the successful implementation of this outcome-based curriculum, every practical has been designed to serve as a 'vehicle' to develop this industry identified competency in every student. The practical skills are difficult to develop through "chalk and duster" activity in the classroom situation. Accordingly, the 'K' scheme laboratory manual development team designed the practicals to focus on the outcomes, rather than the traditional age-old practice of conducting practicals to 'verify the theory' (which may become a byproduct along the way).

This laboratory manual is designed to help all stakeholders, especially the students, teachers and instructors to develop in the student the pre-determined outcomes. It is expected from each student that at least a day in advance, they have to thoroughly read through the concerned practical procedure that they will do the next day and understand the minimum theoretical background associated with the practical. Every practical in this manual begins by identifying the industry/employer expected outcome, course level learning outcome, laboratory learning outcome, which serve key focal point for doing the practical. The students will then become aware about the skills they will achieve through procedure shown there and necessary precautions to be taken, which will help them to apply in solving real-world problems in their professional life.

This manual also provides guidelines to teachers and instructors to effectively facilitate student-centered lab activities through each practical exercise by arranging and managing necessary resources in order that the students follow the procedures and precautions systematically ensuring the achievement of outcomes in the students.

The electrical diploma holder has to work in industry as technical person in middle level management. He has to work as production, maintenance, testing engineer in various industries like power generation, transmission, distribution, traction etc. and has to deal with different faults. While performing above task he has to identify different faults and repair them, therefore he/she must require the skills to deal with various parameters of the power system during normal and abnormal situation.

Although best possible care has been taken to check for errors (if any) in this laboratory manual, perfection may elude us as this is the first edition of this manual. Any errors and suggestions for improvement are solicited and highly welcome.

## **Program Outcomes (POs) to be achieved through this course learning**

- **PO 1. Basic and Discipline specific knowledge:** Apply knowledge of basic mathematics, sciences and engineering fundamentals with electrical engineering specialization to solve the engineering problems.
- **PO 2. Problem analysis:** Identify and analyze well-defined engineering problems using codified standard methods.
- **PO 3. Design/ development of solutions:** Design solutions for well-defined technical problems and assist with the design of system components or processes to meet specified needs.
- **PO 4. Engineering tools, Experimentation and Testing:** Apply modern engineering tools and appropriate technique to conduct standard tests and measurements.
- **PO 5. Engineering practices for society, sustainability and environment:** Apply appropriate technology in context of society, sustainability, environment and ethical practices.
- **PO 6. Project Management:** Use engineering management principles individually, as a team member or a leader to manage projects and effectively communicate about well-defined engineering activities.
- **PO 7. Life-long learning:** Ability to analyse individual needs and engage in updating in the context of technological changes.

### **List of relevant expected psychomotor domain skills**

This Lab manual intends to develop expected psychomotor domain skills of students. The skills mentioned below will be developed through the experiments performed in this Laboratory.

1. Sketching and collection of specifications.
2. Simulate the circuit configuration to create various faults.
3. Set relays for various fault level.
4. Handling and installation of various equipments.
5. Testing of various characteristics of machines with standards.

**Practical Course Outcome matrix**

<b>Course level learning outcomes (COs)</b>						
CO1 - Recognize the different types of faults occurring in power system.						
CO2 - Select the suitable switchgears for different applications.						
CO3 - Test the performance of different protective relays.						
CO4 - Use suitable protection schemes for alternators, motors, transformers, busbars and transmission lines.						
CO5 - Select suitable protection schemes for power system against over voltages.						
<b>Sr. No.</b>	<b>Title of the Practical</b>	<b>CO1</b>	<b>CO2</b>	<b>CO3</b>	<b>CO4</b>	<b>CO5</b>
1	*Simulation of Earth Fault/ Short Circuit fault.	✓	-	-	-	-
2	*Testing of HRC Fuse.	-	✓	-	-	-
3	*Testing of Miniature Circuit Breaker.	-	✓	-	-	-
4	*Characteristics of Induction type over-current relay.	-	-	✓	-	-
5	*Plug Setting and Time setting Multiplier of Induction type relay.	-	-	✓	-	-
6	*Demonstrate/ Simulate differential protection scheme for different types of faults on Alternator.	-	-	-	✓	-
7	*Demonstrate/ Simulate differential protection scheme for different types of faults on Transformer.	-	-	-	✓	-
8	*Testing of single-phase preventer for protecting three phase induction motor.	-	-	-	✓	-
9	Demonstrate/Simulate transmission line protection by using the impedance/over current relay for various faults.	-	-	-	✓	-
10	*Demonstration of Thyrite type lightning arrester using video /Dismantling the same.	-	-	-	-	✓
11	Demonstrate process of carrying out neutral earthing at different substations / locations or with suitable media	-	-	-	-	✓

### **Guidelines to Teachers**

1. Teacher should provide the guideline with demonstration of practical to the students with all features.
2. Teacher shall explain prior concepts to the students before starting of each experiment involve students in performance of each experiment.
3. Teacher should ensure that the respective skills and competencies are developed in the students after the completion of the practical exercise.
4. Teachers should give opportunity to students for hands on experience after the demonstration.
5. Teacher is expected to share the skills and competencies to be developed in the students.
6. Teacher may provide additional knowledge and skills to the students even though not covered in the manual but are expected the students by the industry.
7. Finally give practical assignment and assess the performance of students based on task assigned to check whether it is as per the instructions.

### **Instructions for Students**

1. Listen carefully the lecture given by teacher about subject, curriculum, learning structure, skills to be developed.
2. Organize the work in the group and make record all programs.
3. Students shall develop maintenance skill as expected by industries.
4. Student shall attempt to develop related hand-on skills and gain confidence.
5. Student shall develop the habits of evolving more ideas, innovations, skills etc. those included in scope of manual.
6. Student shall refer technical magazines.
7. Student should develop habit to submit the practicals on date and time.
8. Student should well prepare while submitting write-up of exercise.
9. Attach/paste separate papers wherever necessary.

## Content Page

### List of Practical's and Progressive Assessment Sheet

Sr. No.	Title of the Practical	Page no.	Date of Performance	Date of Submission	Assessment Marks (25)	Dated sign. of Teacher	Remarks ( If any)
1.	*Simulation of Earth Fault/ Short Circuit fault.	1					
2.	*Testing of HRC Fuse.	8					
3.	*Testing of Miniature Circuit Breaker.	15					
4.	*Characteristics of Induction type over-current relay.	22					
5.	*Plug Setting and Time setting Multiplier of Induction type relay.	29					
6.	*Demonstrate/ Simulate differential protection scheme for different types of faults on Alternator.	35					
7.	*Demonstrate/ Simulate differential protection scheme for different types of faults on Transformer.	41					

8.	*Testing of single-phase preventer for protecting three phase induction motor.	48					
9.	Demonstrate/Simulate transmission line protection by using the impedance/over current relay for various faults.	53					
10.	*Demonstration of Thyrite type lightning arrester using video /Dismantling the same.	58					
11.	Demonstrate process of carrying out neutral earthing at different substations / locations or with suitable media	64					
<b>Total</b>							

**Note: Out of above suggestive LLOs -**

\*' Marked Practicals (LLOs) Are mandatory.

Minimum 80% of above list of lab experiment are to be performed.

Judicial mix of LLOs is to be performed to achieve desired outcomes.

**Practical No. 1: Simulation of Earth fault/Short Circuit fault**

**I Practical Significance**

Earth fault and short circuit faults are critical electrical phenomena with significant practical implications for safety and system reliability. Understanding these faults are essential for preventing accidents and maintaining the integrity of electrical systems.

**II Industry/Employer Expected Outcome(s)**

Select and use different switchgears and protection schemes to maintain the reliability and stability of the power system.

**III Course Level Learning Outcome(s)**

Recognize the different types of faults occurring in power system.

**IV Laboratory Learning Outcome(s)**

LLO 1.1 Test protection system for the earth fault or short circuit fault.

**V Relevant Affective Domain related outcome(s)**

1. Follow safety electrical rules for safe practices.

**VI Relevant Theoretical Background**

The fault in the power system is defined as the defect in the power system due to which the current is distracted from the intended path. The fault creates the abnormal condition which reduces the insulation strength between the conductors. The reduction in insulation causes excessive damage to the system. The fault in the power system is mainly categorised into two types, they are

# POWER SYSTEM FAULTS

## CAUSES, TYPES & IMPACT

### UNSYMMETRICAL FAULTS

#### 1 SINGLE LINE TO GROUND FAULT

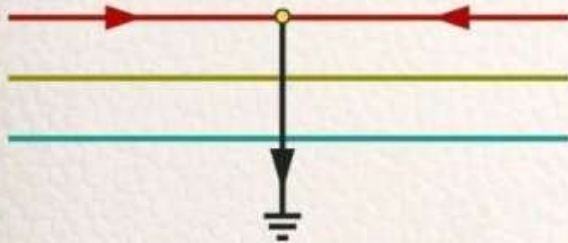

- Most common, caused by insulation breakdown or lightning strike

#### 2 LINE-TO-LINE FAULT

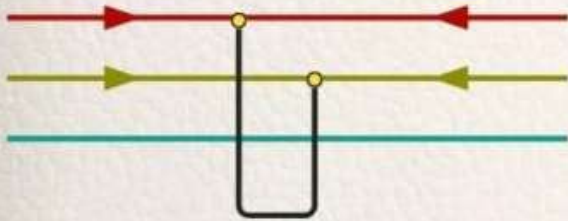

- Medium severity, caused by conductor-to-conductor contact, mechanical damage.

#### 3 DOUBLE LINE TO GROUND FAULT

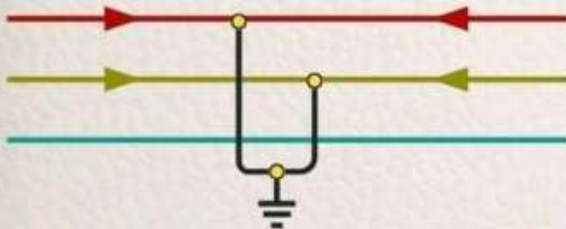

- Higher impact than line-to-line faults, caused by tree falls, mechanical failure.

### SYMMETRICAL FAULTS

#### 4 THREE PHASE FAULT

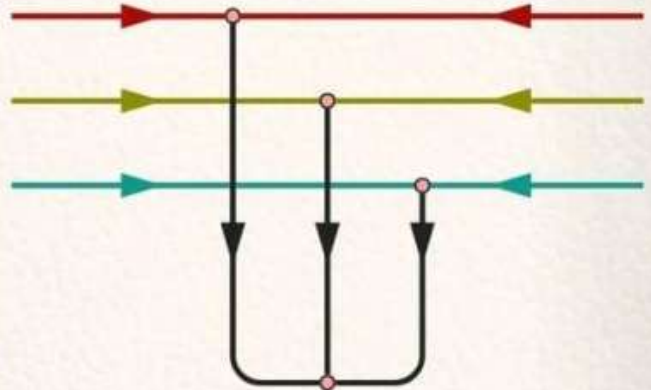

- All three phases shorted, most severe, rare but catastrophic.

#### 5 THREE PHASE TO GROUND FAULT

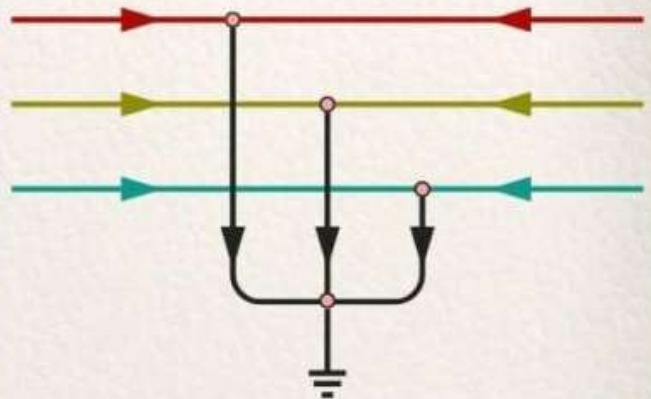

- All three phases plus ground shorted, severe & system-wide impact.

**VII Actual Circuit diagram used in laboratory with equipment Specifications**

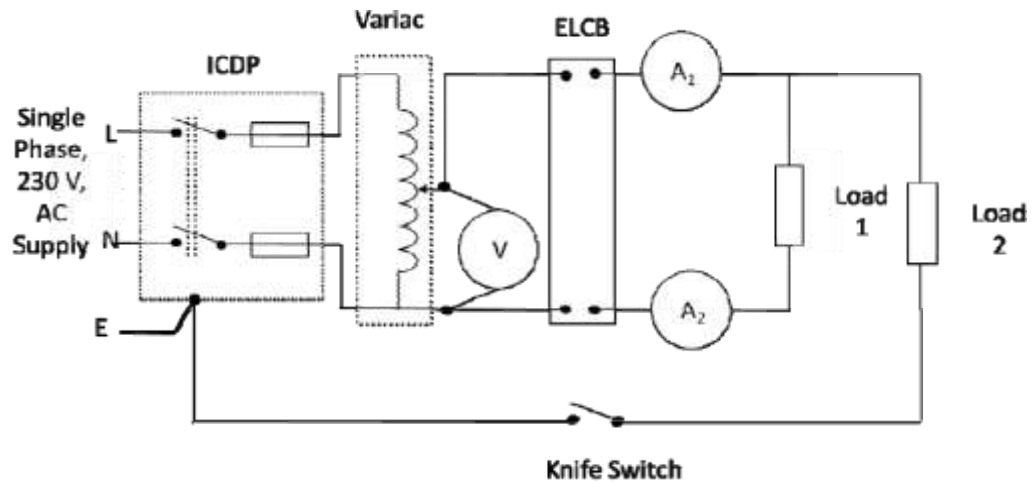

**Fig:1.1 Testing of earth fault condition**

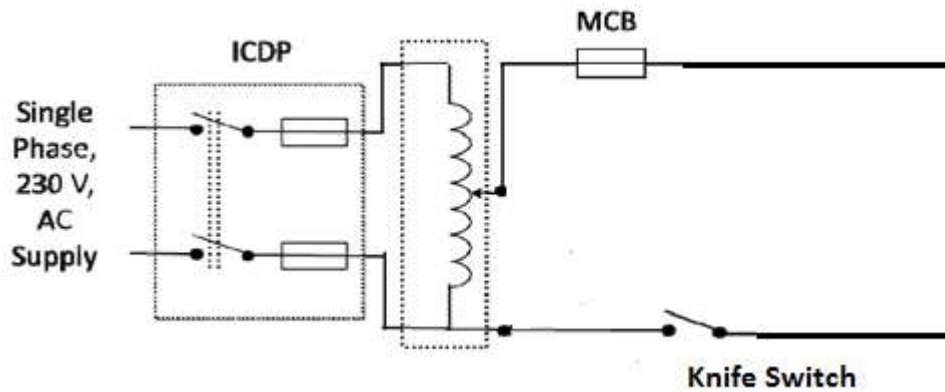

**Fig. 1.2 Testing of Short circuit condition**

**VIII Required Resources/apparatus/equipment with specification**

Sr. No	Name of Resources	Suggested specifications	Broad	Quantity	Remark
1	Autotransformer	0-270V,15A,1-2kVA		1	
2	A.C Voltmeter	Range- 0 to 300V		1	
3	A.C Ammeter	Range- 0 to 10A		2	
4	ELCB/RCCB	Single phase, 240 V, 20A		1	
5	MCB	1 Amp, Type B, 6kA, 240 V		1	

6	Resistive load / lamp load	Suitable size	2	
7	Knife Switch	Single Pole Single Throw	1	

**IX Precautions to be followed**

1. While testing ELCB proper ratings of fuses should be used in ICDP.
2. Precautions should be taken while operating knife switch.

**X Procedure****Part-I Earth fault**

1. Connect the circuit as shown in the diagram.
2. Apply rated voltage by using auto transformer.
3. Switch ON the load.
4. Measure current through live and neutral wire before closing the knife switch.
5. By operating knife switch create earth fault.
6. Measure current through live and neutral wire after closing the knife switch.
7. Note down the tripping time of RCCB.

**Part-II Short Circuit Fault**

1. Connect ICDP, MCB, and knife switch (should be open) as shown in the fig
2. Switch on the supply.
3. Close the knife switch.
4. Observe the working of MCB.

**XI Observation Table****Part-I (Earth Fault)**

Sr. No.	Before operating knife switch		After operating knife switch	
	Current through live wire	Current through neutral wire	Current through live wire	Current through neutral wire

**Part-II (Short Circuit fault)**

Sr. No.	Position of Knife Switch	Observe Operation of MCB

**XII Result(s)**

.....  
.....  
.....

**XIII Interpretation of results**

.....  
.....  
.....

**XIV Conclusion and recommendation**

.....  
.....  
.....

**XV Practical related questions** (Note:- Teacher should provide various questions related to practical-sample given)

1. What are the common causes of an earth fault and short circuit?
2. Which instruments are used to detect earth faults?
3. What safety measures should be followed while dealing with earth faults?

.....  
.....  
.....  
.....  
.....  
.....  
.....



**XVI References/Suggestions for further reading**

1. Book: Mehta V. K ; Rohit Mehta, Principles of Power System ,S.Chand and Co., New Delhi., 2016 ISBN: 978-93-5501-077-3
2. Book: Rao.Sunil S. Switchgear and Protection Khanna Publishers, New Delhi, 2015 ISBN: 978-93-87394-72-8 3
3. Book: Gupta. J. B. Switchgear and Protection S. K. Kataria and Sons, New Delhi, 2015ISBN: 978-93-5014-372-8.
4. www.cgglobal.com
5. [www.youtube.com/watch?v=HcMh7ahJxfo](http://www.youtube.com/watch?v=HcMh7ahJxfo)
6. <https://www.electrical4u.com/?s=earth+faults>

**XVII Suggested Assessment Scheme**

Performance Indicators		Weightage
<b>Process Related: 15 Marks</b>		<b>60 %</b>
1	Selection of meters and components	20%
2	Handling of the HRC fuse and load	10%
3	Reading meters accurately	10%
4	connection of circuits	10%
5	Follow safe practices	10%
<b>Product Related: 10 Marks</b>		<b>40%</b>
6	Writing result	10%
7	Interpretation of result	05%
8	Conclusions	05%
9	Practical related questions	15%
10	Submitting the journal in time	05%
<b>Total (25 Marks)</b>		<b>100 %</b>

Marks Obtained			Dated signature of Teacher
Process Related (15)	Product Related (10)	Total (25)	

## Practical No. 2: Testing of HRC Fuse.

### I Practical Significance

The primary drawback of low and uncertain breaking capacity of semi-enclosed re-wireable fuse is overcome in HRC cartridge fuse. HRC fuse has high short circuit current and gives reliable and very accurate operation. They do not deteriorate with age and also give consistent performance.

### II Industry/Employer Expected Outcome(s)

Select and use different switchgears and protection schemes to maintain the reliability and stability of the power system.

### III Course Level Learning Outcome(s)

Select the suitable switchgears for different applications.

### IV Laboratory Learning Outcome(s)

LLO 2.1 Test the performance of HRC fuse.

LLO 2.2 Validate the performance of HRC fuse by drawing the inverse time current characteristics.

### V Relevant Affective Domain related outcome(s)

1. Follow safety electrical rules for safe practices.

### VI Relevant Theoretical Background

- A fuse is a short piece of metal inserted in the circuit which melts when excessive current flows through it and thus breaks the circuit.
- Fusing action - Heat produced by overcurrent causes current carrying fuse element to melt open and disconnecting load from source voltage.
- Classification of fuse- In general fuse may be classified into:
  - Low voltage fuse
  - High voltage fuse
- Characteristics of fuses-

Fuse exhibits inverse time characteristics i.e. Increase in current through the fuse causes reduction in pre-arcing time.

HRC fuse consists of a heat resisting ceramic body having metal end caps to which welded silver current carrying element. It is completely packed with a filling powder. When a fault occurs, the current increases and the fuse element melts. The heat produced vaporizes the melted silver element. The chemical reaction results in the formation of high resistance substance which quenches the arc.



**HRC Fuses**

**VII Actual Circuit diagram used in laboratory with equipment Specifications**

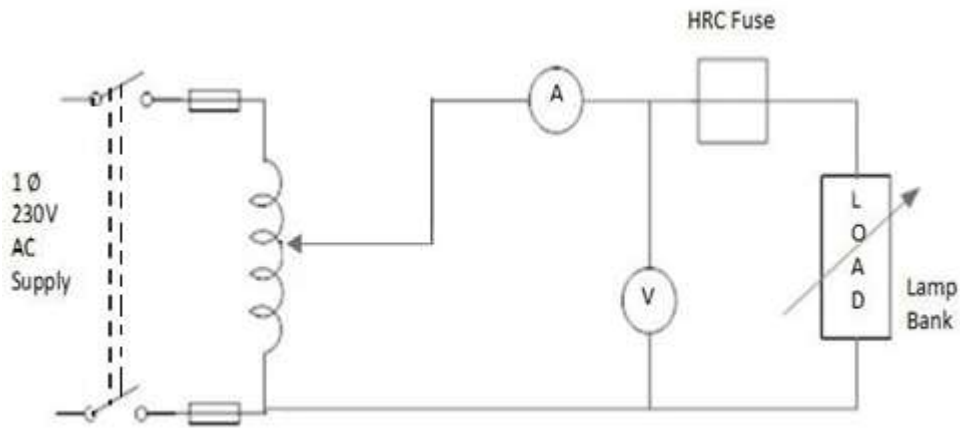

**Fig. 2.1 Circuit diagram to test HRC fuse**

**VIII Required Resources/apparatus/equipment with specification**

Sr. No	Name of Resources	Suggested specifications	Broad	Quantity	Remark
1	Autotransformer	0-270V,15A,1-2kVA		1	
2	A.C Voltmeter	Range- 0 to 300V		1	
3	A.C Ammeter	Range- 0 to 10A		1	
4	HRC fuse	Range- 0 to 6A		As per requirement	
5	Lamp bank	Range- 10 to 20 A		1	

**IX Precautions to be followed**

1. There should not be any loose connection.
2. Ensure that proper rating of HRC fuse is selected for the given circuit.
3. Ensure that supply is OFF while replacing the fuse.
4. Follow electrical safety rules.

**X Procedure**

1. Connections are made as per the circuit diagram.
2. Switch on the supply and adjust rated load current.
3. Gradually increase the load current in steps of 10% of rated and note down the time of operation for each current above rated till fuse blows.
4. Plot the graph between current and time of operation.

**XI Observation Table**

Sr. No.	Load current in Amps.	Current through fuse Element in Amps.	Time of operation in seconds
1			
2			
3			
4			

**XII Result(s)**

.....  
.....  
.....

**XIII Interpretation of results**

.....  
.....  
.....





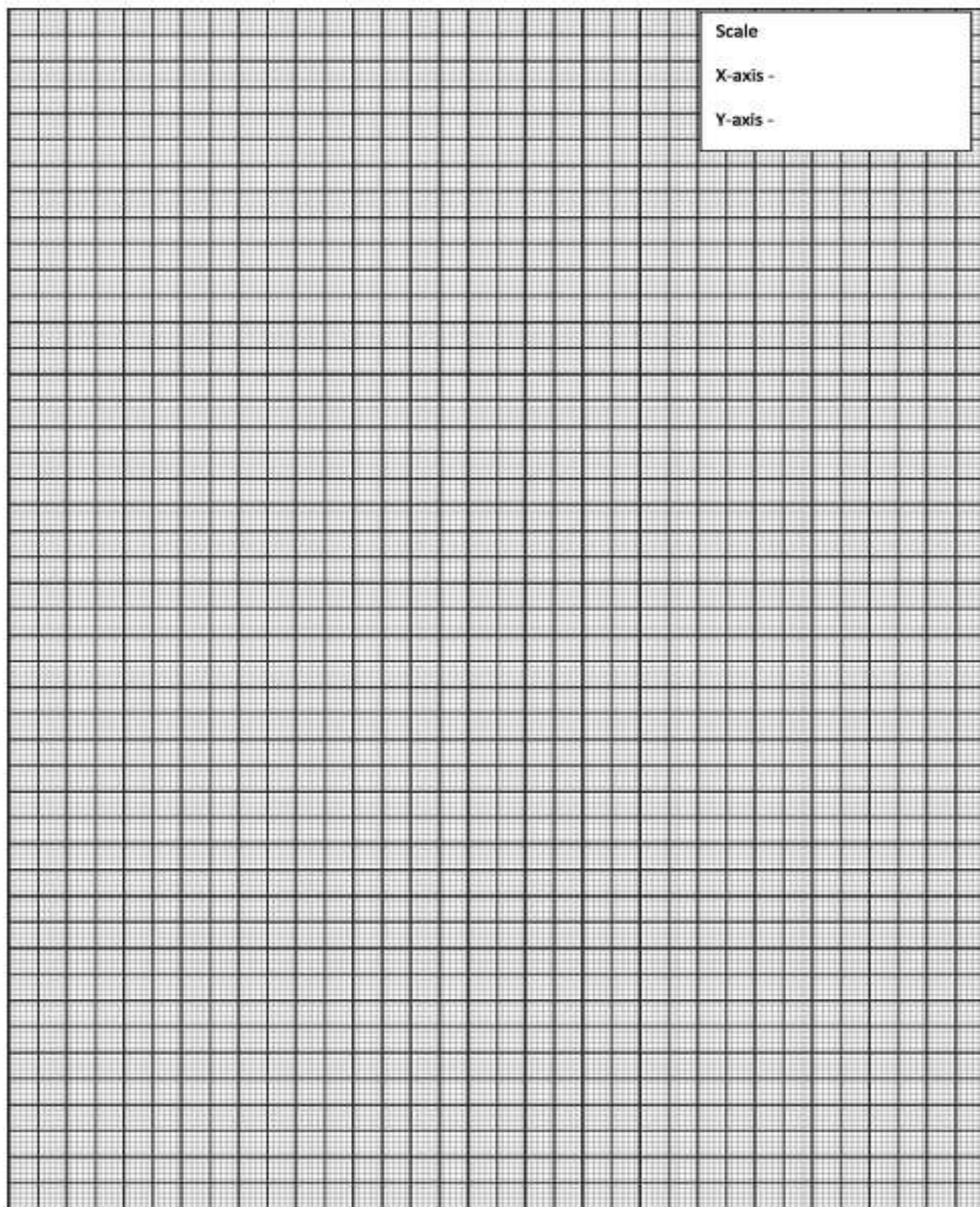

**XVI References/Suggestions for further reading**

1. Book: Mehta V. K ; Rohit Mehta, Principles of Power System ,S.Chand and Co., New Delhi., 2016 ISBN: 978-93-5501-077-3
2. Book: Rao.Sunil S. Switchgear and Protection Khanna Publishers, New Delhi, 2015 ISBN: 978-93-87394-72-8 3
3. Book: Gupta. J. B. Switchgear and Protection S. K. Kataria and Sons, New Delhi, 2015 ISBN: 978-93-5014-372-8.
4. [www.electrical4u.com](http://www.electrical4u.com)
5. <https://www.electricaltechnology.org/2014/12/hrc-fuse-high-rupturing-capacity-fuse-types.html>

**XVII Suggested Assessment Scheme**

Performance Indicators		Weightage
<b>Process Related: 15 Marks</b>		<b>60 %</b>
1	Selection of meters and components	20%
2	Handling of the HRC fuse and load	10%
3	Reading meters accurately	10%
4	connection of circuits	10%
5	Follow safe practices	10%
<b>Product Related: 10 Marks</b>		<b>40%</b>
6	Writing result	10%
7	Interpretation of result	05%
8	Conclusions	05%
9	Practical related questions	15%
10	Submitting the journal in time	05%
<b>Total (25 Marks)</b>		<b>100 %</b>

Marks Obtained			Dated signature of Teacher
Process Related (15)	Product Related (10)	Total (25)	

### Practical No. 3 : Testing of Miniature Circuit Breaker

#### I Practical Significance

MCB is the most important component of a power distribution system. It provides safety and proper operation of the system. It is essential to ensure its working by testing the same.

#### II Industry/Employer Expected Outcome(s)

Select and use different switchgears and protection schemes to maintain the reliability and stability of the power system.

#### III Course Level Learning Outcome(s)

Select the suitable switchgears for different applications.

#### IV Laboratory Learning Outcome(s)

LLO 3.1 Test the performance of MCB.

LLO 3.2 Validate the performance of MCB by drawing the inverse time current characteristics.

#### V Relevant Affective Domain related outcome(s)

1. Follow safety electrical rules for safe practices.

#### VI Relevant Theoretical Background

MCB switches "OFF" the electrical circuit during overload and short circuits. It is compact in size and has current ratings from 0.5A to 100A. MCBs are classified according to current range at which they trip instantly mainly three types of MCBs are available. They are

1. Type B- Trips at 3 to 5 times rated current.
2. Type C- Trips at 5 to 10 times rated current.
3. Type D- Trips at 10 to 20 times rated current



<b>B</b>	<b>Type</b>
<b>C</b>	<b>Type</b>
<b>D</b>	<b>Type</b>
<b>K</b>	<b>Type</b>
<b>Z</b>	<b>Type</b>

## VII Actual Circuit diagram used in laboratory with equipment Specifications

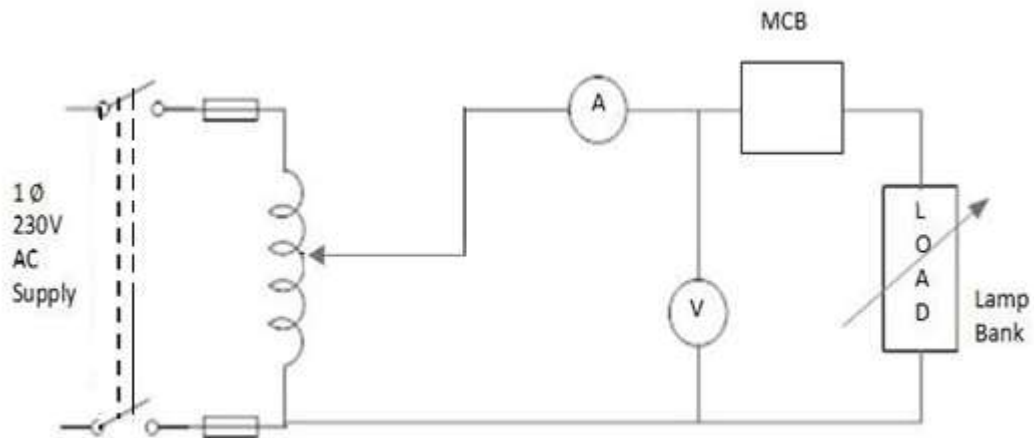

**Fig:3.1 Circuit diagram to test MCB**

## VIII Required Resources/apparatus/equipment with specification

Sr. No	Name of Resources	Suggested specifications	Broad	Quantity	Remark
1	Autotransformer	0-270V, 15A, 1-2kVA		1	
2	A.C Voltmeter	Range- 0 to 300V		1	
3	A.C Ammeter	Range- 0 to 10A		1	
4	Single pole MCB	1 A, Type B, 6kA, 240V		1	
5	Lamp bank	Range- 10 to 20 A		1	

## IX Precautions to be followed

1. While testing MCB proper rating of fuses should be used in ICDP.
2. Ensure that proper rating of MCB is selected for the given circuit.
3. Follow electrical safety rules.

## X Procedure

1. Connect ICDP, Variac, MCB, ammeter and load as per the circuit diagram shown.
2. Switch on the supply.
3. Gradually increase the voltage up to voltage rating of MCB.

4. Increase the load up to 3 times current rating of MCB.
5. Record the tripping time of MCB and ammeter reading in the observation table.
6. Switch on MCB.
7. Increase the load up to 4 to 5 times of current rating of MCB
8. Record the tripping time of MCB and ammeter reading in the observation table.
9. Plot the graph between current and tripping time of MCB.

**XI Observation Table**

Sr. No.	Current through circuit.	Tripping time of MCB
1		
2		
3		
4		

**XII Result(s)**

.....  
.....  
.....

**XIII Interpretation of results**

.....  
.....  
.....

**XIV Conclusion and recommendation**

.....  
.....  
.....

**XV Practical related questions** (Note:- Teacher should provide various questions related to practical-sample given)

1. MCB selection needs to be done carefully; justify.
2. State the specification of MCB.
3. Explain the significance of the kA rating of MCB?
4. State the method to select rating of MCB used in residential installation.





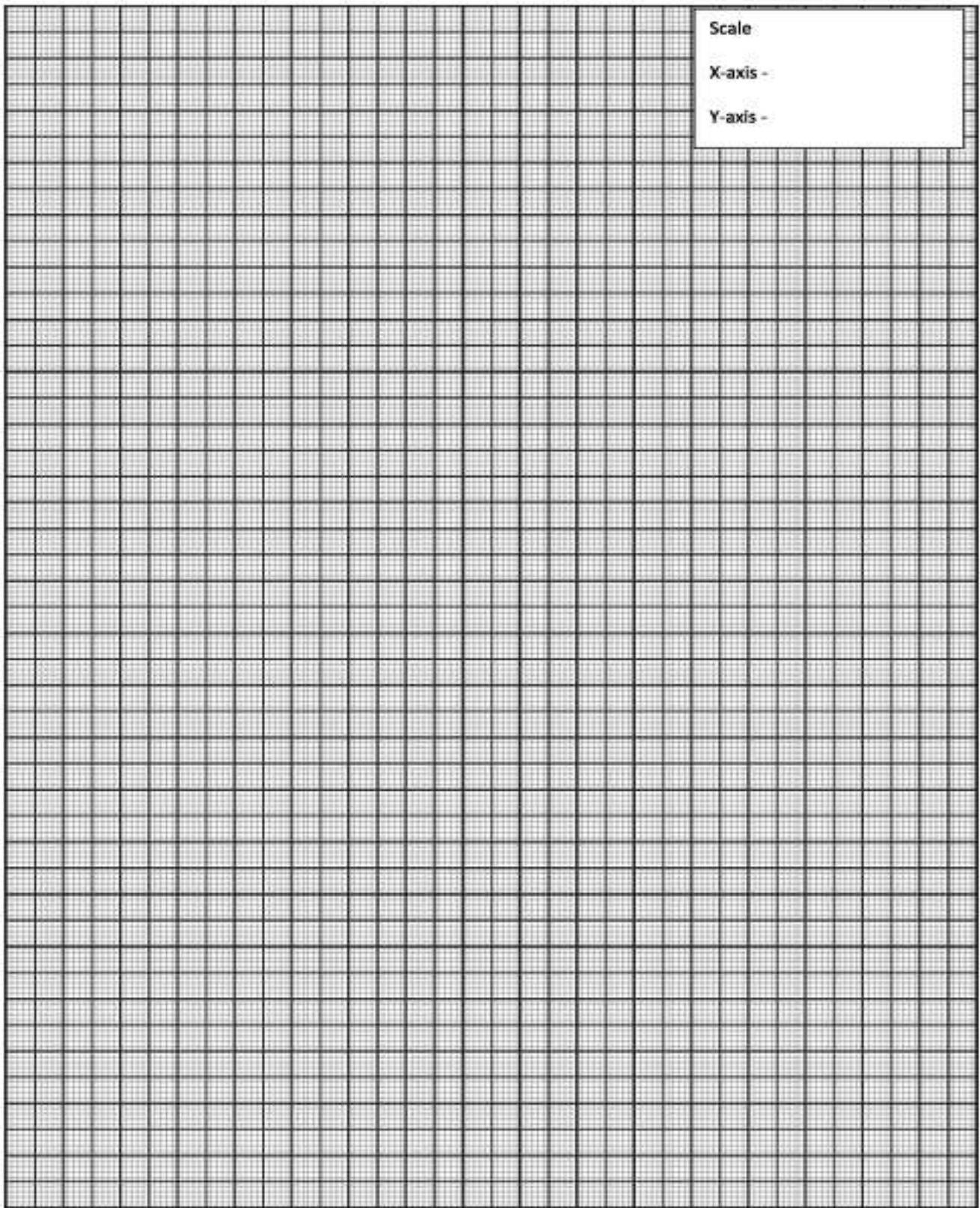

**XVI References/Suggestions for further reading**

1. Book: Mehta V. K ; Rohit Mehta, Principles of Power System ,S.Chand and Co., New Delhi., 2016 ISBN: 978-93-5501-077-3
2. Book: Rao.Sunil S. Switchgear and Protection Khanna Publishers, New Delhi, 2015 ISBN: 978-93-87394-72-8 3
3. Book: Gupta. J. B. Switchgear and Protection S. K. Kataria and Sons, New Delhi, 2015ISBN: 978-93-5014-372-8.
4. <https://new.abb.com/low-voltage/products/system-pro-m/miniature-circuit-breakers>
5. [https://www.electricaltechnology.org/2016/02/mcb-miniature-circuit-breaker-types-construction-working-uses.html#google\\_vignette](https://www.electricaltechnology.org/2016/02/mcb-miniature-circuit-breaker-types-construction-working-uses.html#google_vignette)

**XVII Suggested Assessment Scheme**

Performance Indicators		Weightage
<b>Process Related: 15 Marks</b>		<b>60 %</b>
1	Selection of meters and components	20%
2	Handling of the MCB and Load	10%
3	Reading meters accurately	10%
4	connection of circuits	10%
5	Follow safe practices	10%
<b>Product Related: 10 Marks</b>		<b>40%</b>
6	Writing result	10%
7	Interpretation of result	05%
8	Conclusions	05%
9	Practical related questions	15%
10	Submitting the journal in time	05%
<b>Total (25 Marks)</b>		<b>100 %</b>

Marks Obtained			Dated signature of Teacher
Process Related (15)	Product Related (10)	Total (25)	

### **Practical No. 4 : Characteristics of Induction type overcurrent relay**

#### **I Practical Significance**

Over current relays are frequently used in power network systems because in most of the faulty conditions current generally increases beyond its design limits. Over current relay provide protection against excessive current caused by short circuit, ground faults to important power system equipment's including power transformers, generators, transmission lines, motors, bus bars etc. They are employed as primary protection as well as backup protection

#### **II Industry/Employer Expected Outcome(s)**

Select and use different switchgears and protection schemes to maintain the reliability and stability of the power system.

#### **III Course Level Learning Outcome(s)**

Test the performance of different protective relays.

#### **IV Laboratory Learning Outcome(s)**

LLO 4.1 Test of Induction type overcurrent relay by performing load test.

#### **V Relevant Affective Domain related outcome(s)**

1. Follow safety electrical rules for safe practices.

#### **VI Relevant Theoretical Background**

- An over current relay is a protective relay which operates when the load current exceeds a preset value called pick up value.
- Depending upon time of operation there are various types of over current relays.
  - Instantaneous over current relay: The contacts of the relay are closed instantly when current inside the relay rises beyond the operational value. It has low operating time.
  - Inverse time over current relay: The relay operates only when the magnitude of their operating current is inversely proportional to the magnitude of the energize quantities.
  - Inverse Definite Minimum Time over current relay (IDMT) : This relay is used for the protection of the distribution line. The characteristics with definite minimum time and inverse type is called as inverse definite minimum time (IDMT) characteristics.
  - Very inverse time over current relay: It is used in the feeder and on long transmission line.
  - Extremely inverse time overcurrent relay: This is used for protecting the cable, transformer etc. The relay provides faster operation even under the fault current.

**VII Actual Circuit diagram used in laboratory with equipment Specifications**

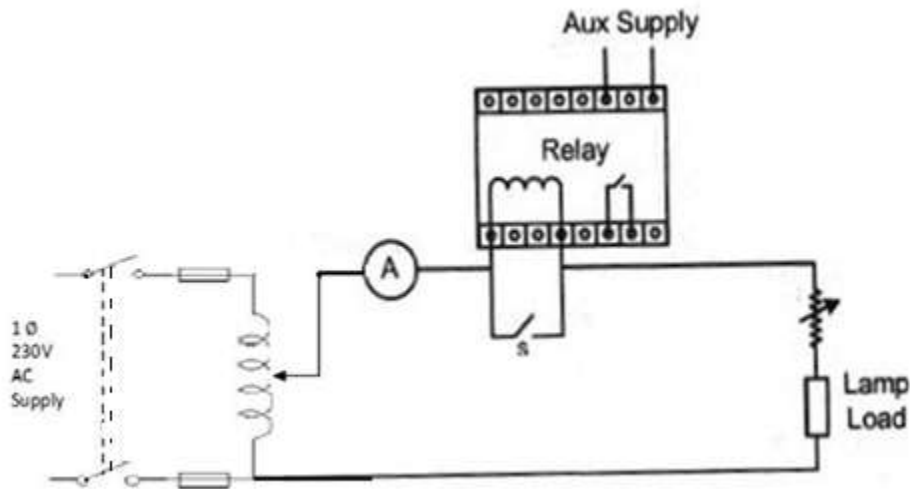

**Fig :4.1 Circuit diagram to test Induction type overcurrent relay by performing load test**

**VIII Required Resources/apparatus/equipment with specification**

Sr. No	Name of Resources	Suggested specifications	Broad	Quantity	Remark
1	Autotransformer	0-270V,15A,1-2kVA		1	
2	Over current relay	6 Amp or other suitable		1	
3	Lamp bank	Suitable rating		1	
4	A.C Ammeter	0 to 10 Amp.		1	
5	Single pole switch	0 to 5 Amp.		1	
6	Rheostat	Suitable rating		1	

**IX Precautions to be followed**

1. Make sure that the main switch is in OFF position before connection.
2. Wire used for circuit connection has proper size.
3. Follow safety practices.

**X Procedure**

1. Make the connection as per circuit diagram shown in figure.
2. Adjust the plug setting to ... %.
3. Keep the TMS setting at maximum position (1 sec.)
4. Keep the switch 'S' closed and slowly increase load current up to... A.
5. Open the switch 'S' and note the time of operation of the relay.
6. Repeat the procedure for various current values and time multiplier setting values.
7. Switch OFF the main supply.
8. Repeat the procedure with time setting multiplier adjusted to 0.1 and plot the graph as per the previous step.

**Note:** The current plug setting range used from 50% to 200% in steps of 25% for phase to phase fault and 10% to 70% in steps of 10% for earth fault.

**XI Observation Table**

Time multiplier setting (TMS): .....

Sr. No.	% tap used	Current through relay coil (A)	Time of operation (sec.)
1			
2			
3			
4			
5			
6			

Time multiplier setting (TMS): .....

Sr. No.	% tap used	Current through relay coil (A)	Time of operation (sec.)
1			
2			
3			
4			
5			
6			





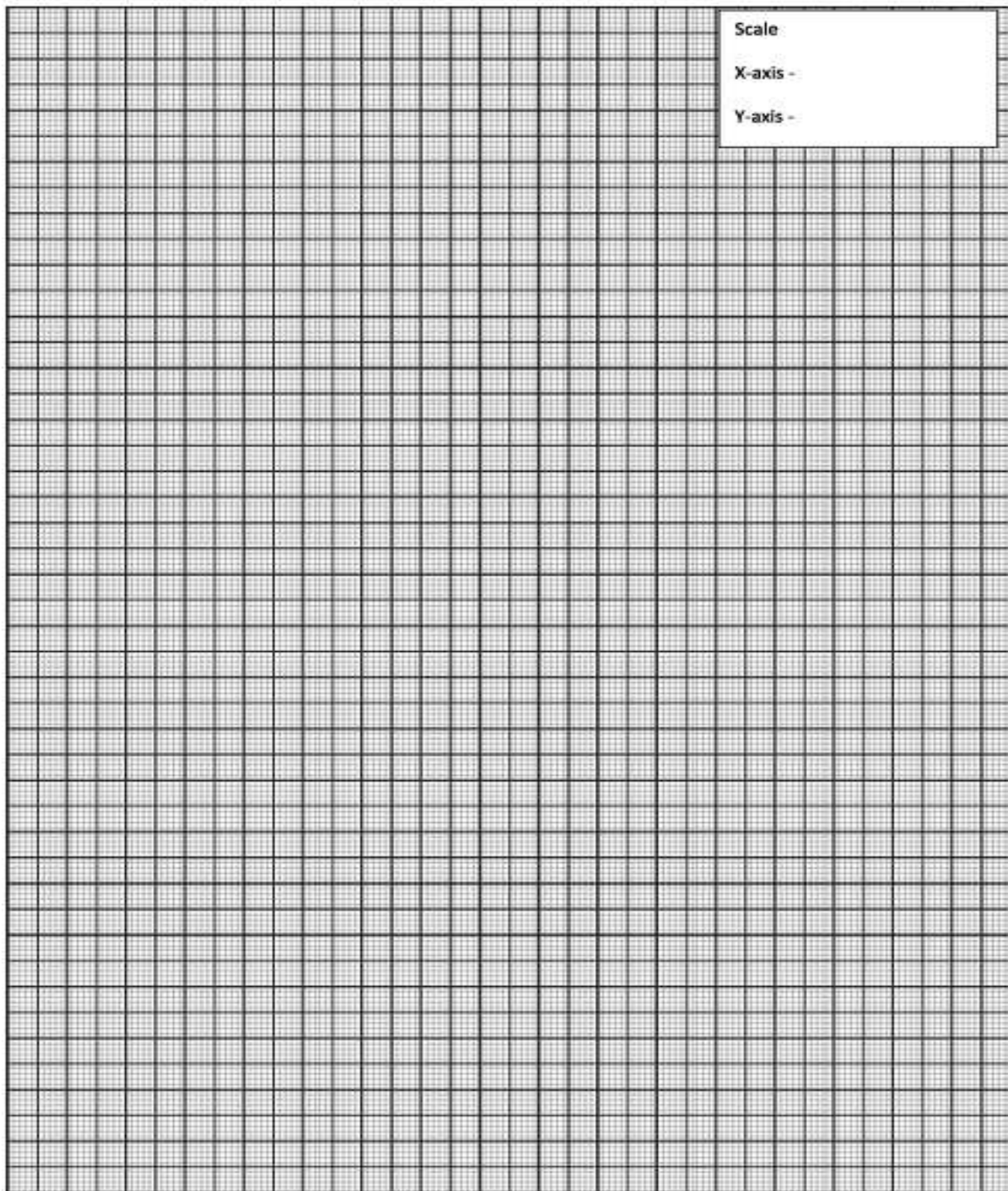

**XVI References/Suggestions for further reading**

1. Book: Rao.Sunil S. Switchgear and Protection Khanna Publishers, New Delhi, 2015 ISBN: 978-93-87394-72-8 3
2. Book: Gupta. J. B. Switchgear and Protection S. K. Kataria and Sons, New Delhi, 2015 ISBN: 978-93-5014-372-8.
3. <https://www.electrical4u.com/over-current-relay-working-principle-types/>
4. [www.electricaltechnology.org](http://www.electricaltechnology.org)

**XVII Suggested Assessment Scheme**

<b>Performance Indicators</b>		<b>Weightage</b>
<b>Process Related: 15 Marks</b>		<b>60 %</b>
1	Selection of meters and components	20%
2	Handling of the relay and load	10%
3	Reading meters accurately	10%
4	connection of circuits	10%
5	Follow safe practices	10%
<b>Product Related: 10 Marks</b>		<b>40%</b>
6	Writing result	10%
7	Interpretation of result	05%
8	Conclusions	05%
9	Practical related questions	15%
10	Submitting the journal in time	05%
<b>Total (25 Marks)</b>		<b>100 %</b>

<b>Marks Obtained</b>			<b>Dated signature of Teacher</b>
<b>Process Related (15)</b>	<b>Product Related (10)</b>	<b>Total (25)</b>	

**Practical No. 5 : Plug Setting and Time setting Multiplier of Induction type relay.**

**I Practical Significance**

Over current relays are frequently used in power network systems because in most of the faulty conditions current generally increases beyond its design limits. Over current relay provide protection against excessive current caused by short circuit, ground faults to important power system equipments including power transformers, generators, transmission lines, motors, bus bars etc. They are employed as primary protection as well as backup protection.

**II Industry/Employer Expected Outcome(s)**

Select and use different switchgears and protection schemes to maintain the reliability and stability of the power system.

**III Course Level Learning Outcome(s)**

Test the performance of different protective relays.

**IV Laboratory Learning Outcome(s)**

LLO 5.1 Carry out plug and time setting (with PSM, TSM) of Induction type electromagnetic relay.

**V Relevant Affective Domain related outcome(s)**

1. Follow safety electrical rules for safe practices.

**VI Relevant Theoretical Background**

- A protective relay senses the abnormal electrical conditions and sends signal to circuit breaker which disconnects supply to the faulty of the circuit.
- The electromagnetic relay operates on the principle of a split-phase induction motor.
- It has long operating time at low multiples of current setting and a shorter operating time at high multiples of current setting.
- Plug setting (PS) : It is given at low multiples of current setting and a shorter operating time at high multiples of current setting.
- Plug setting multiplier (P.S.M): It is the ratio of fault current in the relay coil to pick up current.
- Time multiplier setting (T.M.S.): TMS for an inverse time relay is the ratio of the required time of operation T to the obtained from the relay characteristics at TMS=1.0 and PSM equivalent to maximum fault current.

**Pick up current=Rated secondary current of CT x Current setting**

$$\text{PSM} = \frac{\text{Fault current in the relay}}{\text{Pick up current}}$$

## VII Actual Circuit diagram used in laboratory with equipment Specifications

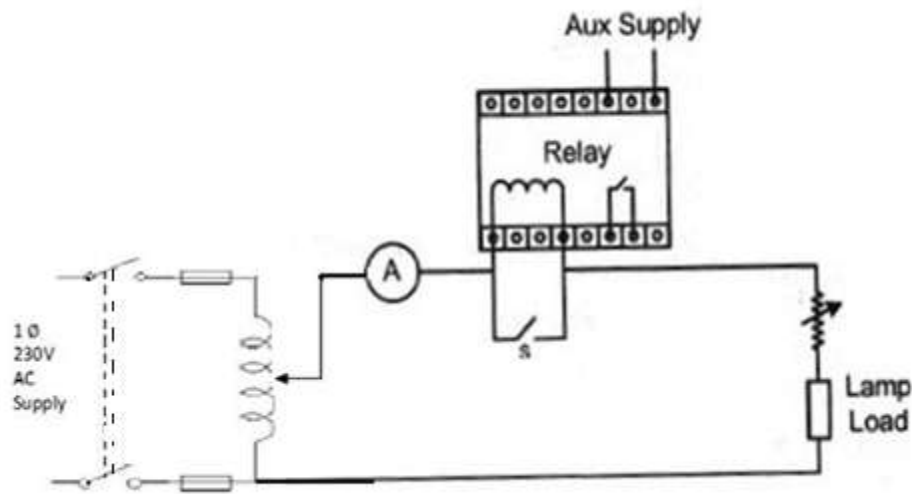

Fig :5.1 Circuit diagram to test Induction type overcurrent

## VIII Required Resources/apparatus/equipment with specification

Sr. No	Name of Resources	Suggested specifications	Broad	Quantity	Remark
1	Autotransformer	0-270V, 15A, 1-2kVA		1	
2	Over current relay	6 Amp or other suitable		1	
3	Lamp bank	Suitable rating		1	
4	A.C Ammeter	0 to 10 Amp.		1	
5	Single pole switch	0 to 5 Amp.		1	
6	Rheostat	Suitable rating		1	

## IX Precautions to be followed

1. Make sure that the main switch is in OFF position before connection.
2. Wire used for circuit connection has proper size.
3. Follow safety practices.

## X Procedure

1. Make the connection as per circuit diagram shown in figure.
2. Adjust the plug setting to ... %.

3. Keep the TMS setting at maximum position (1 sec.)
4. Keep the switch 'S' closed and slowly increase load current up to... A..
5. Open the switch 'S' and note the time of operation of the relay.
6. Repeat the procedure for various current values and time multiplier setting values.
7. Switch OFF the main supply.
8. Repeat the procedure with time setting multiplier adjusted to 0.1 .

**Note:** The current plug setting range used from 50% to 200% in steps of 25% for phase to phase fault and 10% to 70% in steps of 10% for earth fault.

**XI Observation Table**

**Time multiplier setting (TMS): .....**

Sr. No.	% tap used	Current through relay coil (A)	Time of operation (sec.)	P.S.M. Value
1				
2				
3				
4				
5				
6				

**Time multiplier setting (TMS): .....**

Sr. No.	% tap used	Current through relay coil (A)	Time of operation (sec.)	P.S.M. Value
1				
2				
3				
4				
5				
6				

$$\text{PSM Value} = \frac{\text{Current through relay coil}}{\text{Nominal current of relay} \times \frac{\% \text{ tap used}}{100}}$$

**Or**

$$\text{PSM Value} = \frac{\text{Fault current in the relay}}{\text{pick up value}}$$

**XII Result(s)**

.....

.....

.....

**XIII Interpretation of results**

.....

.....

.....

**XIV Conclusion and recommendation**

.....

.....

.....

**XV Practical related questions** (Note:- Teacher should provide various questions related to practical- sample given)

1. The current setting of an overcurrent relay is 5A current setting is at 200%.T.S.M.=0.4, CT ration=400/5,Fault current=4000 A. Determine the operating time of the relay using the following table of operating time at various PSM at TMS=1

PSM	2	4	8	20
Relay time in seconds	10	5	3	2.4

2. What changes in time occurs if the current setting is changed from lower taps to higher taps?

.....

.....

.....

.....

.....

.....

.....

.....

.....

.....

.....



**XVI References/Suggestions for further reading**

1. Book: Mehta V. K ; Rohit Mehta, Principles of Power System ,S.Chand and Co., New Delhi., 2016 ISBN: 978-93-5501-077-3
2. Book: Rao.Sunil S. Switchgear and Protection Khanna Publishers, New Delhi, 2015 ISBN: 978-93-87394-72-8 3
3. Book: Gupta. J. B. Switchgear and Protection S. K. Kataria and Sons, New Delhi, 2015ISBN: 978-93-5014-372-8.
4. <https://www.electrical4u.com/over-current-relay-working-principle-types/>
5. [www.electricaltechnology.org](http://www.electricaltechnology.org)

**XVII Suggested Assessment Scheme**

Performance Indicators		Weightage
<b>Process Related: 15 Marks</b>		<b>60 %</b>
1	Selection of meters and components	20%
2	Handling of the relay and load	10%
3	Reading meters accurately	10%
4	connection of circuits	10%
5	Follow safe practices	10%
<b>Product Related: 10 Marks</b>		<b>40%</b>
6	Writing result	10%
7	Interpretation of result	05%
8	Conclusions	05%
9	Practical related questions	15%
10	Submitting the journal in time	05%
<b>Total (25 Marks)</b>		<b>100 %</b>

Marks Obtained			Dated signature of Teacher
Process Related (15)	Product Related (10)	Total (25)	

**Practical No. 6 : Demonstrate /Simulate differential protection scheme for different types of faults on Alternator.**

**I Practical Significance**

Alternator is the major equipment of Electrical Power System. It is desirable and necessary to protect alternator from a variety of faults. The differential system provides automatic protection against both earth and phase to phase faults. This method of protection is most commonly employed due to its greater sensitivity and reliability.

**II Industry/Employer Expected Outcome(s)**

Select and use different switchgears and protection schemes to maintain the reliability and stability of the power system.

**III Course Level Learning Outcome(s)**

Use suitable protection schemes for alternators, motors ,transformers, busbars and transmission lines.

**IV Laboratory Learning Outcome(s)**

LLO 6.1 Use Differential protection for protecting the Alternator.

**V Relevant Affective Domain related outcome(s)**

1. Follow safety electrical rules for safe practices.

**VI Relevant Theoretical Background**

The most common system used for the protection of stator winding faults employs circulating-Current principle. In this scheme of Differential Protection of Alternators, currents at the two ends of the protected section are compared. Under normal operating conditions, these currents are equal but may become unequal on the occurrence of a fault in the protected section. The difference of the currents under fault conditions is arranged to pass through the operating coil of the relay. The relay then closes its contacts to isolate protected section from the system. This form of protection is also known as **Merz-Price Circulating Current Scheme**.

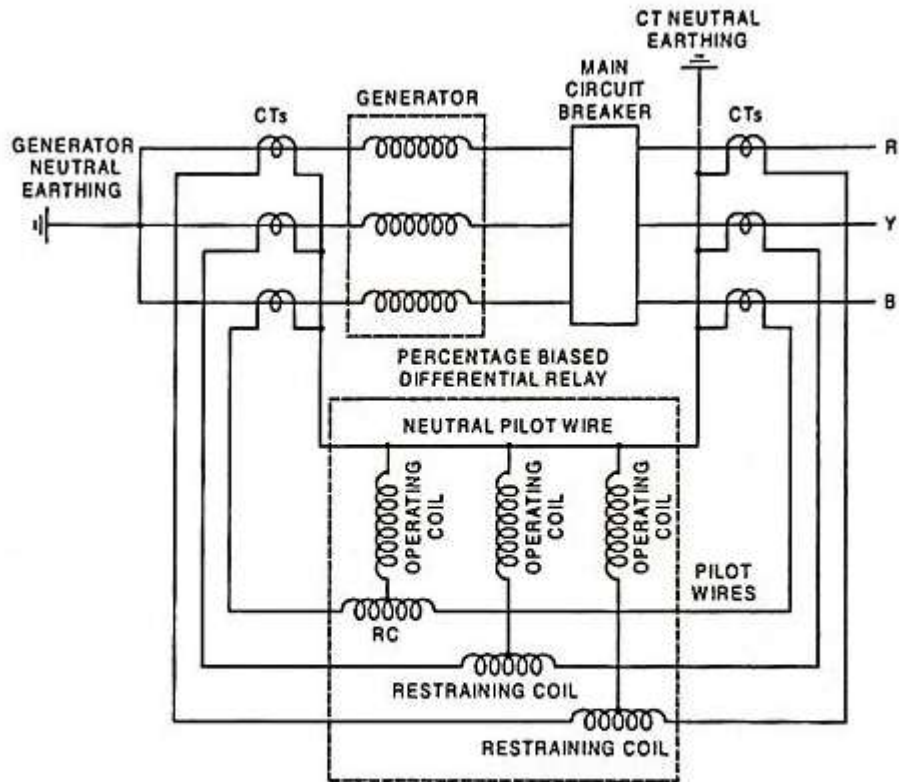

**Schematic Diagram For Percentage Differential Relay Protection of a Star-Connected Generator**

**VII Actual Circuit diagram used in laboratory with equipment Specifications**

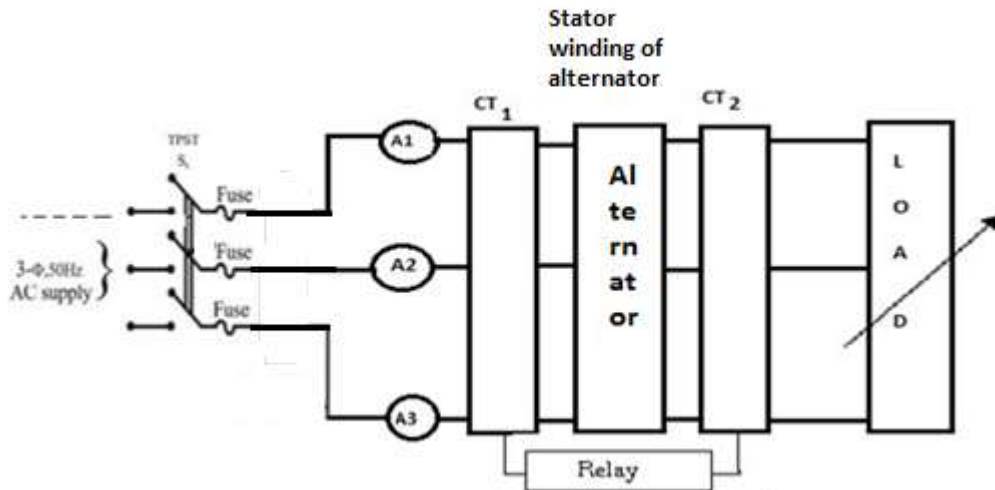

**Fig:6.1. Simulation Diagram for alternator protection**

**VIII Required Resources/apparatus/equipment with specification**

Sr. No	Name of Resources	Suggested specifications	Broad standard	Quantity	Remark
1	Simulation kit for Alternator differential protection	Available Rating	standard	1	
2	Alternator set	Suitable Rating		1	
3	CTs	Suitable Rating		6	
4	Relays	Suitable Rating		3	

**IX Precautions to be followed**

1. CTs of proper ratio should be used so that currents under normal condition are equal at both end of alternator stator windings.
2. Ensure that no load current does not trip the breaker under normal condition.

**X Procedure**

1. Connect the circuit as per circuit diagram.
2. Keep the fault switch open (no fault condition).
3. Start the alternator with no load and observe relay operation.
4. Gradually apply balanced load and observe readings of voltage and current in all three phases.
5. Simulate short circuit between any two phases at alternator terminals.
6. Observe operation of relay and note down the values of current at which circuit breaker trips.
7. Reset the system and similarly simulate an earth fault in any one of winding and note down the current at which circuit breaker trips.

**XI Observation Table**

Sr. No.	Type of fault	Normal Current	Fault current	Relay Status
1	Phase to phase fault			
2	Earth fault			





**XVI References/Suggestions for further reading**

1. Book: Mehta V. K ; Rohit Mehta, Principles of Power System ,S.Chand and Co., New Delhi., 2016 ISBN: 978-93-5501-077-3
2. Book: Rao.Sunil S. Switchgear and Protection Khanna Publishers, New Delhi, 2015 ISBN: 978-93-87394-72-8 3
3. Book: Gupta. J. B. Switchgear and Protection S. K. Kataria and Sons, New Delhi, 2015 ISBN: 978-93-5014-372-8.
4. <https://www.electrical4u.com/differential-protection-of-generator-or-alternator/>
5. <https://www.eeeguide.com/differential-protection-of-alternators/>

**XVII Suggested Assessment Scheme**

Performance Indicators		Weightage
<b>Process Related: 15 Marks</b>		<b>60 %</b>
1	Selection of meters and components	20%
2	Handling of the relay and load	10%
3	Reading meters accurately	10%
4	connection of circuits	10%
5	Follow safe practices	10%
<b>Product Related: 10 Marks</b>		<b>40%</b>
6	Writing result	10%
7	Interpretation of result	05%
8	Conclusions	05%
9	Practical related questions	15%
10	Submitting the journal in time	05%
<b>Total (25 Marks)</b>		<b>100 %</b>

Marks Obtained			Dated signature of Teacher
Process Related (15)	Product Related (10)	Total (25)	

**Practical No. 7 : Demonstrate /Simulate differential protection scheme for different types of faults on Transformer.**

**I Practical Significance**

Transformer is the major component of Electrical Power System. It is desirable and necessary to protect transformer from a variety of faults. The differential system provides automatic protection against both earth and phase to phase faults. This method of protection is most commonly employed due to its greater sensitivity and reliability.

**II Industry/Employer Expected Outcome(s)**

Select and use different switchgears and protection schemes to maintain the reliability and stability of the power system.

**III Course Level Learning Outcome(s)**

Use suitable protection schemes for alternators, motors , transformers, busbars and transmission lines.

**IV Laboratory Learning Outcome(s)**

LLO 7.1 Use Differential protection for protecting the Transformer.

**V Relevant Affective Domain related outcome(s)**

1. Follow safety electrical rules for safe practices.

**VI Relevant Theoretical Background**

Merz-price circulating current principle is commonly used for the protection of power transformers against earth and phase faults. In this scheme of protection, currents at the two sides of the transformer are compared. Under normal conditions, they are made equal by overcoming all difficulties and taking proper remedial measures. But on the occurrence of a fault in the protected section, currents may become unequal and difference of the currents is arranged to pass through the operating coil of the relay. The relay then closes its contacts to isolate the protected section from the healthy part of the system.

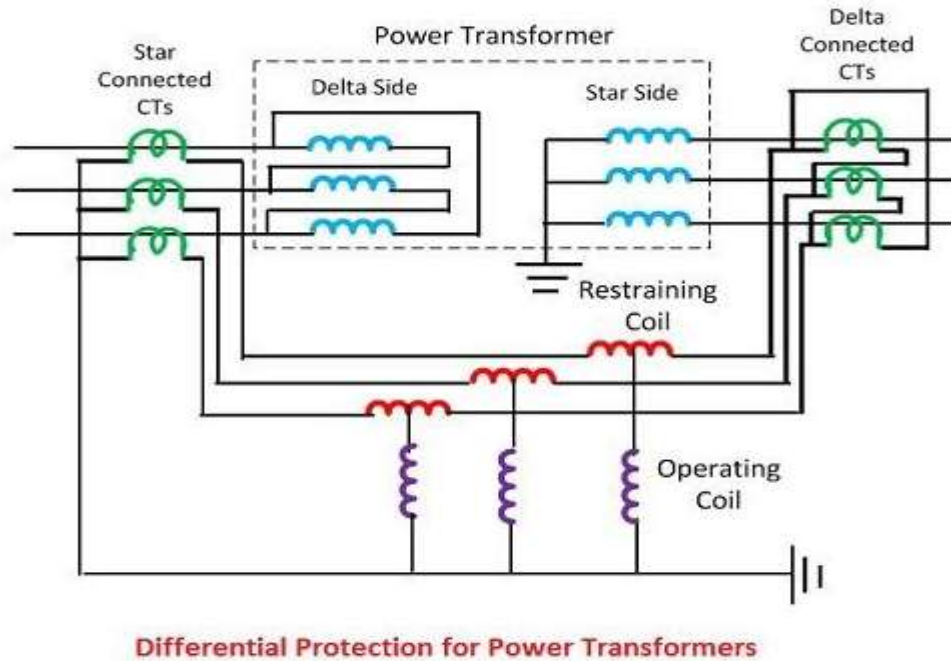

**VII Actual Circuit diagram used in laboratory with equipment Specifications**

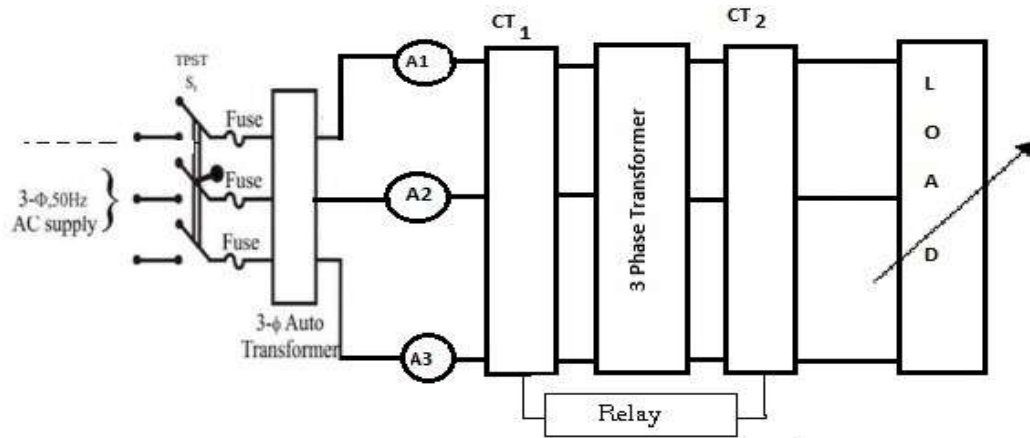

**Fig:7.1. Simulation diagram for transformer protection**

**VIII Required Resources/apparatus/equipment with specification**

<b>Sr. No</b>	<b>Name of Resources</b>	<b>Suggested specifications</b>	<b>Broad standard</b>	<b>Quantity</b>	<b>Remark</b>
1	Simulation kit for Transformer differential protection	Available Rating	standard	1	
2	3-Phase Transformer	1kVA,415V/230V,Star-Delta,50 Hz		1	
3	CTs	Suitable Rating		6	
4	Relays	Suitable Rating		3	
5	Three phase autotransformer	Suitable Rating		1	
6	Three Phase load	Suitable Rating		1	

**IX Precautions to be followed**

1. CTs of proper ratio should be used so that currents under normal condition are equal in primary and secondary windings.
2. Tapping of Power Transformer and CT turns ratio should be adjusted simultaneously.
3. Phase difference in primary and secondary should be compensated by proper connections of CTs.
4. Ensure that no load current does not trip the breaker under normal condition.
5. Make sure that voltage applied is very less.

**X Procedure****Part I**

1. Make the circuit as per the diagram.
2. Ensure that load applied is zero and 3-phase auto-transformer is at zero position.
3. Apply low voltage with the help of auto-transformer.
4. Apply equal load in all the 3 phases and note down the value of voltage and currents in all the three phases.
5. Simulate a Short circuit between any two phases.
6. Note down the values of currents at which circuit breaker trips.
7. Switch off the load and supply.

**Part II**

1. Make the circuit as per the diagram.
2. Ensure that load applied is zero and 3-phase auto-transformer is at zero position.
3. Apply low voltage with the help of auto-transformer.
4. Apply equal load in all the 3 phases and note down the value of voltage and currents in all 3 phases.
5. Simulate an earth fault in any one of the windings and note down the current at which circuit breaker trips.
6. Switch off the load and supply.

**XI Observation Table**

Sr. No.	Type of fault	Normal Current	Fault current
1	Phase to phase fault		
2	Earth fault		

**XII Result(s)**

.....

.....

.....

**XIII Interpretation of results**

.....

.....

.....

**XIV Conclusion and recommendation**

.....

.....

.....

**XV Practical related questions** (Note:- Teacher should provide various questions related to practical-sample given)

1. List out the important faults that may occur on a power transformer
2. Give the factors that cause difficulty in applying circulating current principle to a power transformer. Also provide remedy for each difficulty.
3. Describe with neat diagram the merz price circulating current system for the protection of transformers.
4. State the main difference between an earth relay and an over current relay.





**XVI References/Suggestions for further reading**

1. Book: Mehta V. K ; Rohit Mehta, Principles of Power System ,S.Chand and Co., New Delhi., 2016 ISBN: 978-93-5501-077-3
2. Book: Rao.Sunil S. Switchgear and Protection Khanna Publishers, New Delhi, 2015 ISBN: 978-93-87394-72-8 3
3. Book: Gupta. J. B. Switchgear and Protection S. K. Kataria and Sons, New Delhi, 2015ISBN: 978-93-5014-372-8.
4. <https://www.sciencedirect.com/science/article/pii/S0378779617303516>
5. <https://electrical-engineering-portal.com/download-center/books-and-guides/power-substations/transformer-differential-protection-scheme>

**XVII Suggested Assessment Scheme**

<b>Performance Indicators</b>		<b>Weightage</b>
<b>Process Related: 15 Marks</b>		<b>60 %</b>
1	Selection of meters and components	20%
2	Handling of the relay and load	10%
3	Reading meters accurately	10%
4	connection of circuits	10%
5	Follow safe practices	10%
<b>Product Related: 10 Marks</b>		<b>40%</b>
6	Writing result	10%
7	Interpretation of result	05%
8	Conclusions	05%
9	Practical related questions	15%
10	Submitting the journal in time	05%
<b>Total (25 Marks)</b>		<b>100 %</b>

<b>Marks Obtained</b>			<b>Dated signature of Teacher</b>
<b>Process Related (15)</b>	<b>Product Related (10)</b>	<b>Total (25)</b>	

**Practical No. 8 :** Testing of single-phase preventer for protecting three phase induction motor.

**I Practical Significance**

3- Phase induction motor undergoes various types of abnormal conditions. One of the fault associated with this motor is single phasing. So it is necessary to protect the motor from this fault using a single phasing preventer, otherwise the useful life of the motor decreases due to the thermal stresses.

**II Industry/Employer Expected Outcome(s)**

Select and use different switchgears and protection schemes to maintain the reliability and stability of the power system.

**III Course Level Learning Outcome(s)**

Use suitable protection schemes for alternators, motors ,transformers, busbars and transmission lines.

**IV Laboratory Learning Outcome(s)**

LLO 8.1 Use Single-Phase Preventer for protection of three phase induction motor.

**V Relevant Affective Domain related outcome(s)**

1. Follow safety electrical rules for safe practices.

**VI Relevant Theoretical Background**

When one of the phases connected to a 3-phase induction motor goes out of order due to some reason, the motor runs on two phases. This is known as single phasing and motor is to be disconnected immediately from the supply automatically. This automatic protection can be given to the motor by using single phasing preventer.

**VII Actual Circuit diagram used in laboratory with equipment Specifications**

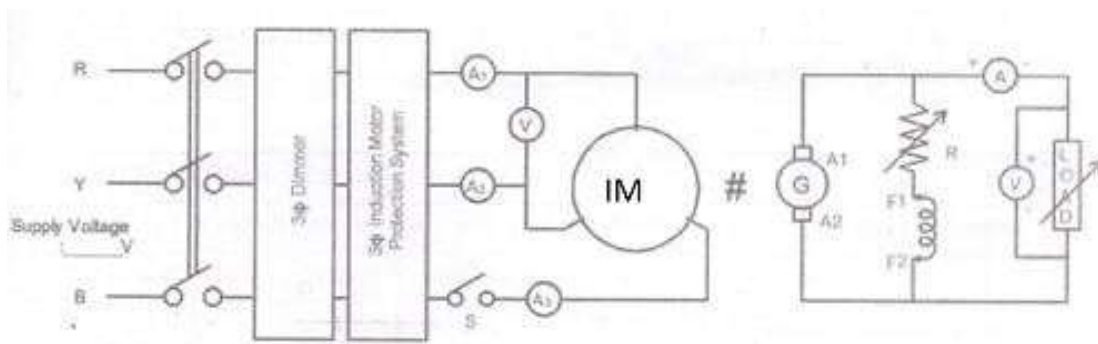

**Fig :8.1. Circuit diagram of three phase Induction Motor protection using single phasing preventer**

**VIII Required Resources/apparatus/equipment with specification**

Sr. No	Name of Resources	Suggested Broad specifications	Quantity	Remark
1	A.C Ammeter	0-20A	3	
2	A.C Voltmeter	0-500V	1	
3	Single Phasing Preventer	0-10A	1	
4	SPST switch	0-20A	1	
5	3 phase induction motor	2-5HP, 440V	1	

**IX Precautions to be followed**

1. Make sure that all connections are tight.
2. Do not touch/make/alter any connection when the circuit is live.
3. All the loads connected should be in OFF position initially.

**X Procedure**

1. Start the motor with a starter.
2. Load the motor to 1/4<sup>th</sup> of rated load.
3. Create single phasing condition by opening switch 'S'.
4. Observe voltage and current values and operation of single phasing preventer.

**XI Observation Table**

Sr.No.	Conditions	Motor Side Current		
		I <sub>1</sub>	I <sub>2</sub>	I <sub>3</sub>
1	Normal			
2	Abnormal			

**XII Result(s)**

.....  
.....  
.....

**XIII Interpretation of results**

.....  
.....  
.....

**XIV Conclusion and recommendation**

.....  
.....  
.....

**XV Practical related questions** (Note:- Teacher should provide various questions related to practical-sample given)

1. Explain the term 'Single phasing'.
2. List out the effects of single phasing.
3. State abnormal conditions in supply system to which motor needs to be protected.
4. Draw a neat labelled diagram of single phasing preventer

.....  
.....  
.....  
.....  
.....  
.....  
.....  
.....  
.....  
.....  
.....  
.....  
.....  
.....  
.....  
.....  
.....  
.....  
.....  
.....



**XVI References/Suggestions for further reading**

1. Book: Rao.Sunil S. Switchgear and Protection Khanna Publishers, New Delhi, 2015 ISBN: 978-93-87394-72-8 3
2. Book: Gupta. J. B. Switchgear and Protection S. K. Kataria and Sons, New Delhi, 2015 ISBN: 978-93-5014-372-8.
3. <https://forumelectrical.com/working-principle-of-single-phase-preventer-relay/>
4. <https://mkp.gem.gov.in/electrical-systems-and-lighting-and-components-and-accessories-and-supplies-electrical-equipment-and-components-and-supplies--electrical-relays-and-accessories-single-phasing-preventer-relay-sppr->

**XVII Suggested Assessment Scheme**

<b>Performance Indicators</b>		<b>Weightage</b>
<b>Process Related: 15 Marks</b>		<b>60 %</b>
1	Selection of meters and components	20%
2	Handling of the meters and components	10%
3	Reading meters accurately	10%
4	connection of circuits	10%
5	Follow safe practices	10%
<b>Product Related: 10 Marks</b>		<b>40%</b>
6	Writing results	10%
7	Interpretation of result	05%
8	Conclusions	05%
9	Practical related questions	15%
10	Submitting the journal in time	05%
<b>Total (25 Marks)</b>		<b>100 %</b>

<b>Marks Obtained</b>			<b>Dated signature of Teacher</b>
<b>Process Related (15)</b>	<b>Product Related (10)</b>	<b>Total (25)</b>	

**Practical No. 9 :** Demonstrate/Simulate transmission line protection by using the impedance/over current relay for various faults.

**I Practical Significance**

Transmission line is the vital part of electric power system and requires the immediate attention of protection engineers for safe guard against the possible faults occurring on them. The probability of faults occurring on the lines is much more due to their greater length and exposure to atmospheric conditions. Less expensive methods namely over current protection or distance protection can be adopted to provide automatic protection to transmission lines and to isolate the smallest possible part of the system.

**II Industry/Employer Expected Outcome(s)**

Select and use different switchgears and protection schemes to maintain the reliability and stability of the power system.

**III Course Level Learning Outcome(s)**

Use suitable protection schemes for alternators, motors ,transformers, busbars and transmission lines.

**IV Laboratory Learning Outcome(s)**

LLO 9.1 Select relevant protection scheme for the given transmission line.

**V Relevant Affective Domain related outcome(s)**

1. Follow safety electrical rules for safe practices.

**VI Relevant Theoretical Background**

In the event of a short circuit, the circuit breaker closest to the fault should open, all other breaker remaining in closed position. In case the nearest circuit breaker to the fault fails to open, backup protection should be provided by the adjacent circuit breakers. The relay operating time should be as short as possible in order to preserve system stability. The common methods of line protection are time graded over current protection, differential protection and distance protection.

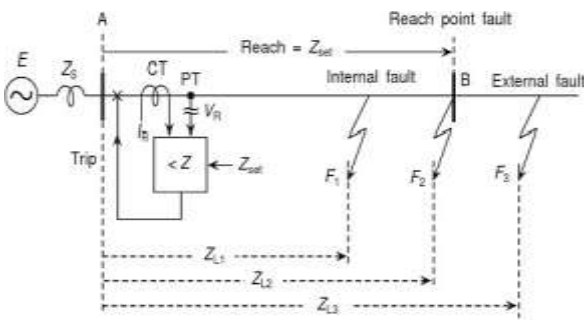

**Distance Protection**

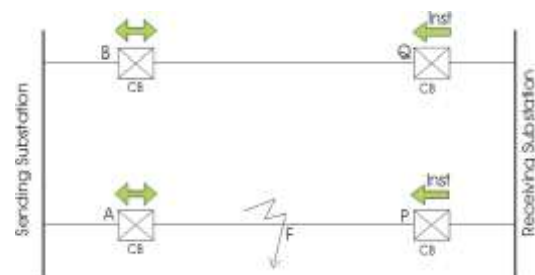

**Over-current Protection for Parallel Feeders**

## VII Actual Circuit diagram used in laboratory with equipment Specifications

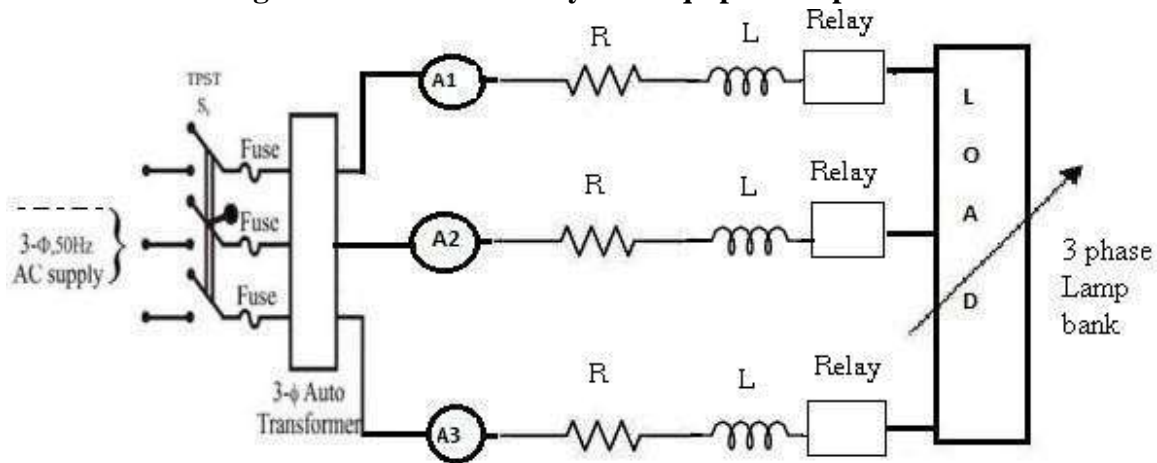

Fig:9.1. Simulation diagram for transmission line protection

## VIII Required Resources/apparatus/equipment with specification

Sr. No	Name of Resources	Suggested specifications	Broad	Quantity	Remark
1	Transmission line protection simulation kit	Standard		3	
2	3 phase autotransformer	Suitable rating		1	
3	AC ammeter	Suitable rating		1	
4	Resistors and inductors	Suitable rating		1	
5	Relay	Suitable rating		1	
6	3 Phase Lamp Bank	Suitable rating			
7	CT and PT	Suitable rating		1	

## IX Precautions to be followed

1. Ensure that connection is tight before giving the supply.
2. Don't touch live parts of the circuit.

## X Procedure

### Part I

1. Make the circuit as per the diagram.
2. Ensure that load applied is zero and 3-phase auto-transformer is at zero position.
3. Apply low voltage with the help of auto-transformer.
4. Apply equal load in all the 3phases and note down the values of currents in all three phases.

5. Short any two lines and note down the currents at which circuit breaker trips.

**Part II**

1. Make the circuit as per the diagram.
2. Ensure that load applied is zero and 3-phase auto-transformer is at zero position.
3. Apply low voltage with the help of auto-transformer.
4. Then increase the load in such a way that current exceeds the preset value of the over current relay.
5. Note down the value of currents at which circuit breaker trips.

**XI Observation Table**

Sr. No.	Type of Fault	Tripping current in Ampere		
		I <sub>1</sub>	I <sub>2</sub>	I <sub>3</sub>
1	Short Circuit			
2	Over current			

**XII Result(s)**

.....  
 .....  
 .....

**XIII Interpretation of results**

.....  
 .....  
 .....

**XIV Conclusion and recommendation**

.....  
 .....  
 .....

**XV Practical related questions** (Note:- Teacher should provide various questions related to practical-sample given)

1. State the requirements of protection of lines?
2. Describe distance protection scheme for the protection of feeders.
3. Draw a neat labelled diagram of differential pilot wire method for protection of feeders.
4. List out the types of relays used for transmission line protection.



**XVI References/Suggestions for further reading**

1. Book: Rao.Sunil S. Switchgear and Protection Khanna Publishers, New Delhi, 2015 ISBN: 978-93-87394-72-8 3
2. Book: Gupta. J. B. Switchgear and Protection S. K. Kataria and Sons, New Delhi, 2015 ISBN: 978-93-5014-372-8.
3. <https://electrical-engineering-portal.com/overcurrent-distance-differential-protection>
4. [https://www.researchgate.net/publication/368063713\\_Design\\_and\\_Implementation\\_of\\_Overcurrent\\_Relay\\_to\\_Protect\\_the\\_Transmission\\_Line](https://www.researchgate.net/publication/368063713_Design_and_Implementation_of_Overcurrent_Relay_to_Protect_the_Transmission_Line)

**XVII Suggested Assessment Scheme**

Performance Indicators		Weightage
<b>Process Related: 15 Marks</b>		<b>60 %</b>
1	Selection of meters and components	20%
2	Handling of the meters and components	10%
3	Reading meters accurately	10%
4	connection of circuits	10%
5	Follow safe practices	10%
<b>Product Related: 10 Marks</b>		<b>40%</b>
6	Writing results	10%
7	Interpretation of result	05%
8	Conclusions	05%
9	Practical related questions	15%
10	Submitting the journal in time	05%
<b>Total (25 Marks)</b>		<b>100 %</b>

Marks Obtained			Dated signature of Teacher
Process Related (15)	Product Related (10)	Total (25)	

**Practical No. 10 :** Demonstration of Thyrite type lightning arrester using video /Dismantling the same.

**I Practical Significance**

Lightning is one of the nature's most powerful and destructive phenomenon. So it is necessary to protect the insulation and conductors of electrical power system and telecommunication system from the damaging effect of lightning using various types of lightning arrestors. By dismantling one can identify the various parts of thyrite type arrester and can do maintenance or repair.

**II Industry/Employer Expected Outcome(s)**

Select and use different switchgears and protection schemes to maintain the reliability and stability of the power system.

**III Course Level Learning Outcome(s)**

Select suitable protection schemes for power system against over voltages.

**IV Laboratory Learning Outcome(s)**

LLO 10.1 Identify different parts of the Lightning Arrester.

**V Relevant Affective Domain related outcome(s)**

1. Follow safety electrical rules for safe practices.

**VI Relevant Theoretical Background**

Lightning arrester is a protective device which conducts in the event of high voltage surge on the power system. The basic form of surge diverter consists of a spark gap in series with a nonlinear resistor. Types of arresters are: Rod gap, Multi gap, Horn gap, Expulsion type and thyrite type arrester.



**Photograph of Thyrite type arrester**

**VII Actual Circuit diagram used in laboratory with equipment Specifications**

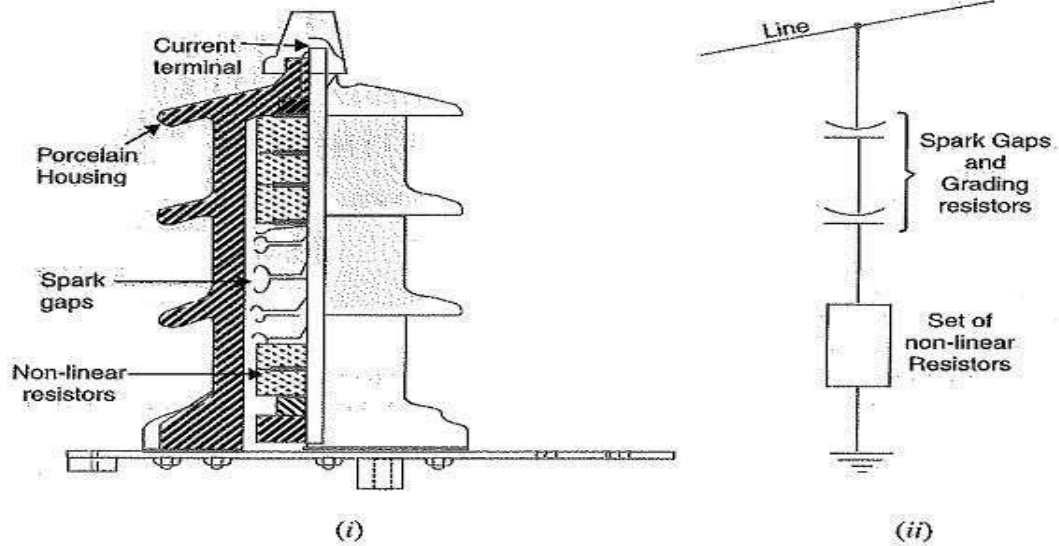

**VIII Required Resources/apparatus/equipment with specification**

Sr. No	Name of Resources	Suggested Broad specifications	Quantity	Remark
1	Lightning arrester	200A(suitable rating)	01	
2	Screwdriver	Set	01	
3	Spanner	Set	01	

**IX Precautions to be followed**

1. Make sure that the lightning arrester is disconnected from the supply.
2. Tighten the cover properly while reassembling

**X Procedure**

1. Remove the outer cover.
2. Observe and identify the parts.
3. Note down the material with which each part is made up of.
4. Reassemble it correctly.

**XI Observation Table**

<b>Sr. No.</b>	<b>Name of the part</b>	<b>Material used</b>	<b>Function</b>

**XII Result(s)**

.....

.....

.....

**XIII Interpretation of results**

.....

.....

.....

**XIV Conclusion and recommendation**

.....

.....

.....

**XV Practical related questions** (Note:- Teacher should provide various questions related to practical-sample given)

1. State the causes of over voltages in the power system.
2. State the harmful effects of lightning on power system.
3. Name the lightning arrester preferred in industry.
4. List out any two resistor materials used in lightning arrester.

.....

.....

.....

.....

.....

.....

.....

.....

.....

.....

.....

.....

.....

.....

.....

.....

.....

.....

.....

.....

.....

.....

.....

.....

.....

.....



**XVI References/Suggestions for further reading**

1. Book: Rao.Sunil S. Switchgear and Protection Khanna Publishers, New Delhi, 2015 ISBN: 978-93-87394-72-8 3
2. Book: Gupta. J. B. Switchgear and Protection S. K. Kataria and Sons, New Delhi, 2015ISBN: 978-93-5014-372-8.
3. <https://circuitglobe.com/types-of-lightning-arresters.html>
4. <https://renownpower.com/types-of-lightning-arrester/>

**XVII Suggested Assessment Scheme**

<b>Performance Indicators</b>		<b>Weightage</b>
<b>Process Related: 15 Marks</b>		<b>60 %</b>
1	Identification of parts	20%
2	Handling of the tools / components	10%
3	Recognizing the material of parts	10%
4	Working in team	10%
5	Follow safe practices	10%
<b>Product Related: 10 Marks</b>		<b>40%</b>
6	Writing results	10%
7	Interpretation of result	05%
8	Conclusions	05%
9	Practical related questions	15%
10	Submitting the journal in time	05%
<b>Total (25 Marks)</b>		<b>100 %</b>

<b>Marks Obtained</b>			<b>Dated signature of Teacher</b>
<b>Process Related (15)</b>	<b>Product Related (10)</b>	<b>Total (25)</b>	

**Practical No. 11 :** Demonstrate process of carrying out neutral earthing at different substations / locations or with suitable media.

**I Practical Significance**

Earthing system of an electrical network acts as a safety measure to protect human life as well as equipment. The main objective of earthing system is to provide an alternate path for dangerous fault current to flow so as to avoid shock and damage to the equipment. Substation Earthing consists of Grounding electrodes and ground bus connected to form mesh. The neutral earthing is provided for the purpose of protection against arcing ground, unbalanced voltages and lightning.

**II Industry/Employer Expected Outcome(s)**

Select and use different switchgears and protection schemes to maintain the reliability and stability of the power system.

**III Course Level Learning Outcome(s)**

Select suitable protection schemes for power system against over voltages.

**IV Laboratory Learning Outcome(s)**

LLO 10.1 Describe the step by step procedure to carry out Neutral Earthing.

**V Relevant Affective Domain related outcome(s)**

1. Follow safety electrical rules for safe practices.

**VI Relevant Theoretical Background**

The process of connecting non-current carrying metal parts (metallic enclosure) of the electrical equipment to earth is called equipment earthing. When some electrical part of the power system is connected to earth, it is called as system grounding. There are two types of earthing namely pipe earthing and plate earthing.

A neutral earthing system is a system in which the neutral point or star point of star connected three phase winding of power transformers, generators, motors is connected to earth, either solidly or through a resistance or through a reactance of value sufficient to materially reduce transients, and to give sufficient current for selective earth fault protection devices to operate.

Earthing mat is made by joining the number of rods through copper conductors it reduces the overall grounding resistance such type of system helps in limiting the ground potential. Number of grounding rods depends upon the fault level of substation. One rod per 250 amperes. Earthing mat is mostly used in place where large fault current is experienced.

VII Illustrative photographs of earthing

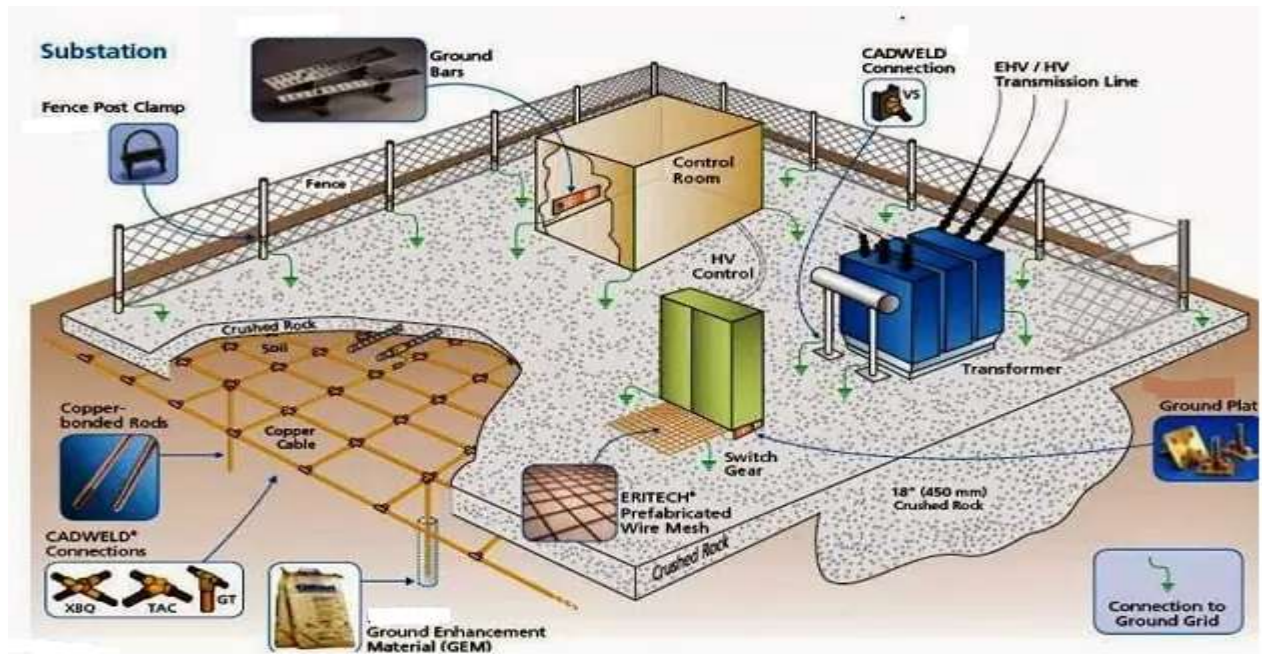

Fig:11.1.Substation Earthing System Design

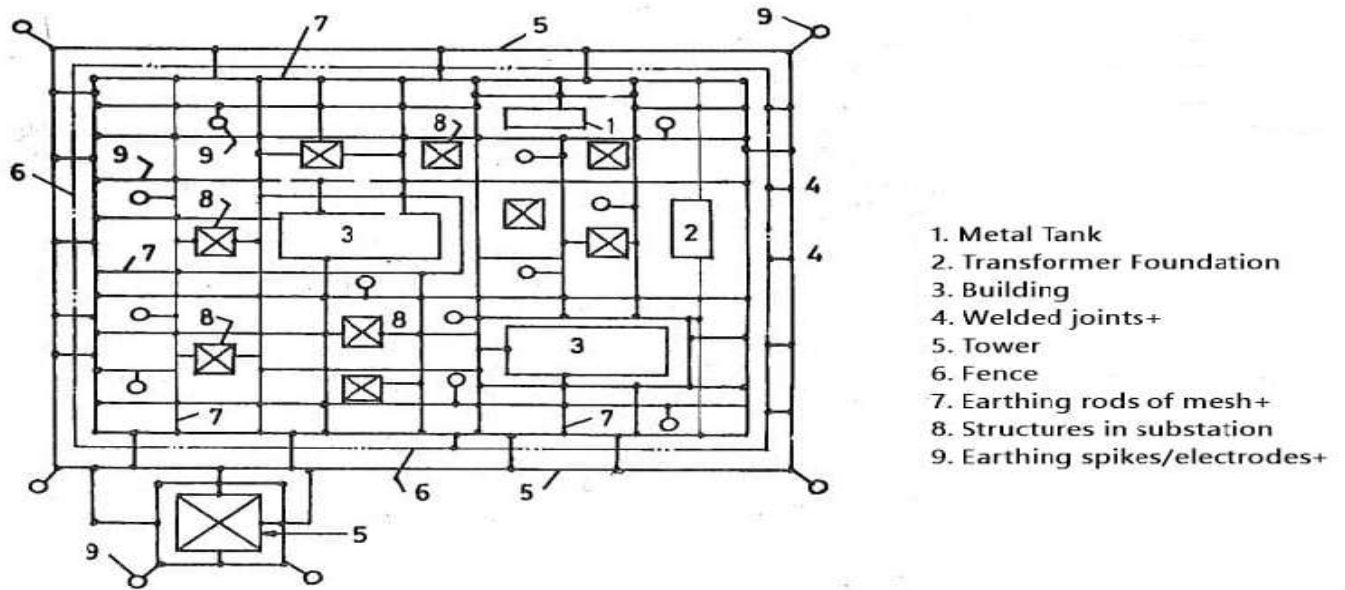

Fig:11.2. Substation Earthing system

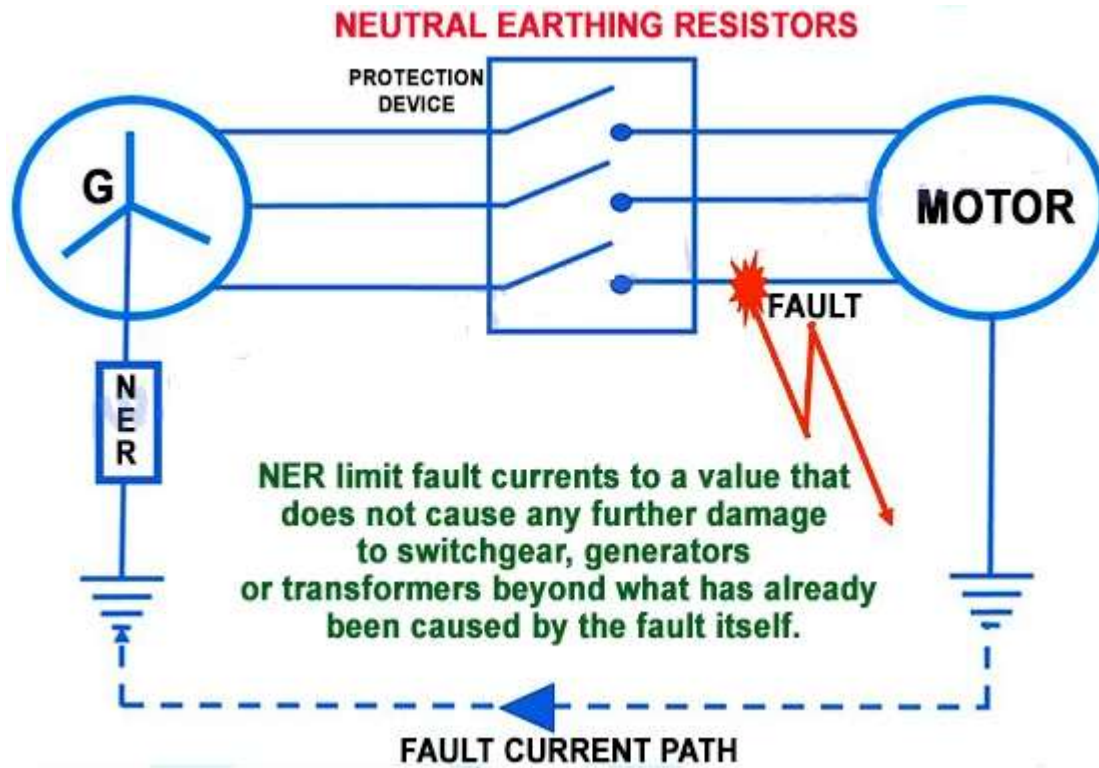

Fig:11.3. Neutral earthing system for alternator

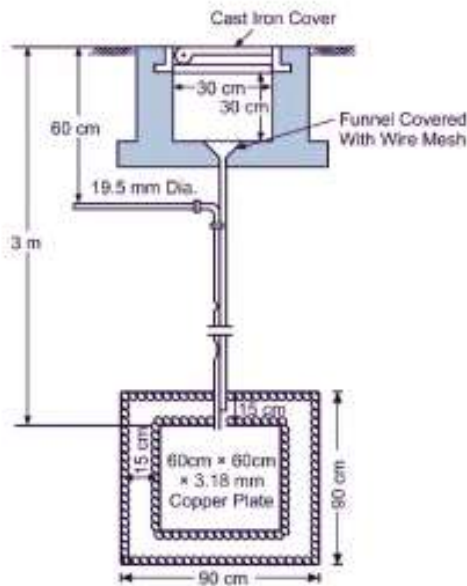

Fig:11.4. Plate Earthing

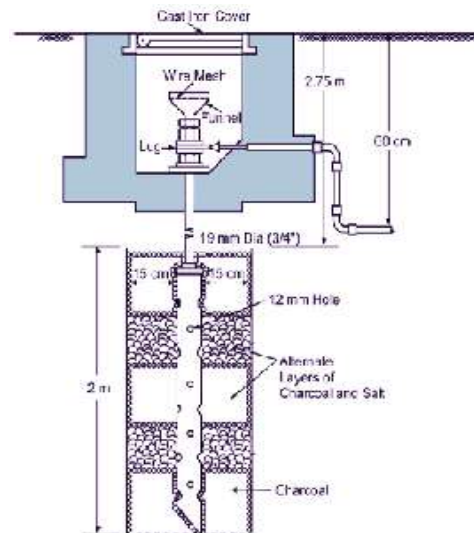

Fig:11.5. Pipe Earthing

**VIII Required Resources/apparatus/equipment with specification**

Sr. No	Name of Resources	Suggested Broad specifications	Quantity	Remark
1	GI/Copper earthing plate	Standard Size	01	
2	GI/Copper pipe	Standard Size	01	
3	GI/Copper wire	Standard Size	01	

**IX Precautions to be followed**

1. Switch off the main supply before demonstration.
2. Don't touch live parts while observing earthing system.
3. Observe all the parts properly.

**X Procedure****Part I (Residential Earthing /LV)**

1. Observe the various material of the earthing system thoroughly.
2. Note down the various material with specification of the earthing system.

**Part II (Substation earthing / HV)**

1. Observe the various material of the substation earthing thoroughly.
2. Note down the various material with specification of the substation earthing system.

**XI Observations: (Student shall draw the diagram and write down the material and specification after visiting the substation/site)****Part I (Residential Earthing /LV)**

Sr. No.	Name of Material	Specification

**Part II (Substation earthing/ HV)**

<b>Sr. No</b>	<b>Types of neutral Earthing</b>	<b>Symbol</b>	<b>Specification</b>

**XII Result(s)**

.....  
.....  
.....

**XIII Interpretation of results**

.....  
.....  
.....

**XIV Conclusion and recommendation**

.....  
.....  
.....

**XV Practical related questions** (Note:- Teacher should provide various questions related to practical-sample given)

1. Differentiate between neutral earthing and equipment earthing.
2. State the function of substation earthing.
3. State the condition for typical effective earthing system.
4. State two material required for earth electrode.
5. What is the function of salt and charcoal in an earthing system?

.....  
.....  
.....  
.....  
.....



**XVI References/Suggestions for further reading**

1. Book: Rao.Sunil S. Switchgear and Protection Khanna Publishers, New Delhi, 2015 ISBN: 978-93-87394-72-8 3
2. Book: Gupta. J. B. Switchgear and Protection S. K. Kataria and Sons, New Delhi, 2015 ISBN: 978-93-5014-372-8.
3. <https://axis-india.com/introduction-to-substation-earthing/>
4. <https://electrical-engineering-portal.com/types-of-neutral-earthing-in-power-distribution-part-1>

**XVII Suggested Assessment Scheme**

Performance Indicators		Weightage
<b>Process Related: 15 Marks</b>		<b>60 %</b>
1	Identification of Parts	20%
2	Recognizing the material of parts	10%
3	Working in team	10%
4	Follow safe practices	10%
5	Identification of Parts	10%
<b>Product Related: 10 Marks</b>		<b>40%</b>
6	Noting down the observation	10%
7	Interpretation of result	05%
8	Conclusions	05%
9	Practical related questions	15%
10	Submitting the journal in time	05%
<b>Total (25 Marks)</b>		<b>100 %</b>

Marks Obtained			Dated signature of Teacher
Process Related (15)	Product Related (10)	Total (25)	