

SCHEME :K

Name : _____
Roll No.: _____ Year : 20 ____ 20 ____
Exam Seat No. : _____

LABORATORY MANUAL FOR MAINTENANCE OF ELECTRICAL EQUIPMENTS (316328)



ELECTRICAL ENGINEERING GROUP



**MAHARASHTRA STATE BOARD OF
TECHNICAL EDUCATION, MUMBAI
(Autonomous)(ISO21001:2018)(ISO/IEC27001:2013)**

VISION

To ensure that the Diploma level Technical Education constantly matches the latest requirements of Technology and industry and includes the all-round personal development of students including social concerns and to become globally competitive, technology led organization.

MISSION

To provide high quality technical and managerial manpower, information and consultancy services to the industry and community to enable the industry and community to face the challenging technological & environmental challenges.

QUALITY POLICY

We, at MSBTE are committed to offer the best in class academic services to the students and institutes to enhance the delight of industry and society. This will be achieved through continual improvement in management practices adopted in the process of curriculum design, development, implementation, evaluation and monitoring system along with adequate faculty development programs.

CORE VALUES

MSBTE believes in the following:

- Skill development in line with industry requirements.
- Industry readiness and improved employability of Diploma holders.
- Synergistic relationship with industry.
- Collective and Cooperative development of all stake holders.
- Technological interventions in societal development.
- Access to uniform quality technical education.

A Laboratory Manual For

MAINTENANCE OF ELECTRICAL EQUIPMENTS

(316328)

Semester – VI

(EE/EP)

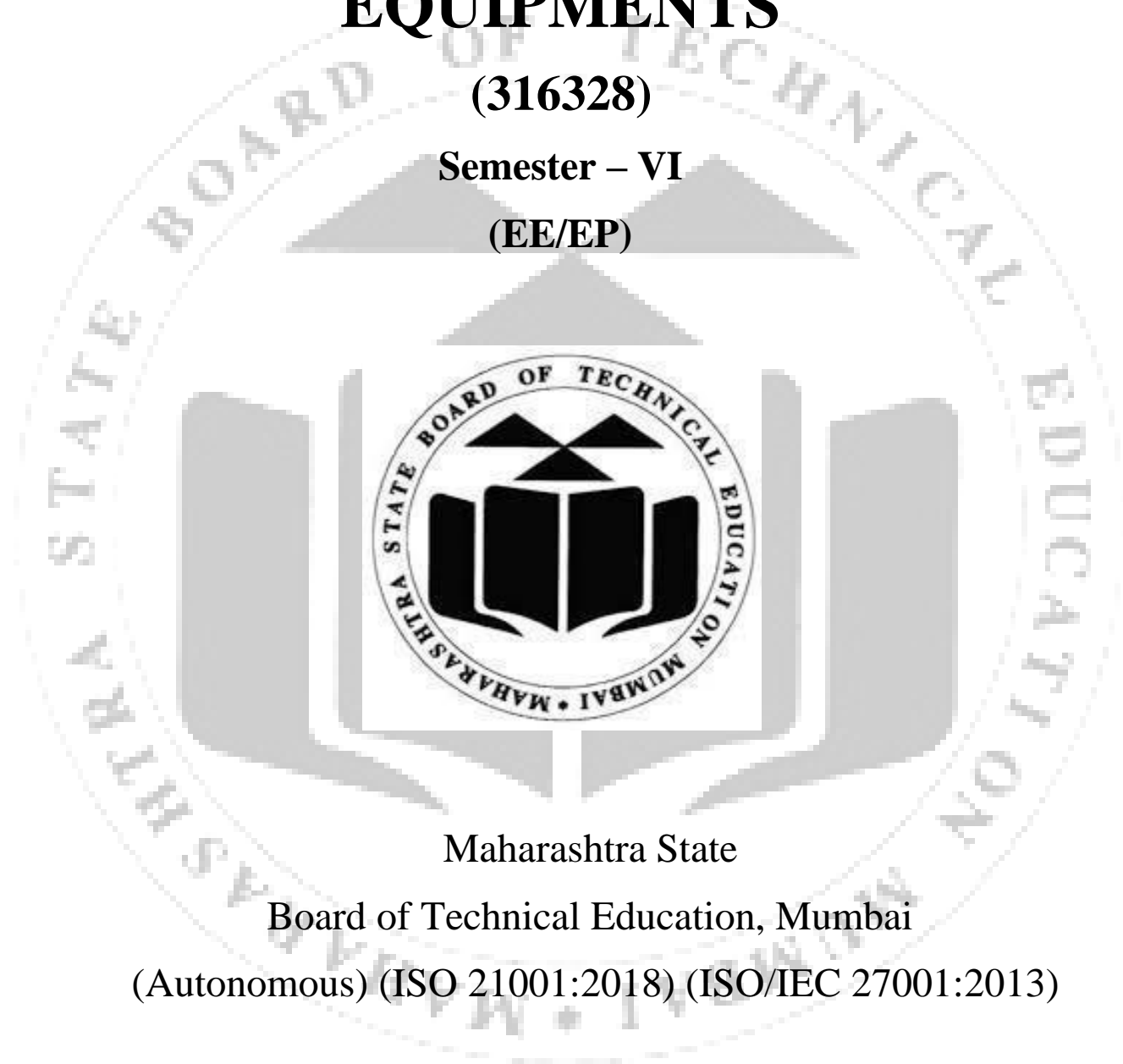

Maharashtra State

Board of Technical Education, Mumbai

(Autonomous) (ISO 21001:2018) (ISO/IEC 27001:2013)

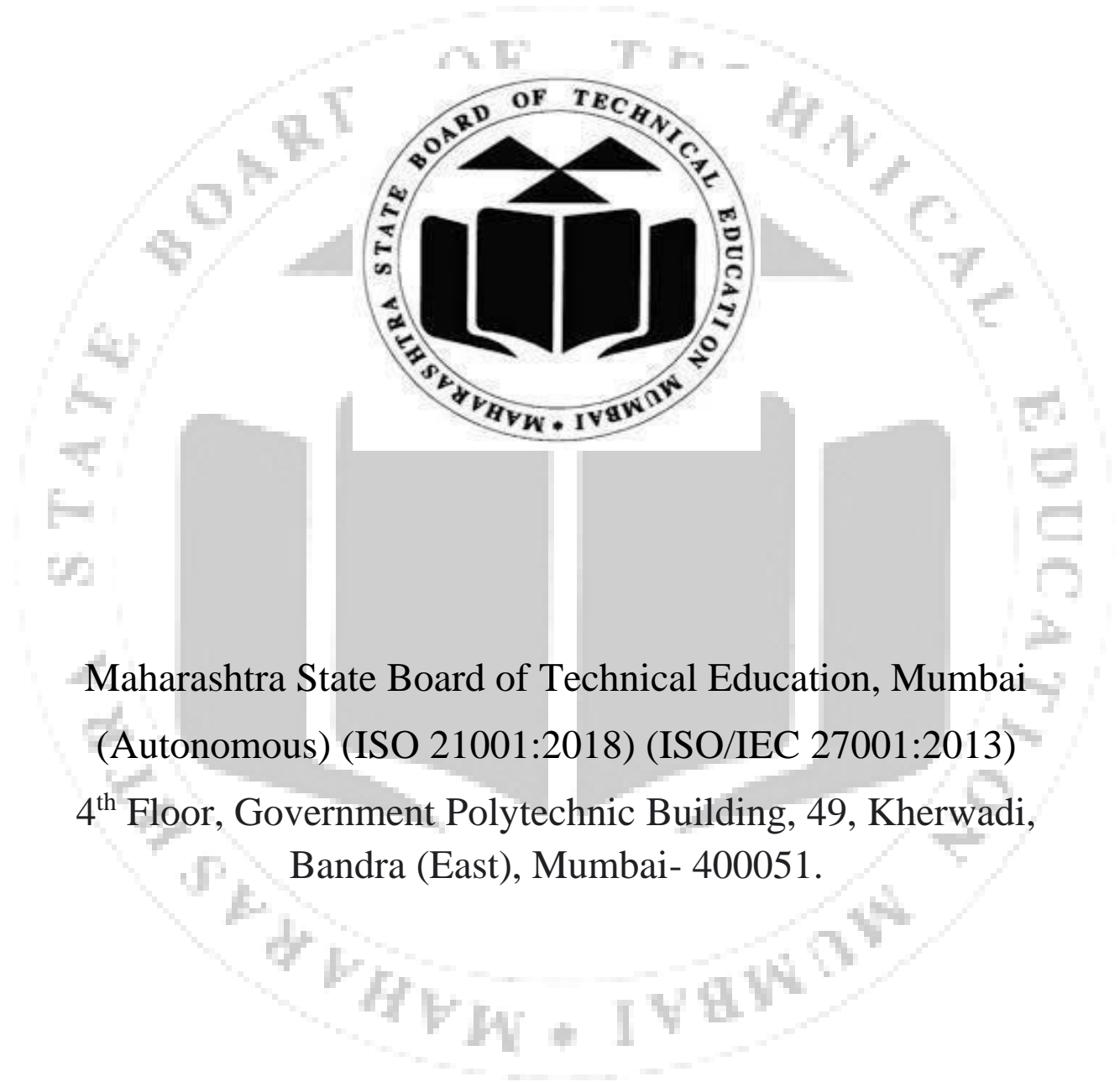

Maharashtra State Board of Technical Education, Mumbai
(Autonomous) (ISO 21001:2018) (ISO/IEC 27001:2013)
4th Floor, Government Polytechnic Building, 49, Kherwadi,
Bandra (East), Mumbai- 400051.



**MAHARASHTRA STATE BOARD OF TECHNICAL
EDUCATION
Certificate**

This is to certify that Mr./Ms.....

Roll No.of Sixth Semester of Diploma
in..... of Institute
.....

(Code:) has completed the term work satisfactorily in
course **MAINTENANCE OF ELECTRICAL EQUIPMENTS**
(316328) for the academic year 20.....to 20..... as prescribed
in the curriculum.

Place:

Enrollment No:

Date:

Exam Seat No:

Subject Teacher

Head of Department

Principal



Preface

The primary focus of any engineering laboratory/field work in the technical education system is to develop the much needed industry relevant competencies and skills. With this in view, MSBTE embarked on this innovative 'K' Scheme curricula for engineering diploma programs with outcome-based education as the focus and accordingly, relatively large amount of time is allotted for the practical work. This displays the great importance of laboratory work making each teacher, instructor and student to realize that every minute of the laboratory time need to be effectively utilized to develop these outcomes, rather than doing other mundane activities. Therefore, for the successful implementation of this outcome-based curriculum, every practical has been designed to serve as a maintenance of electrical equipment's to develop this industry identified competency in every student. The practical skills are difficult to develop through "chalk and duster" activity in the classroom situation. Accordingly, the "K" scheme laboratory manual development team designed the practical to focus on the outcomes, rather than the traditional age old practice of conducting practical to 'verify the theory' (which may become a byproduct along the way).

This laboratory manual is designed to help all stakeholders, especially the students, teachers and instructors to develop in the student the pre-determined outcomes. It is expected from each student that at least a day in advance, they have to thoroughly read through the concerned practical procedure that they will do the next day and understand the minimum theoretical background associated with the practical. Every practical in this manual begins by identifying the Practical Significance, industry relevant skills, course level Learning outcomes and Relevant Affective Domains which serve key focal point for doing the practical. The students will then become aware about the skills they will achieve through procedure shown there and necessary precautions to be taken, which will help them to apply in solving real-world problems in their professional life.

This manual also provides guidelines to teachers and instructors to effectively facilitate student-centered lab activities through each practical exercise by arranging and managing necessary resources in order that the students follow the procedures and precautions systematically ensuring the achievement of outcomes in the students.

The aim of this course is to help the student to attain the following industry identified competency through various teaching learning experiences: Maintain different types of electrical equipment following safe practices.

Although best possible care has been taken to check for errors (if any) in this laboratory manual, perfection may elude us as this is the first edition of this manual. Any errors and suggestions for improvement are solicited and highly welcome.

Program Outcomes (POs) to be achieved through this course learning

- **PO 1. Basic and Discipline specific knowledge:** Apply knowledge of basic mathematics, sciences and engineering fundamentals and engineering specialization to solve the engineering problems.
- **PO 2. Problem analysis:** Identify and analyse well-defined engineering problems using codified standard methods.
- **PO 3. Design/ development of solutions:** Design solutions for well-defined technical problems and assist with the design of system components or processes to meet specified needs.
- **PO 4. Engineering tools, Experimentation and Testing:** Apply modern engineering tools and appropriate technique to conduct standard tests and measurements.
- **PO 5. Engineering practices for society, sustainability and environment:** Apply appropriate technology in context of society, sustainability, environment and ethical practices.
- **PO 6. Project Management:** Use engineering management principles individually, as a team member or a leader to manage projects and effectively communicate about well-defined engineering activities.
- **PO 7. Life-long learning:** Ability to analyse individual needs and engage in updating in the context of technological changes.

List of Relevant expected psychomotor domain Skills

This Lab manual intends to develop expected psychomotor domain skills of students. The skills mentioned below will be developed through the experiments performed in this Laboratory.

1. Ability to make connections.
2. To use the vocabulary of electrical engineering.
3. To identify and measure the quantities using various measuring instruments.
4. Ability to adjust the components.
5. Ability to perform preventive maintenance tasks such as cleaning, lubrication, tightening, and insulation checking.
6. Execution of troubleshooting procedures to identify and rectify electrical faults systematically.

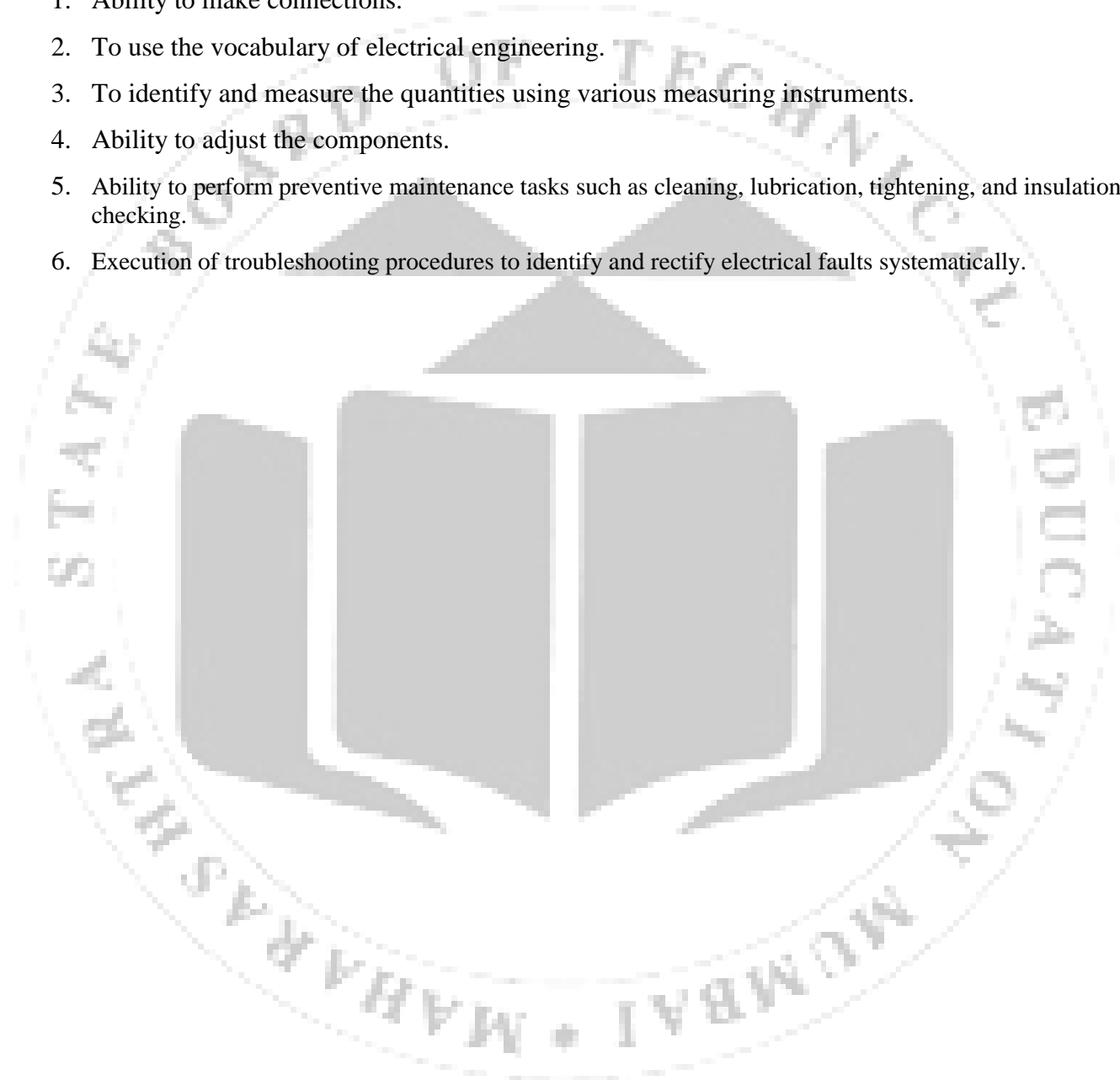

Practical-Course Outcome Matrix

COURSE LEVEL LEARNING OUTCOMES (COS)

- CO1 - Follow safety norms to prevent accidents while using electrical equipment.
- CO2 - Test electrical equipment.
- CO3 - Maintain rotating electrical machines.
- CO4 - Maintain single phase and three phase transformers.
- CO5 - Maintain insulation systems of electrical equipment.

Sr. No.	Title of the Practical	CO1	CO2	CO3	CO4	CO5
1	* Demonstration of Fire extinguisher available in the institute.	✓	-	-	-	-
2	* Demonstration of artificial respiration (Any convenient method).	✓	-	-	-	-
3	* Measurement of earth resistance of electrical laboratory equipment.	✓	-	-	-	-
4	*Protective class of a given electric equipment.	✓	-	-	-	-
5	* Visit BIS portal (bis.gov.in) for getting ISI mark/obtaining a license for electrical equipment's and prepare a report for it.	✓	-	-	-	-
6	* Dismantle and reassemble the given electrical machine and identify the various parts.	-	✓	-	-	-
7	* Use of instruments for testing/ maintenance of given electrical equipment.	-	✓	-	-	-
8	* Testing of given 70 W or higher rating LED for ingress of water to confirm the IP rating	-	✓	-	-	-
9	Maintenance of given induction motor.	-	-	✓	-	-
10	Maintenance of given transformer.	-	-	-	✓	-
11	Diagnosis and rectification of faults for a ceiling fan running slow.	-	-	✓	-	-
12	Diagnosis and rectification of faults for a ceiling fan running in reverse direction.	-	-	✓	-	-
13	Measurement of winding resistance of a single-phase induction motor by V-I method.	-	-	✓	-	-
14	* Reduced voltage running up test of three phase induction motor	-	-	✓	-	-

Sr. No.	Title of the Practical	CO1	CO2	CO3	CO4	CO5
15	Measurement of phase winding resistance of a three-phase induction motor by V-I method.	-	-	✓	-	-
16	Measurement of phase winding resistance of a three-phase induction motor by V-I method.	-	-	✓	-	-
17	* Phasing out test of the three-phase transformer.	-	-	-	✓	-
18	* Polarity test of three phase transformer	-	-	-	✓	-
19	Back-to-Back test on two identical single phase Transformers.	-	-	-	✓	-
20	Dielectric strength test of transformer oil.	-	-	-	-	✓
21	Test insulation resistance and dielectric strength of the windings of a single-phase induction motor.	-	-	-	-	✓
22	Test insulation resistance and dielectric strength of the windings of a three-phase induction motor.	-	-	-	-	✓
23	Measurement of insulation resistance of single-phase induction motor.	-	-	-	-	✓
24	Measurement of insulation resistance of three phase induction motor.	-	-	-	-	✓
25	Measurement of insulation resistance of single-phase transformer.	-	-	-	-	✓
26	Measurement of insulation resistance of three phase transformer.	-	-	-	-	✓

Guidelines to Teachers

1. Teacher should provide the guideline with demonstration of practical to the students with all features.
2. Teacher shall explain prior concepts to the students before starting of each experiment.
3. Involve students in performance of each experiment.
4. Teacher should ensure that the respective skills and competencies are developed in the students after the completion of the practical exercise.
5. Teachers should give opportunity to students for hands on experience after the demonstration.
6. Teacher is expected to share the skills and competencies to be developed in the students.
7. Teacher may provide additional knowledge and skills to the students even though not covered in the manual but are expected the students by the industry. Circuit diagrams provided in manual include major components only with connections based on general concept. Teachers shall provide inputs to students for connections of additional components if required or any specific connection.
8. Finally give practical assignment and assess the performance of students based on task assigned to check whether it is as per the instructions.

Instructions for Students

1. Listen carefully the lecture given by teacher about subject, curriculum, learning structure, skills to be developed.
2. Organize the work in the group and make record all programs.
3. Students shall develop maintenance skill as expected by industries.
4. Student shall attempt to develop related hand-on skills and gain confidence.
5. Student shall develop the habits of evolving more ideas, innovations, skills etc. those included in scope of manual.
6. Student shall refer technical magazines.
7. Student should develop habit to submit the practical's on date and time.
8. Student should well prepare while submitting write-up of exercise.
9. Attach/paste separate papers wherever necessary.
10. Circuit diagrams provided in manual include major components only with connections based on general concept. Students shall seek inputs from teachers for connections of additional components if required or any specific connection.

Content Page

List of Practical's and Progressive Assessment Sheet

Sr. No.	Title of the Practical	Page no.	Date of Performance	Date of Submission	Assessment Marks (25)	Dated sign. of Teacher	Remarks (If any)
1	* Demonstration of Fire extinguisher available in the institute.	01					
2	* Demonstration of artificial respiration (Any convenient method).	07					
3	* Measurement of earth resistance of electrical laboratory equipment.	15					
4	*Protective class of a given electric equipment.	21					
5	* Visit BIS portal (bis.gov.in) for getting ISI mark/obtaining a license for electrical equipment's and prepare a report for it.	28					
6	* Dismantle and reassemble the given electrical machine and identify the various parts.	35					
7	* Use of instruments for testing/ maintenance of given electrical equipment.	42					
8	* Testing of given 70 W or higher rating LED for ingress of water to confirm the IP rating.	53					
9	Maintenance of given induction motor.	58					
10	Maintenance of given transformer.	66					
11	Diagnosis and rectification of faults for a ceiling fan running slow.	72					

Sr. No.	Title of the Practical	Page no.	Date of Performance	Date of Submission	Assessment Marks (25)	Dated sign. of Teacher	Remarks (If any)
12	Diagnosis and rectification of faults for a ceiling fan running in reverse direction.	78					
13	Measurement of winding resistance of a single-phase induction motor by V-I method.	85					
14	* Reduced voltage running up test of three phase induction motor.	90					
15	Measurement of phase winding resistance of a three-phase induction motor by V-I method.	96					
16	Measurement of phase winding resistance of a three-phase induction motor by V-I method.	102					
17	* Phasing out test of the three-phase transformer.	109					
18	* Polarity test of three phase transformer.	115					
19	Back-to-Back test on two identical single phase Transformers.	122					
20	Dielectric strength test of transformer oil.	128					
21	Test insulation resistance and dielectric strength of the windings of a single-phase induction motor.	134					
22	Test insulation resistance and dielectric strength of the windings of a three-phase induction motor.	140					

Sr. No.	Title of the Practical	Page no.	Date of Performance	Date of Submission	Assessment Marks (25)	Dated sign. of Teacher	Remarks (If any)
23	Measurement of insulation resistance of single-phase induction motor.	146					
24	Measurement of insulation resistance of three phase induction motor.	152					
25	Measurement of insulation resistance of single-phase transformer.	157					
26	Measurement of insulation resistance of three phase transformer.	163					

Note : Out of above suggestive LLOs -

- '*' Marked Practical's (LLOs) Are mandatory.
- Minimum 80% of above list of lab experiment are to be performed.
- Judicial mix of LLOs are to be performed to achieve desired outcomes.

Practical No. 1: Demonstration of Fire extinguisher available in the institute.

I Practical Significance:

The demonstration of fire extinguishers helps students understand their types, uses, and limitations while developing confidence to operate them during emergencies. It also promotes safety awareness in labs and workshops, emphasizing the importance of observing safety while working with electrical installations, appliances, and panels. Proper knowledge of safety accessories and procedures not only protects human life but also enhances the quality and life of machines, equipment, wires, and cables.

II Industry/Employer Expected Outcome(s)

To gain practical skills and awareness in fire and electrical safety, so they can handle emergencies be confidently and ensure the safe use and longer life of equipment in workshops and industries.

III Course Level Learning Outcome(s)

CO1 - Follow safety norms to prevent accidents while using electrical equipment.

IV Laboratory Learning Outcome(s)

LLO 1.1 Use fire extinguishers to extinguish the fire.

V Relevant Affective Domain related outcome(s)

Students will develop a responsible attitude toward safety and show concern for protecting themselves, others, and equipment during fire emergencies.

VI Relevant Theoretical Background (With diagrams if required)

A fire extinguisher is a portable fire protection device, typically filled with a dry or wet chemical, designed to extinguish or control small fires in emergency situations. It is not meant for large, uncontrolled fires that have reached the ceiling, pose a risk to the user (such as no escape route, smoke, or explosion hazards), or require the specialized equipment and expertise of a fire brigade. Generally, a fire extinguisher consists of a hand-held cylindrical pressure vessel containing an extinguishing agent, though non-cylindrical designs also exist but are less common.

The different classes of fire extinguishers and the most suitable types for each class of fire are listed below:

Class A - Suitable for paper, wood & textiles.

Type of fire extinguisher - Water, Foam, Dry Powder, Wet Chemical

Class B - Suitable for flammable liquids.

Type of fire extinguisher - Foam, Dry Powder, Carbon Dioxide (CO₂)

Class C - Suitable for flammable gasses.

Type of fire extinguisher - Dry Powder

Class F - Suitable for cooking oil and fat.

Type of fire extinguisher - Wet Chemical

(Note: - There are four different types of water extinguishers: water jet, water spray, water with additives and water mist or fog. Water jet extinguishers work by spraying a jet of water at the burning materials, cooling them and preventing re-ignition. They should not be used on live electrical equipment)

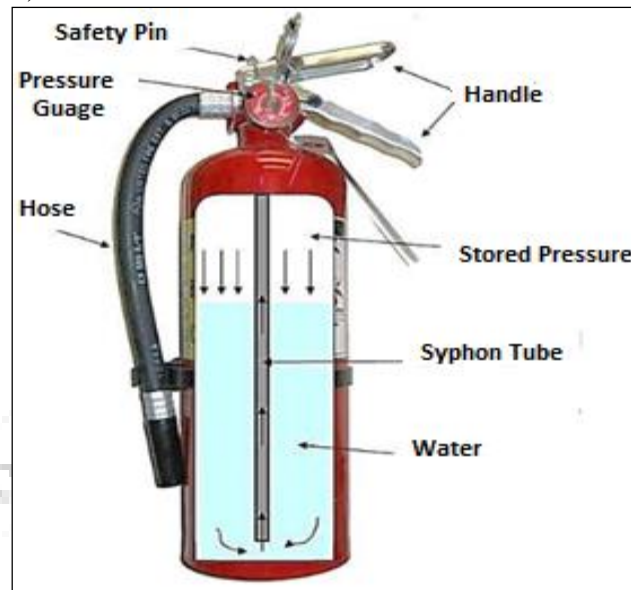

Fig. 1.1 Details of Fire Extinguisher

VII Actual Circuit diagram used in laboratory with equipment Specifications:

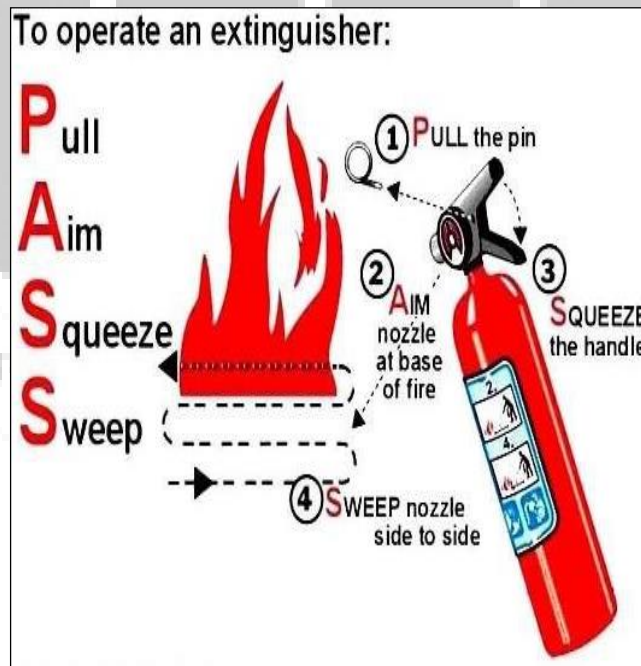

Fig. 1.2 Operation of Fire Extinguisher

- 1. Pull:** Pull the pin to break the tamper seal.
- 2. Aim:** Aim low, pointing the nozzle or hose at the base of the fire. (Do not touch the horn on a CO2 extinguisher since it becomes very cold and can damage skin.)
- 3. Squeeze:** Squeeze the handle to release the extinguishing agent.
- 4. Sweep:** Sweep from side to side at the base of the fire – the fuel source – until the fire is extinguished.

VIII Required Resources / apparatus / equipment with specification:

Sr. No.	Name of Resource	Suggested Broad Specification	Quantity
1.	Type fire extinguisher (any one)	-	1 No.
2.	Recommendations on Safety Procedures and Practices in Electrical Work, Part I: General	IS 5216 (Part 1)	1 No.
3.	Rubber Insulated Electrical Gloves	Working potential: 7,500V	1 No.
4.	Electrical Shock Proof Safety Shoes	Insulation range- 15 to 30KV	1 No.
5.	Safety Jacket	As per Standard	1 No.
6.	Safety Helmet	As per Standard	1 No.
7.	Safety Belt	As per Standard	1 No.
8.	Safety Goggles	As per Standard	1 No.

IX Precautions to be followed:

1. **Never use a fire extinguisher on flames from escaping gas** – leave the area and call emergency services.
2. **Tackle only small fires in their earliest stages** – extinguishers are not for large or uncontrollable fires.
3. **Do not advance unless it is safe** – always keep at least one meter distance from the fire and ensure an escape route.
4. **Do not use more than one extinguisher on a single fire at the same time** – it may cause confusion and reduce visibility.
5. **Fire extinguishers should be handled only by trained persons** – untrained use can be dangerous.

Use of CO₂ type fire extinguisher (Class-B type)**Safety Check:**

- Ensure there is no live electrical equipment nearby if using other types of extinguishers.
- CO₂ extinguishers can be safely used on electrical fires.

Pull the Safety Pin:

- Remove the pin to unlock the extinguisher and make it ready for operation.

Squeeze the Lever:

- Press the handle to start discharging CO₂ gas.

Aim the Nozzle:

- Direct the horn-shaped nozzle **at the base of the fire**, not at the flames.

Discharge CO₂:

- The liquid CO₂ turns into gas and forms a **white cloud**.
- This **displaces oxygen** and **cools the burning material**, smothering the fire.

Move Carefully Closer:

- As the fire diminishes approach cautiously to ensure complete extinguishing.

Post-Use:

- CO₂ leaves no residue, making it ideal for **Class B fires** (flammable liquids) and electrical fires.

X Procedure

1. Check the pressure gauge and safety seal of each extinguisher to ensure it is fully charged and in operable condition.
2. Identify the type of fire extinguisher and read the label to determine the classes of fire for which it is suitable.
3. Select a safe, open area for the demonstration and ensure that it is conducted under proper supervision.
4. Prepare a small controlled fire in a demonstration tray using permitted and safe combustible material.
5. Operate the extinguisher using the PASS method:
 - **P – Pull** the safety pin.
 - **A – Aim** the nozzle at the base of the fire.
 - **S – Squeeze** the handle to discharge the extinguishing agent.
 - **S – Sweep** the nozzle from side to side until the fire is fully extinguished.

XI Results:

.....

.....

.....

.....

XII Interpretation of results:

.....

.....

.....

.....

XIII Conclusion and recommendation

.....

.....

.....

.....

XV References/Suggestions for further reading:

1. <https://www.ifsecglobal.com/fire-extinguishers/choose-right-type-fire-extinguisher/>
2. <https://www.nfpa.org/news-blogs-and-articles/blogs/2023/08/01/fire-extinguisher-types>
3. <https://archive.org/details/gov.in.is.sp.30.2011,assessed on 11th April, 2018>

Assessment Scheme:

Performance Indicators		Weightage
Process Related: (15 Marks)		60%
1	Handling of the components	10 %
2	Identification of component	20 %
3	Measuring value using suitable instrument	20 %
4	Working in team	10 %
Product Related: (10 Marks)		40%
5	Identify theoretical values of given component from datasheets	10 %
6	Interpretation of result	05 %
7	Conclusions	05 %
8	Practical related questions	15 %
9	Submitting the journal in time	05%
Total (25 Marks)		100 %

Marks Obtained			Dated signature of Teacher
Process Related (15)	Product Related (10)	Total (25)	

Practical No. 2: Demonstration of artificial respiration (Any convenient method).

I Practical Significance:

The practical demonstration of artificial respiration equips students with vital life-saving skills, reinforcing first aid knowledge, understanding of respiration, and confidence to act in emergencies. It is highly relevant in industrial and daily life situations, while also promoting teamwork, safety awareness, and responsibility.

II Industry/Employer Expected Outcome(s)

Ability to provide immediate first aid, including artificial respiration, ensuring safety, reducing risks, and handling emergencies confidently.

III Course Level Learning Outcome(s)

CO1- Follow safety norms to prevent accidents while using electrical equipment.

IV Laboratory Learning Outcome(s)

LLO 2.1 Apply artificial respiration in case of emergency.

V Relevant Affective Domain related outcome(s)

Develops empathy, responsibility, and a caring attitude towards the safety and well-being of others during emergencies

VI Relevant Theoretical Background (With diagrams if required)

What is Electric Shock?

Electric shock occurs when a person comes into contact with an electrical energy source, causing the flow of electric current through the body. The effects can range from mild reactions to severe injuries, including tissue damage, skin burns, cardiac arrhythmias, cardiac arrest, or even death. The severity of an electric shock depends on factors such as the voltage level, the part of the body affected, and the type of current involved.

Causes of Electric Shock

Some people are more at risk of electric shock, especially children, adolescents, and adults who work around electricity. Low voltage usually causes minor injuries, while high voltage (over 500 volts) can cause serious tissue damage. Children, however, can still be seriously injured by common household voltages (110–220 volts) from appliances, extension cords, and power cords.

Shock Current (mA)	Effect on Human Body
1 – 5 mA	Slight tingling sensation, usually not harmful
6 – 15 mA	Painful shock, muscular contraction; may be able to let go
16 – 50 mA	Severe shock, muscular contractions; difficult to release grip; possible breathing difficulty
50 – 100 mA	Very severe shock; possible respiratory paralysis; extreme pain
100 – 200 mA	Ventricular fibrillation of the heart may occur; possible fatality if prolonged
> 200 mA	Severe burns, cardiac arrest, and almost certain death

Table 2.1 Shock current and its effects on the human body

Artificial respiration is the process of manually supplying air to a person who has stopped breathing, typically, through the mouth or nose, to sustain life and help them resume normal breathing. The person suffering from an electrical shock is called an electrocuted person or electric shock victim.

Methods of Artificial respiration:

- 1) Schaffer's Method.
- 2) Sylvester's method (Arm lift chest pressure method)
- 3) Nielson's Method (Arm lift back pressure method)
- 4) Mouth to mouth respiration

Schaffer's Method

- Make the victim lie face down (prone position).
- Ask the victim to bend their elbows and place hands near the lower chest.
- Turn the victim's head to the side so they can breathe through the mouth and nose.
- The therapist kneels beside the patient.
- The therapist gently presses on the victim's lower back (loins) using body weight.
- This pressure pushes the diaphragm up, forcing air out of the lungs (**exhalation** – 3 seconds).
- The therapist releases the pressure, allowing the diaphragm to move down and air to enter the lungs
(**Inhalation** – approximately 2 seconds)
- Repeat this process about 12 times per minute or according to normal breathing rate.

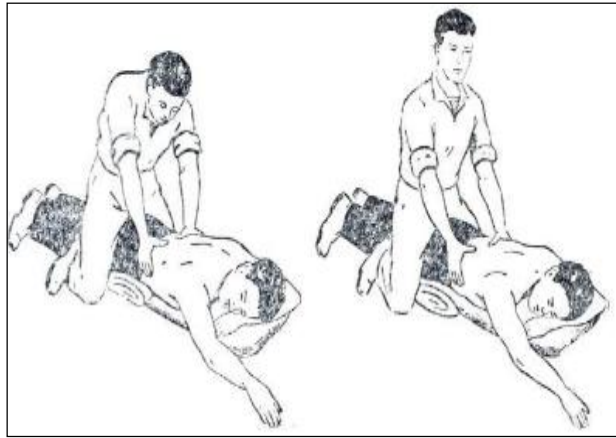

Fig.2.1 Schaffer's Method of Artificial Respiration

Effectiveness of Schaffer's Method:

- Temporarily maintains breathing in emergencies without special equipment.

Limitations of Schaffer's Method:

- Outdated, less effective, and unsuitable for patients with spinal, abdominal, or large body frames.

Sylvester's method (Arm lift chest pressure method)

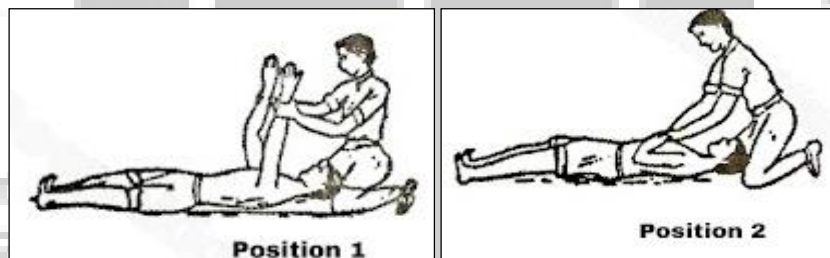

Fig.2.2 Sylvester's method (Arm lift chest pressure method)

- Lay the patient flat on their back.
- Hold the patient's arms just above the wrists.
- Pull the arms upward and backward until they touch the floor above the head.
- Bring the arms back toward the chest and press them down to help air move out of the lungs.

Main Defect:

- The tongue may fall backward and block the windpipe, stopping breathing in about half of the cases.
- A second person is often needed to pull the tongue forward and keep it out.
- If no helper is available, placing a thick pad under the shoulders so the head hangs backward can prevent the tongue from blocking the airway.

Effectiveness of Sylvester's method (Arm lift chest pressure method)

Helps restore breathing by using simple arm and back movements without any equipment.

Limitations of Sylvester's method (Arm lift chest pressure method)

Less effective than modern methods and cannot be used if the patient has spinal injuries or is lying on a hard surface.

Nielson's Method (Arm lift back pressure method)

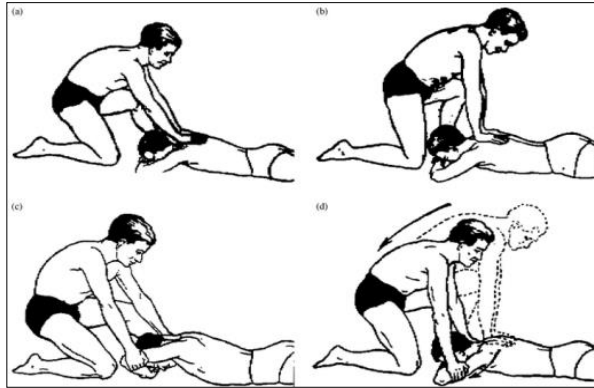

Fig. 2.3 Nielson's Method (Arm lift back pressure method)

Holger-Nielsen Method (Arm Lift–Back Pressure Method):

- The patient is laid face down (on the stomach).
- The patient's head rests on their hands, facing to one side.
- The rescuer stands or kneels near the patient's back.
- Hands are placed on both sides of the back with fingers spread apart.
- Pressure is applied on the back to help air move out (exhalation).
- The patient's arms are then lifted forward to help air move in (inhalation).
- This process is repeated about 10 to 12 times per minute.

Effectiveness of Holger-Nielsen Method (Arm Lift–Back Pressure Method)

Useful for restoring breathing using simple manual movements without special equipment.

Limitations of Holger-Nielsen Method (Arm Lift–Back Pressure Method)

Less effective than modern methods and unsuitable for patients with spinal injuries or chest trauma.

Mouth to mouth respiration

Mouth-to-mouth resuscitation is used to help a person who has fainted or nearly drowned. In this method, the rescuer places their mouth over the victim's mouth and blows air into their lungs to help them breathe. It is done when the person is not breathing properly and is often performed as part of CPR (Cardio Pulmonary Resuscitation).

For a Child Below 8 or an Infant:

- Lay the child on a hard, flat surface.
- Make sure the mouth and throat are clear.
- If something is stuck, gently sweep it out with your fingers.
- If the child vomits, turn them onto their side and clear the mouth.
- Tilt the head back slightly to open the airway.
- Place your mouth over the child's mouth and give two small breaths, watching for the chest to rise.
- Remove your mouth and watch the chest fall as the child exhales.
- Listen and feel for breathing. If the child does not breathe, repeat the steps.

For an Adult:

- Lay the person on a hard, flat surface.
- Check the mouth and throat; remove any visible objects carefully.
- If vomiting occurs, turn the person on their side and clear the mouth. Do not put fingers in the mouth if the person is stiff or having a seizure.
- Tilt the head back slightly and lift the jaw forward to open the airway.
- Pinch the nostrils closed and place your mouth over theirs. Use a mouthpiece if available.
- Give two quick breaths and watch for the chest to rise.
- Release the nostrils and watch the chest fall as the person exhales.
- Listen and feel for breathing. If the person does not breathe, repeat the procedure.

VII Required Resources/apparatus/equipment with specification:

Sr. No.	Name of Resource	Suggested Broad Specification	Quantity
1.	Wooden sticks	Standard	1 No.
2.	Rubber Mat	Standard	1 No.
3.	Recommendations on Safety Procedures and Practices in Electrical Work, Part I: General	IS 5216 (Part 1)	1 No.
4.	Rubber Insulated Electrical Gloves	Working potential: 7,500V	1 No.
5.	Electrical Shock Proof Safety Shoes	Insulation range- 15 to 30 KV	1 No.
6.	Safety Jacket	Standard	1 No.
7.	Safety Helmet	Standard	1 No.
8.	Safety Belt	Standard	1 No.
9.	Safety Goggles	Standard	1 No.
10.	Chart of rescue procedure	Standard	1 No.

VIII Precautions to be followed:

- Make sure you are safely positioned while working.
- Know the proper steps to start and stop the work.
- Wear insulated gloves and shoes.
- Check all safety equipment, like rubber gloves and mats, before use.

IX Results:

.....

.....

.....

.....

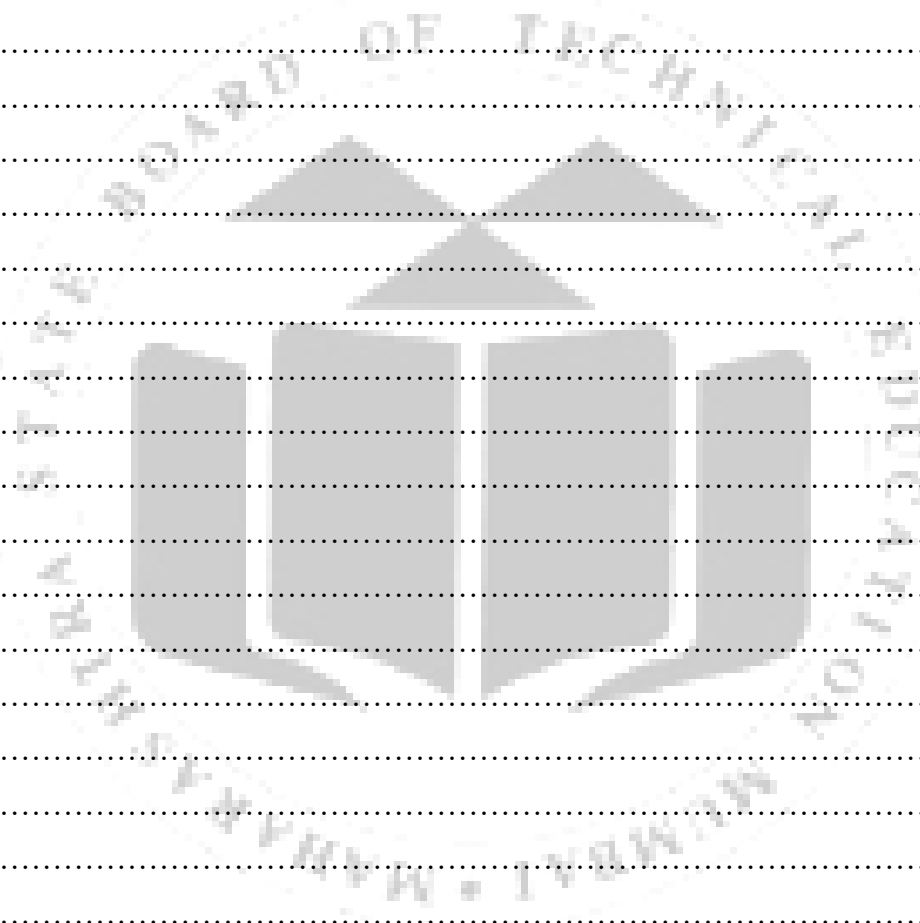

XIV References/Suggestions for further reading:

1. <https://www.mtu.edu/ehs/programs/electrical-safety/> assessed on 11th April, 2018.
2. <https://www.electrical4u.com/safety-precautions-for-electrical-system/>, assessed on 11th April, 2018.
3. <https://archive.org/details/gov.in.is.sp.30.2011.>, assessed on 11th April, 2018
4. <https://ia801005.us.archive.org/4/items/gov.in.is.5216.1.1982/is.5216.1.1982.pdf>, assessed on 11th April, 2018
5. <https://deepakkumaryadav.in/silvesters-method-of-providing-artificial-respiration/>
6. [https://www.resuscitationjournal.com/article/S0300-9572\(07\)00168-2/abstract](https://www.resuscitationjournal.com/article/S0300-9572(07)00168-2/abstract)

Assessment Scheme:

Performance Indicators		Weightage
Process Related: (15 Marks)		60%
1	Handling of the components	10 %
2	Identification of component	20 %
3	Measuring value using suitable instrument	20 %
4	Working in team	10 %
Product Related: (10 Marks)		40%
5	Identify theoretical values of given component from datasheets	10 %
6	Interpretation of result	05 %
7	Conclusions	05 %
8	Practical related questions	15 %
9	Submitting the journal in time	05%
Total (25 Marks)		100 %

Marks Obtained			Dated signature of Teacher
Process Related (15)	Product Related (10)	Total (25)	

Practical No. 3: Measurement of earth resistance of electrical laboratory equipment.

I. Practical Significance:

Measurement of earth resistance ensures the safety and effectiveness of the earthing system by providing a low-resistance path for fault currents. It helps protect both personnel and equipment from electric shocks and voltage surges. Regular testing also ensures compliance with safety standards and aids in maintenance of electrical installations.

II. Industry/Employer Expected Outcome(s):

Understand the importance of a low-resistance earthing system for electrical safety. Measure and evaluate the earth resistance of laboratory equipment using standard testing methods.

Ensure the effectiveness of earthing systems to protect personnel and equipment from electrical faults and surges.

III. Course Level Learning Outcome(s):

CO1 - Follow safety norms to prevent accidents while using electrical equipment.

IV. Laboratory Learning Outcome(s)

LLO 3.1 Measure earth resistance.

V. Relevant Affective Domain related outcome(s)

The student will demonstrate a responsible attitude toward maintaining safe and effective earthing practices in electrical installations.

VI. Relevant Theoretical Background (With diagrams if required)

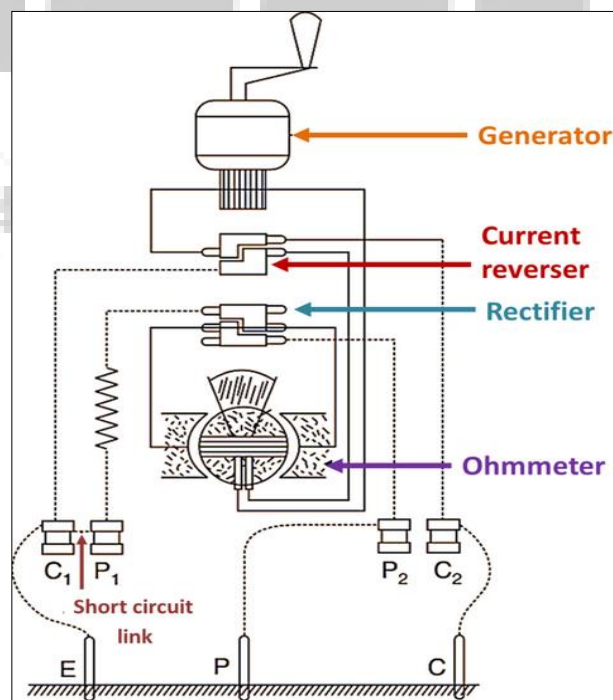

Fig.3.1 Earth Tester

Earth tester is an electrical measuring instrument used to measure resistance between any two points of the earth. It is also called as earth resistance tester.

Experimental set up details: Let's say that rod 1(E1,P1-Short) is our earth plate under test, rod (P2) potential-references and rod 3(E2) Current reference (simply for convenience in identification). As shown in Fig 3.2. The current flowing through rod 1(E1, P1-Short) and rod 3(E2) is I ; the potential difference between rod 1(E1, P1-Short) and rod 2 (P2) is V . If rod 2 (P2) is located at various point between rod 1 and rod 3, preferably in a straight line, you can get a series of voltage readings. By Ohm's Law ($R = V/I$) you can determine the earth resistance at any point measured. For example, if the measured voltage V between rod 1 and rod 2 is 6V and the measured current I is 400mA, the resistance of the earth R at that point would be 15Ω . In Example plot of Earth Resistance measured versus Distance (rod2 from rod1), series of resistance values are plotted against distance to obtain a curve. Note that as rod 2 (P2) is moved away from rod 1, the resistance values increase, but the amount of Increase gets less and less until a point is reached where the rate of increase becomes so small that I can almost be considered constant (20Ω). The earth shells between the two rods (1 and 2) have so great a surface area that they add little to the total resistance. Beyond this point, as rod 2 (P2) approaches the earth shells of rod 3(E2), resistance gradually picks up. Near rod 3(E2), the values rise sharply.



Fig. 3.2 Four Terminal Analog and Digital Earth Tester

VII. Actual Circuit diagram used in laboratory with equipment Specifications:

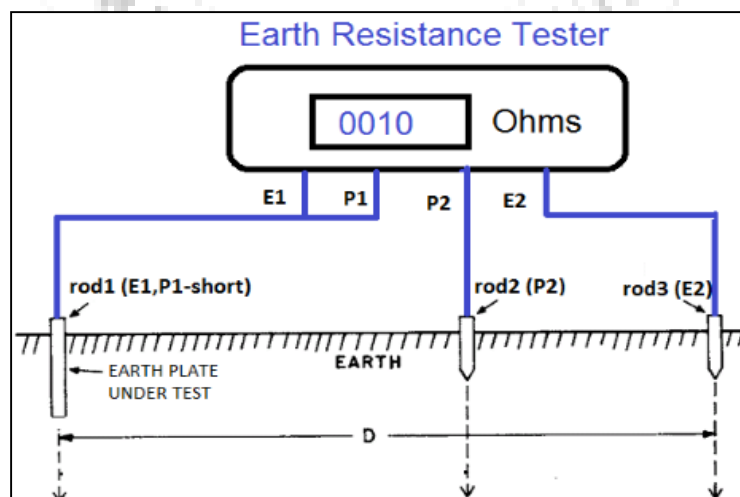

Fig. 3.3 Measurement of earth resistance

VIII. Required Resources / apparatus / equipment with specification:

Sr. No.	Name of Resource	Suggested Broad Specification	Quantity
1.	Earth Tester with connecting cables	Analog or Digital type	1 Set.
2.	Hammer ball peen	1 kg	1 No.
3.	Combination pliers	200mm	1 No.
4.	Screw driver	300mm	1 No.
5.	Earth Electrode (For Test)	As per standard	3 No.

IX. Precautions to be followed:

- Do not perform tests during storms or when lightning risk exists.
- Warn personnel and isolate the test area; keep people away from spikes and test leads.
- Disconnect the equipment from the supply (where possible) to avoid parallel earth paths affecting result and for safety. If testing on live systems, use clamp-on method per manufacturer instructions.
- Ensure no cables or metallic fencing connects to test area (these create parallel paths and inaccurate readings).
- Wear insulating gloves and shoes.
- Use correct lead connections (E, P, C) to avoid damaging the instrument.

X. Procedure:

1. To measure the earth resistance using an earth tester, a three-terminal type earth tester must be used.
2. Terminals **E1** and **P1** are shorted and connected to the equipment earth electrode whose resistance is to be measured (as shown in Fig. 3.3).
3. Disconnect the machine's earth conductor from the main bus.
4. Drive the **P2 (potential) rod** into the ground at a distance of 10–20 meters from the earth electrode.
5. Drive the **E2 (current) rod** into the ground at a distance of 30–40 meters from the earth electrode.
6. Make the connections as follows:
E → Equipment's earth point
P → Potential rod
C → Current rod
7. Start the test. The instrument will display the value of earth resistance.
8. Connect the terminals as per the experimental setup diagram and press the TEST switch to take the reading. Note the value displayed on the LCD of the instrument.
9. Tabulate the earth resistance readings versus distance (rod 2 from rod 1) in the observation table by varying the P2 rod between rod1 (E1, P1) and rod3 (E2) as per the figure.
10. Calculate the average of the constant readings obtained. This average value is considered as the Earth Resistance of the installation.

XI. Observations and calculations:

Name of Equipment:.....

Sr. No.	Distance Between Rod-1 (E1 and P1) and Rod-2 (P2) (m)	Distance Between Rod-1 and Rod-3 (E2) (m)	Earth Resistance Reading (Ω)	Average Earth Resistance (Ω)
01				
02				
03				
04				
05				

XII. Results:

.....
.....
.....
.....

XIII. Interpretation of results:

.....
.....
.....

XIV. Conclusion and recommendation

.....
.....
.....

XV. Practical related questions (Provide space for answers)

(Note: Below given are few sample questions for reference. Teachers must design more such questions so as to ensure the achievement of identified CO.)

1. State the methods of reducing resistance of earth electrode.
2. What will happen, if two earth electrodes are joined together?
3. What will be the effect of change in the speed of rotation of earth tester?
4. State the causes of higher value of earth resistance.
5. State the operating principle of analog earth tester

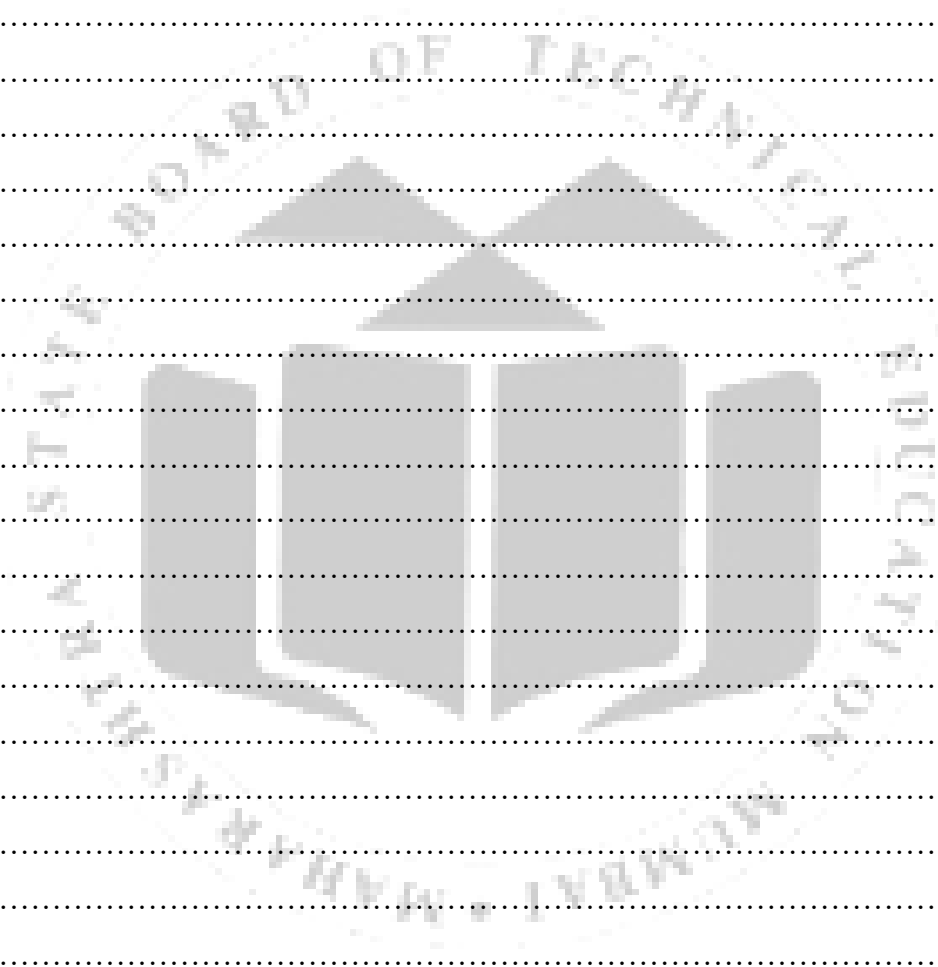

.....

.....

.....

.....

.....

.....

XVI. References/Suggestions for further reading:

1. <https://electricalworkbook.com/earth-tester/>
2. [https://www.vsmsrkit.edu.in/files/downloads/ec/1st_SEM_ELE_LAB_Manual\(18ELEL27\).pdf](https://www.vsmsrkit.edu.in/files/downloads/ec/1st_SEM_ELE_LAB_Manual(18ELEL27).pdf)

Assessment Scheme:

Performance Indicators		Weightage
Process Related: (15 Marks)		60%
1	Handling of the components	10 %
2	Identification of component	20 %
3	Measuring value using suitable instrument	20 %
4	Working in team	10 %
Product Related: (10 Marks)		40%
5	Identify theoretical values of given component from datasheets	10 %
6	Interpretation of result	05 %
7	Conclusions	05 %
8	Practical related questions	15 %
9	Submitting the journal in time	05%
Total (25 Marks)		100 %

Marks Obtained			Dated signature of Teacher
Process Related (15)	Product Related (10)	Total (25)	

Practical No. 4: Protective class of a given electric equipment.

I. Practical Significance:

In electrical engineering, protection class is used to classify and identify electrical equipment based on the type of protection provided against electric shock. Each class has its own symbol that is marked on the device to show how it is protected.

II. Industry/Employer Expected Outcome(s)

Able to identify and select electrical equipment based on its protection class, understand the type of electric shock protection it provides, and ensures the safe installation and operation of these devices in the workplace.

III. Course Level Learning Outcome(s)

CO1 - Follow safety norms to prevent accidents while using electrical equipment.

IV. Laboratory Learning Outcome(s)

LLO 4.1 Identify protective class of a given electric equipment.

V. Relevant Affective Domain related outcome(s)

To develop a safety-conscious attitude and demonstrate responsibility and care while selecting, handling, and operating electrical equipment to prevent electric shocks and workplace hazards.

VI. Relevant Theoretical Background (With diagrams if required)

IS/IEC 60529: 2001 — Degrees of Protection Provided by Enclosures (IP Code)
(Adopted from IEC 60529 international standard)

Basic Electrical Safety Concepts

- Understanding electric shock, current paths through the body, and hazards of live parts.
- Knowledge of insulation, earthing, and fault conditions.

Types of Protection Measures

- **Basic insulation:** Prevents direct contact with live parts.
- **Protective earthing (grounding):** Diverts fault current safely to earth.
- **Double or reinforced insulation:** Provides extra safety if one insulation layer fails.
- **Low voltage protection:** Using extra-low voltage (ELV) to avoid shock.

- **Protective Classes of Electrical Equipment**

1. **Class 0:** Only basic insulation, no earthing (obsolete).

Description

- Provides only basic insulation.
- No protective earth (no earthing conductor).
- If basic insulation fails → user is directly exposed to shock risk.
- Plug usually has only two pins.

Protection Method

- Only basic insulation (single layer).

Applications

- Rare today; not allowed in many countries.
- Old lamps, table fans, heaters (older models).

Safety Level **Very low** – Not acceptable for modern installations.

2. **Class I:** Basic insulation + protective earth.

Description

- Has basic insulation + protective earthing.
- All accessible metal parts are connected to earth.
- If insulation fails → fault current flows to earth → fuse/MCB trips.

Protection Method

- ✓ Basic insulation
- ✓ Protective earthing
- ✓ Automatic disconnection of supply (ADS) – fuse, MCB, RCCB

Identification

- Earth symbol (\perp)
- Plug has three pins (Phase, Neutral, Earth)

Applications

- Refrigerators
- Washing machines
- Electric irons
- Lab instruments with metal enclosures

Safety Level High (when earthing is proper)

3. **Class II:** Double/reinforced insulation, no earth.

Description

- Also called Double Insulated equipment.
- Does not rely on earthing.
- Accessible parts are normally non-metallic.
- Provides double or reinforced insulation inside.

Protection Method

- ✓ Basic insulation
- ✓ Supplementary insulation (second layer) OR ✓ Reinforced insulation

Identification

- Symbol of double-square (\boxplus)

Applications

- Mobile chargers
- Mixers & grinders

- Hair dryers
- Drills and hand tools
- LED drivers

Safety Level

Very high, even without earth

4. Class III: Operates on extra-low voltage (ELV), inherently safe.

Description

- Operates at Safety Extra Low Voltage (SELV).
- Typically, below:
 - 50V AC
 - 120V DC
- No risk of harmful shock because voltage is too low.

Protection Method

- ✓ Powered by SELV transformer or DC supply
- ✓ No exposed mains voltage

Identification

- SELV symbol
- Labels like "Low Voltage", "Class III"

Applications

- Toys
- Battery-operated tools
- LED strip lights (12V/24V)
- TV remotes
- Medical patient-connected devices (certain models)

Safety Level Very safe (no dangerous voltage present)

Protective Class	Description	Typical Equipment Examples	Key Identification Features
Class I (Earthed)	Safety provided by basic insulation + protective earth.	• Motors with metal body (induction motors) • Refrigerators • Washing machines • Electric heaters (metal body) • Desktop computers • Ovens, • Industrial machines	• Earth terminal symbol • Green-yellow earth wire in cable • Low resistance between earth & metal body
Class II (Double Insulated)	No earth; uses double or reinforced insulation.	• Hand drills, grinders, portable power tools • Mixers, blenders • Phone chargers • TV, LED lights (plastic body) • Hair dryers (plastic body)	• Double-square symbol • No earth pin/wire • Plastic external body • Very high insulation resistance
Class III (SELV – Safety Extra Low Voltage)	Powered by extra-low voltage , not connected directly to mains.	• Battery-operated devices • LED strip lights (12 V/24 V) • Mobile phones (powered by 5 V USB) • Low-voltage control circuits • Portable sensors, toys	• Rated voltage <50 V AC or <120 V DC • SELV/PELV markings • Supply via isolated transformer or adapter
Class 0 (not used in many countries)	Only basic insulation, no earth. Unsafe; mostly discontinued.	• Very old lamps or appliances (legacy)	• No earth, no double insulation, basic insulation only

VII. Actual circuit diagram used in laboratory with equipment specifications.

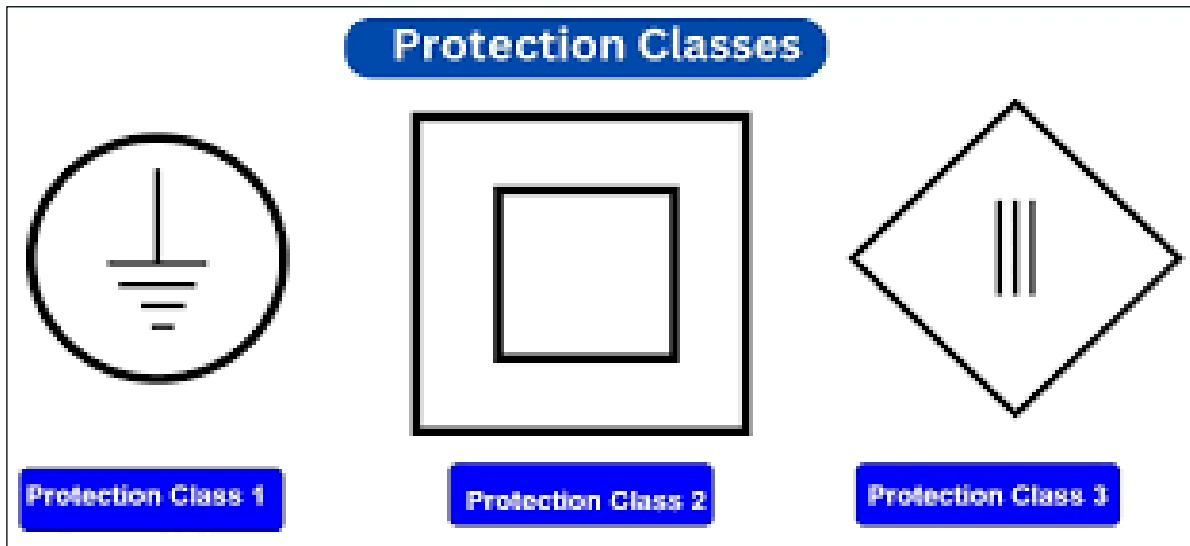

Figure 4.1 Symbol of Protection of classes

VIII. Required Resources/apparatus/equipment with specification:

Sr. No.	Name of Resource	Suggested Broad Specification	Quantity
1	Laboratory electrical equipment	IS 2992, IEC 61557-2, or equivalent international standards	1 No.
2	Continuity tester	As per standard	1 No.
3	Screwdrivers or opening tools (for safe inspection of covers)	-	1 Set
4	Electrical equipment/wiring installation/motor	As per available	-

IX. Precautions to be followed:

- Do not guess the protection class based on appearance alone.
- Make a note of the symbols on the device (Class I, II, III) for reference.
- Keep a safe distance from live terminals if power must be temporarily applied.

X. Procedure:

1. Check the plug type to see whether the equipment has a 3-pin (earthed) or 2-pin (unearthed) connection.
2. Examine the nameplate or label for protection class markings or double-insulation symbols.
3. Observe the construction of the equipment to identify whether it has a metal body (Class I) or fully insulated body (Class II).
4. Verify if the equipment operates on low-voltage (SELV) supply, indicating Class III protection.

XI. Observations:

(Identify the protection class of the electrical equipment's present in your laboratory.)

Sr. No.	Name of Equipment	Protection class
1		
2		
3		
4		

XII. Results:

.....
.....
.....
.....

XIII. Interpretation of results:

.....
.....
.....
.....

XIV. Conclusion and recommendation

.....
.....
.....
.....

XV. Practical related questions (Provide space for answers)

(Note: Below given are few sample questions for reference. Teachers must design more such questions so as to ensure the achievement of identified CO.)

1. What is meant by the protective class of electrical equipment?
2. Why is it important to classify electrical equipment based on protective class?
3. How does the protective class affect the safety of the user?
4. What is the difference between Class I and Class II equipment?
5. Give examples of Class I, Class II, and Class III electrical appliances.

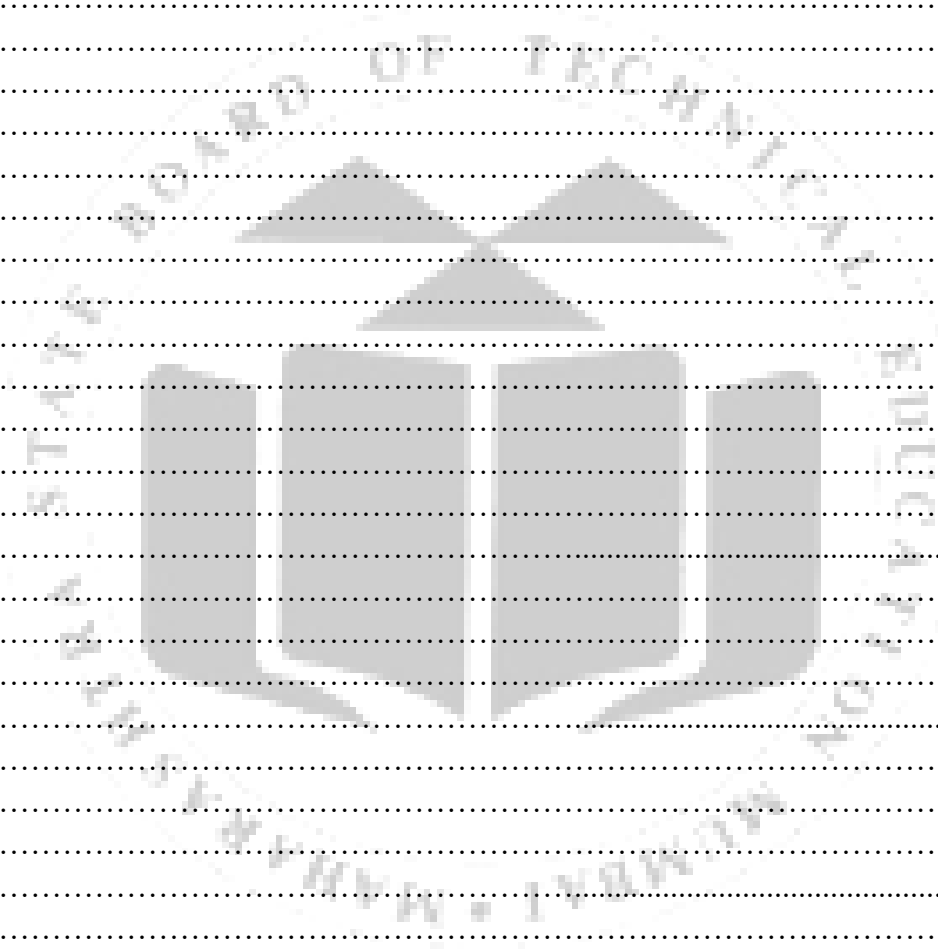

XVI. References/Suggestions for further reading:

1. <https://www.iec.ch/ip-ratings>
2. <https://www.fatshackvintage.com.au/pages/ip-ratings?srsltid=AfmBOoqlG1NUqBxrhJsJk3Muu-30xzwZjNPwrL96pOyofL0FotSuaBRb>
3. <https://www.tme.com/in/en/news/library-articles/page/21595/ip-international-protection-or-ingress-protection-and-ik-impact-protection-ratings/#klasa-szczelnosci>
4. https://www.instrumart.com/assets/Megger-Guide-to-Insulation-Testing.pdf?srsltid=AfmBOorfWzRzJfTfXBDw9tUdGX1VVE3_qeop0phEddymJ55VBySknwm
5. <https://www.electricalvolt.com/protection-classes-class-0-class-1-class-2-and-class-3/>

Assessment Scheme:

Performance Indicators		Weightage
Process Related: (15 Marks)		60%
1	Handling of the components	10 %
2	Identification of component	20 %
3	Measuring value using suitable instrument	20 %
4	Working in team	10 %
Product Related: (10 Marks)		40%
5	Identify theoretical values of given component from datasheets	10 %
6	Interpretation of result	05 %
7	Conclusions	05 %
8	Practical related questions	15 %
9	Submitting the journal in time	05%
Total (25 Marks)		100 %

Marks Obtained			Dated signature of Teacher
Process Related (15)	Product Related (10)	Total (25)	

Practical No. 5: Visit BIS portal (bis.gov.in) for getting ISI mark/obtaining a license for Electrical equipment's and prepare a report for it.

I. Practical Significance:

The BIS (Bureau of Indian Standards) portal (bis.gov.in) enables manufacturers to apply online for ISI certification a mandatory mark ensuring safety, reliability, and quality of electrical equipment sold in India.

II. Industry/Employer Expected Outcome(s):

- Understand BIS certification procedures and safety standards for electrical products.
- Apply regulatory compliance to ensure product quality and reliability.
- Support organizations in meeting legal and market requirements.
- Enhance product credibility, consumer trust, and competitiveness in both domestic and global markets.

III. Course Level Learning Outcome(s):

CO1 - Follow safety norms to prevent accidents while using electrical equipment.

IV. Laboratory Learning Outcome(s):

LLO 5.1 Get acquainted with the procedure for getting ISI mark.

V. Relevant Affective Domain related outcome(s):

Students develop a sense of responsibility and appreciation for adhering to national quality and safety standards. They show interest in regulatory compliance, value ethical manufacturing practices, and demonstrate a positive attitude toward ensuring consumer safety and product reliability through BIS certification.

VI. Relevant Theoretical Background (With diagrams if required):

The Bureau of Indian Standards (BIS) is the national body responsible for formulating and implementing quality standards for products in India. The ISI mark indicates that a product conforms to the relevant Indian Standard, ensuring safety, reliability, and performance. Understanding the BIS certification process involves knowledge of product testing, quality management systems, and regulatory compliance procedures. Students should also be familiar with the concept of compulsory registration schemes (CRS), standardization process, and the importance of certification in maintaining consumer trust and preventing substandard electrical equipment in the market.

The Indian Standards Institution (ISI) was established on January 6, 1947, just before India's independence, to develop and promote national standards for products, ensuring quality and uniformity across industries. Its creation addressed the urgent need for industrial standardization and quality control in newly industrializing India.

In 1952, ISI gained legal authority through the Indian Standards Institution (Certification Marks) Act, which enabled it to certify products that met Indian Standards. The ISI Mark was officially introduced in 1955–56, allowing manufacturers to display it on products conforming to national standards, thereby assuring consumers of quality and safety.

To strengthen quality infrastructure, ISI established its own central laboratory in 1963.

Recognizing the need for a more empowered statutory body, the Government of India enacted the Bureau of Indian Standards (BIS) Act in 1986, which came into effect on April 1, 1987. The newly formed BIS took over the functions, assets, and personnel of ISI and expanded its role to include certification, standard formulation, consumer protection, and quality assurance.



Fig 5.1. BIS Registration

Today, BIS serves as India’s national standards body, formulating Indian Standards, issuing ISI and Hallmark certifications, accrediting laboratories, and ensuring safe, reliable, and high-quality products across industrial and consumer sectors.

VII. Required Resources/apparatus/equipment with specification:

1. Digital and Documentation Resources

Sr. No.	Name of Resource	Suggested Broad Specification	Quantity
1	Computer or Laptop	Internet-enabled, minimum 8GB RAM, updated browser support (Chrome/Edge)	1 No
2	Internet Connection	Minimum speed: 2 Mbps stable broadband or Wi-Fi	1 Set
3	BIS Portal Access (https://www.bis.gov.in)	Valid user registration credentials (email ID, password)	-
4	Printer/Scanner	Standard A4 printing/scanning for documents	1 No.

2. Documentation and Application Materials

Sr. No.	Name of Resource	Suggested Broad Specification	Requirement
1	Product Standard Reference	Relevant Indian Standard (IS code) for the electrical item (e.g., IS 694 for PVC cables, IS 302 for appliances)	Identifies applicable BIS certification
2	Test Reports	Laboratory test report from a BIS-recognized lab confirming compliance with IS standards	To verify product safety and quality

3	Factory Registration Certificate	Valid business registration or MSME certificate	Confirms manufacturer eligibility for BIS licensing
4	Factory Layout Diagram	Technical factory layout showing production and testing facilities	Submitted with the online application
5	Quality Control Plan	Internal testing and quality checks documentation	Demonstrates in-house conformity assessment capability
6	Trademark Registration Proof	Registered brand or trademark under which product is sold	Ensures product identity authenticity

3. Testing and Inspection Apparatus

Sr. No.	Equipment	Specifications	Use
1	Electrical Testing Setup	Standard BIS-calibrated meters (insulation tester, continuity tester, voltage meter)	To validate safety and performance parameters during factory inspection
2	BIS-Recognized Testing Laboratory Facilities	NABL-accredited labs equipped for thermal, insulation, and durability testing	Used to perform sample testing as part of BIS certification

VIII. Precautions to be followed:

1. Collect accurate product details and IS standards before visiting the portal to prevent selecting the wrong certification category.
2. Always use official BIS portals (bis.gov.in / manakonline.in) only; avoid third-party or fake sites mimicking BIS platforms.
3. Respond promptly to any BIS clarification or inspection queries to maintain smooth progress.
4. Maintain confidentiality of your login credentials to prevent unauthorized access to your application data.
5. Ensure timely renewal of licenses before expiry to avoid suspension of the ISI mark.

IX. Procedure:

1. Identify Applicable Indian Standard (IS)

- Visit the BIS official website (www.bis.gov.in) and refer to the “Product Certification” section.
- Determine if the electrical product (like cables, motors, fans, or household appliances) is covered under mandatory BIS certification through Quality Control Orders (QCOs).

- Note the relevant Indian Standard (IS) code applicable to your product (e.g., IS 694 for PVC cables, IS 985 for fans).

2. Prepare Necessary Documentation

Gather and organize all required information before applying online:

- Factory or manufacturing unit registration certificate.
- Product specifications, drawings, and Bill of Materials (BoM).
- Test reports from BIS-recognized laboratories.
- Manufacturing process details and Quality Control Plan (QCP).
- Factory layout, photos, and machinery details.
- Trademark registration, authorization letters, and declarations.

3. Create Account and Submit Online Application

- Register on the BIS “Manak Online Portal” (<https://manakonline.in>).
- Select Scheme-I (ISI Mark) for domestic product certification.
- Fill Form-V with factory address, product category, and the relevant IS standard.
- Upload the compiled documents and pay the prescribed application fee online.

4. Product Testing and Factory Audit

- BIS officials may:
 - Draw product samples and send them to BIS-recognized laboratories for testing.
 - Conduct a Preliminary Factory Inspection (PFI) to verify quality control, production, calibration, and traceability systems.
 - Test results must comply with the Indian Standard benchmarks; any non-conformity must be rectified through Corrective and Preventive Action (CAPA) documentation.

5. Technical Evaluation by BIS

- The BIS technical committee examines application data, test results, and factory audit reports.
- The applicant may be required to submit clarifications or supplementary documents if discrepancies are found.

6. Grant of License (ISI Mark)

- If the product meets all requirements, BIS issues a license (CM/L number) allowing the manufacturer to use the ISI Standard Mark on the product and packaging.
- The license is valid for two years and renewable upon continued compliance.

7. Post-License Obligations

- The license holder must:
 - Pay marking and renewal fees as per BIS norms.
 - Facilitate annual surveillance audits by BIS officers.
 - Maintain test records and ensure continued conformity with the applicable IS standard.

Example for getting ISI mark for the ceiling fan

Indian Standard: IS 374:2019 — Electric Ceiling Type Fans — Specification

- Fan size and air delivery performance
- Input power efficiency
- Electrical insulation and high-voltage safety
- Resistance to heat, fire, and corrosion
- Mechanical integrity and vibration limits.

Required Documents:

Manufacturers must submit the following documents to BIS:

- Factory registration certificate and ownership proof
- Product specifications (model numbers, fan size, power rating)
- Test reports from a BIS-recognized laboratory
- Factory layout and equipment list
- Quality control manual and calibration record
- Details of quality control personnel
- Trademark and brand authorization certificates.

X. Observations and calculations:

Product 01: -Cost & Time frame

Product Name: - Electrical Ceiling Fans

Item	Approximate Fees in INR	Remarks
Application Fee	1000	Paid to BIS
Audit Fee	7000	For factory inspection
Testing Fee	As applicable	Depends on lab and fan model
License Fee	1000	Payable to BIS

Product 02: -Cost & Time frame

Product Name: _____

Item	Approximate Fees in INR	Remarks

XI. Results:

.....

.....

.....

.....

XV. References/Suggestions for further reading:

1. www.bis.gov.in
2. https://www.sunren.net/blog/bis-certification-india/#How_to_Get_BIS_certification_in_India_Step-by-Step_Process
3. <https://www.agileregulatory.com/service/bureau-of-indian-standard-bis-registration>
4. <https://alephindia.in/isi-product/electric-ceiling-type-fans.php>
5. <https://www.britannica.com/topic/Bureau-of-Indian-Standards>
6. <https://www.iso.org/member/1794.html>

Assessment Scheme:

Performance Indicators		Weightage
Process Related: (15 Marks)		60%
1	Handling of the components	10 %
2	Identification of component	20 %
3	Measuring value using suitable instrument	20 %
4	Working in team	10 %
Product Related: (10 Marks)		40%
5	Identify theoretical values of given component from datasheets	10 %
6	Interpretation of result	05 %
7	Conclusions	05 %
8	Practical related questions	15 %
9	Submitting the journal in time	05%
Total (25 Marks)		100 %

Marks Obtained			Dated signature of Teacher
Process Related (15)	Product Related (10)	Total (25)	

Practical No. 6: Dismantle and reassemble the given electrical machine and identify the various parts

I. Practical Significance:

Three-phase induction motors are widely used in industries as drive motors for a variety of machines due to their rugged construction, smooth and efficient operation, affordability, ease of maintenance, and high reliability. These motors operate at nearly constant speed from no-load to full-load conditions. However, their speed is dependent on the supply frequency, which makes precise speed control somewhat challenging. A three-phase induction motor can be employed for different applications with varying load requirements. Its construction is relatively simple, comprising two main parts: the stator and the rotor.

II. Industry/Employer Expected Outcome(s)

- Dismantle and reassemble a three-phase induction motor safely and systematically.
- Identify and describe the function of various motor parts, including the stator, rotor, bearings, shaft, end shields, and cooling fan.
- Understand assembly tolerances and alignment requirements to ensure proper motor operation.
- Develop practical skills relevant to maintenance, troubleshooting, and repair of industrial induction motors.

III. Course Level Learning Outcome(s)

CO2 - Test electrical equipment.

IV. Laboratory Learning Outcome(s)

LLO 6.1 Use tools/accessories applicable in the process.

LLO 6.2 Identify the parts of a given motor.

V. Relevant Affective Domain related outcome(s)

Demonstrates care, responsibility, and safety while dismantling and reassembling electrical machines, with attentiveness and patience.

VI. Relevant Theoretical Background (With diagrams if required)

A 3-phase induction motor works on the principle of electromagnetic induction — when a 3-phase supply is given to the stator winding, a rotating magnetic field (RMF) is produced, which induces an EMF in the rotor conductors. The rotor currents interact with the stator field to produce torque, causing rotation.

A typical electric motor has two main parts: the stator and the rotor. The stator usually includes a frame, core, and windings, while the rotor is the part that rotates and may have windings or magnets. Other parts, like bearings, brushes, and a commutator, may also be present depending on the type of motor.

Main Parts of Induction Motor:

- **Stator:** Stationary part that produces a rotating magnetic field.
- **Rotor:** Rotating part placed inside the stator.

- **Shaft:** Transmits mechanical output.
- **Bearings:** Support the rotor and reduce friction.
- **End Shields / End Covers:** Hold the bearings and protect internal parts.
- **Cooling Fan:** Provides cooling to the motor.
- **Frame / Casing:** Encloses all parts and provides mechanical strength.

Types of Rotors:

- **Squirrel Cage Rotor:**
Made of laminated iron core with aluminium or copper bars short-circuited by end rings. It is simple, rugged, and maintenance-free.

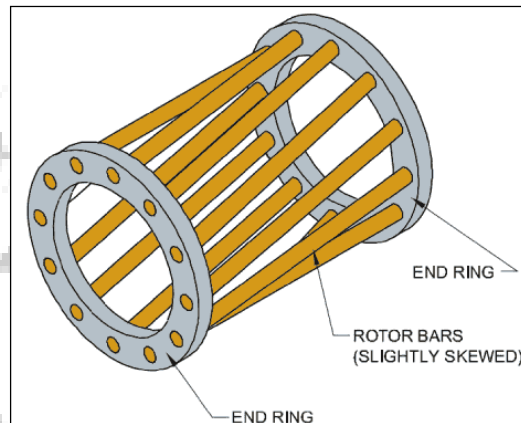

Fig.6.1 Squirrel cage rotor

- **Slip Ring Rotor (Wound Rotor):**
Has a 3-phase winding on the rotor connected to slip rings and external resistors through brushes. It allows external resistance control during starting and speed regulation.

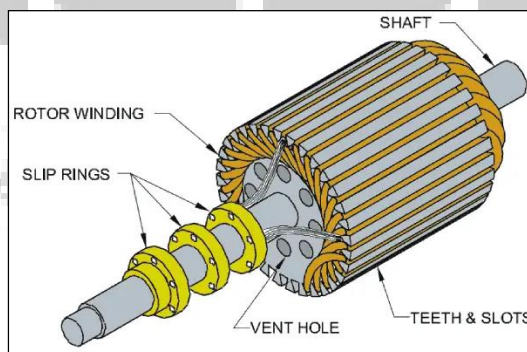

Fig.6.2 Slipring rotor (Wound Rotor)

Accessories / Safety Items

1. Work Gloves – For hand protection.
2. Safety Goggles – Protect eyes from debris.
3. Lubricating Oil / Grease – For bearings and moving parts during reassembly.
4. Cleaning Brush / Cloth – To clean dust and dirt from components.
5. Workbench with Vise / Clamps – To hold parts securely while working.
6. Labels / Tags – To mark parts for proper reassembly.

VII. Actual Circuit diagram used in laboratory with equipment Specifications:

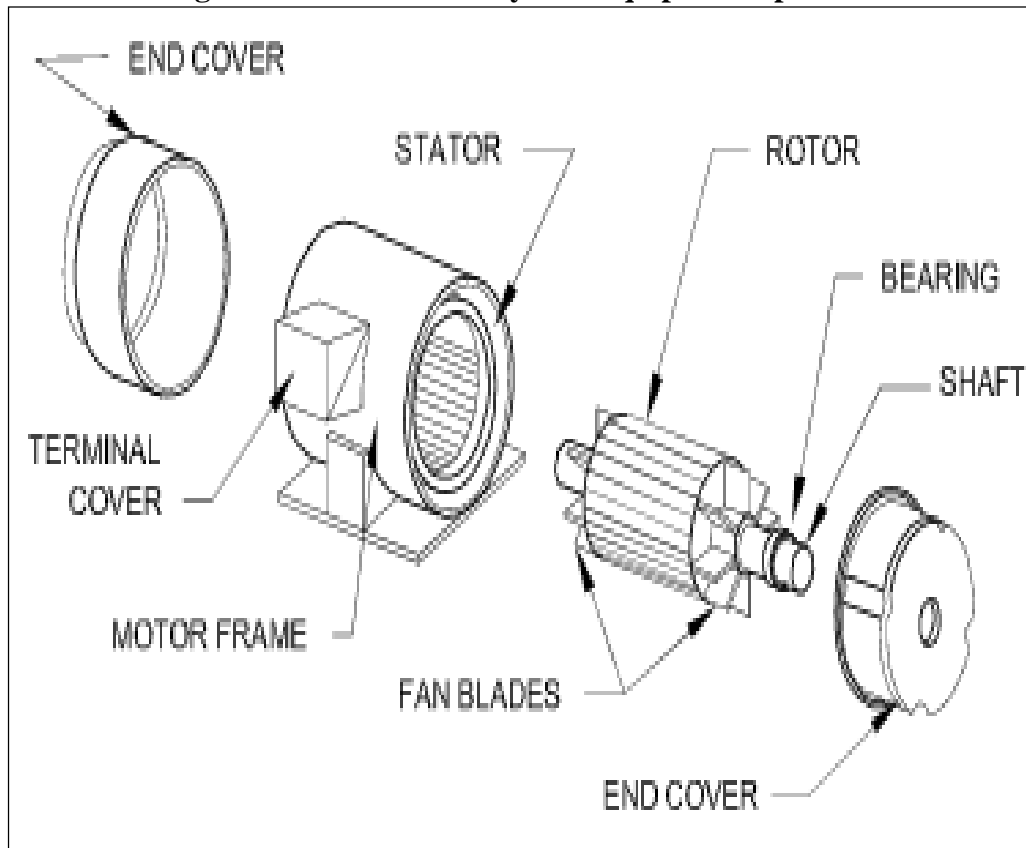

Fig.6.3- 3 Phase Squirrel Cage Induction motor

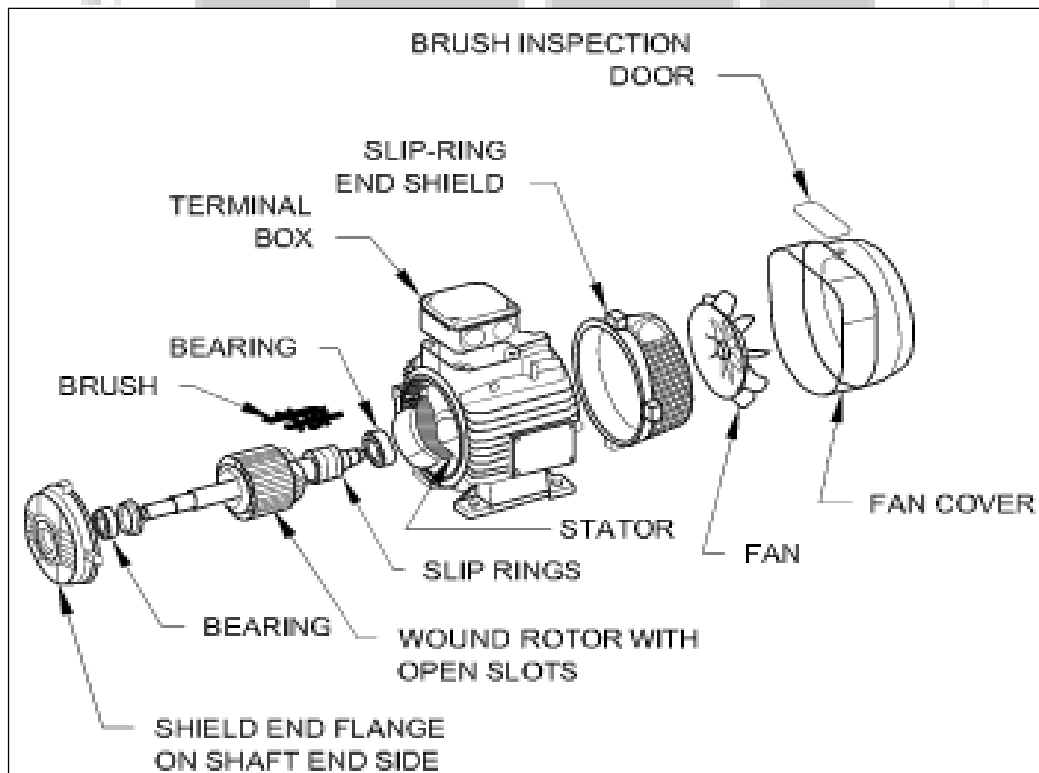

Fig.6.4-3 Phase Slip ring Induction motor

VIII. Required Resources/apparatus/equipment with specification:

Sr. No.	Name of Resource	Suggested Broad Specification	Quantity
1.	AC 3 phase squirrel cage induction motor	5HP, 3-Phase, 415V, 50Hz (As per availability)	01 No.
2.	Insulated screw driver	200mm with 4mm blade	02. No
3.	DE spanner set	5 mm to 20mm	1 Set
4.	MI volt meter	0-500 V	1 No.
5.	Test lamp	240V, 60 Watts	1 No.
6.	PVC Insulated copper cable	1.5 sq mm	2 Mtr
7.	Screwdrivers	Flathead and Phillips for removing screws	1 Set
8.	Spanners / Wrenches	Open-ended or ring spanners for bolts and nuts	1 Set
9.	Hammer / Rubber Mallet	Gentle tapping to loosen parts without damage.	1 No
10.	Bearing Puller / Gear Puller	To safely remove bearings or tight-fitting components.	1 No
11.	Pliers	Needle-nose and combination pliers for gripping and cutting wires.	1 No
12.	Measuring Tools	Vernier caliper or micrometer for checking dimensions of parts.	1 No
13.	Insulation Tester / Megger – Optional, to check windings after reassembly.	1000Volt	1 No

IX. Precautions to be followed:

- Ensure the machine is disconnected from the power supply before starting work.
- Use proper and insulated tools for dismantling and assembling.
- Always wear safety shoes, gloves, and goggles while handling the machine.
- Handle all parts carefully to avoid damage to the windings or mechanical components.
- Mark or label each part during dismantling to ensure correct reassembly.
- Avoid touching bare terminals or live wires to prevent electric shock.
- Keep the work area clean, dry, and organized.
- Do not use excessive force or hammering while removing or fitting parts.
- Take care not to damage the insulation on winding wires.
- Perform all work under instructor supervision and follow safety instructions.

X. Procedure

1. Read and interpret the name plate details of the 3 phase squirrel cage induction motor and note down in Table 6.1

Manufacturer, Trade Mark.....	
Type or model or	Rated power.....k.w/HP
Type of current.....	Rating class.....
Insulation class.....	Rated frequency.....Hz
Serial number.....	Rated current.....Amps
Type of connection.....	Rated speed.....r.p.m
Rated voltage.....	Volts Protection class.....

2. Identify the parts of the AC squirrel cage induction motor from the real objects or from the exploded view chart (fig.6.3/6.4)
3. Label the each identified parts with number tags.
4. Write the name of the parts of each labeled number tag in observation table.
5. Get it checked with your Course Teacher.

XI. Observations:

Sr. No.	Name of the Part	Material used	Function
1.			
2.			
3.			
4.			
5.			
6.			

XII. Results:

.....

.....

.....

.....

XVI. References/Suggestions for further reading:

1. https://www.mangoengineer.in/2024/02/squirrel-cage-induction-motor.html#google_vignette
2. <https://studyelectrical.com/2014/11/how-three-phase-induction-motor-work.html>

Assessment Scheme:

Performance Indicators		Weightage
Process Related: (15 Marks)		60%
1	Handling of the components	10 %
2	Identification of component	20 %
3	Measuring value using suitable instrument	20 %
4	Working in team	10 %
Product Related: (10 Marks)		40%
5	Identify theoretical values of given component from datasheets	10 %
6	Interpretation of result	05 %
7	Conclusions	05 %
8	Practical related questions	15 %
9	Submitting the journal in time	05%
Total (25 Marks)		100 %

Marks Obtained			Dated signature of Teacher
Process Related (15)	Product Related (10)	Total (25)	

Practical No. 7: Use of instruments for testing/maintenance of given electrical equipment

I. Practical Significance:

Practical helps students learn to use testing instruments like bearing puller, filler gauge, dial indicator, spirit level, growler, Earth tester, multimeters, meggers, and clamp meters to check, maintain, and ensure the safe operation of electrical equipment. It builds practical skills and confidence in fault detection and maintenance.

II. Industry/Employer Expected Outcome(s):

- Able to accurately test, diagnose, and maintain electrical equipment using standard testing instruments as per industrial safety practices.
- Demonstrates professionalism through precision, safety awareness, and proper documentation of maintenance activities.

III. Course Level Learning Outcome(s):

CO2 - Test electrical equipment.

IV. Laboratory Learning Outcome(s):

LLO 7.1 Use testing instrument for testing electrical equipment.

V. Relevant Affective Domain related outcome(s):

Shows accuracy, discipline, and teamwork during testing and maintenance activities.

VI. Relevant Theoretical Background (With diagrams if required):

- **Basic Electrical Knowledge:** Understanding of voltage, current, resistance, and Ohm's law.
- **Electrical Equipment Fundamentals:** Construction, working, and ratings of motors, transformers, and other electrical devices.
- **Instrument Principles:** Working and measurement methods of multimeter, megger, earth tester, growler, and test lamps.
- **Mechanical Tools Knowledge:** Purpose and correct use of bearing puller, filler gauge, dial indicator, spirit level, spanner sets, and screwdrivers.
- **Safety Practices:** Precautions while handling electrical equipment and mechanical tools.
- **Maintenance Concepts:** Basics of preventive and corrective maintenance for electrical devices.

Types of tools used for repairs, maintenance and troubleshooting.

Before performing maintenance, repairs, or troubleshooting on electrical machines, students should understand common faults such as winding failures, bearing issues, and insulation breakdowns, and how various tools and instruments help detect them. They should be familiar with testing procedures using instruments like megger, growler, and earth tester, as well as alignment and assembly techniques for rotors, stators, and bearings to ensure proper functioning. Knowledge of torque and tightening specifications for machine fasteners and connections is essential, along with an understanding of how measurements and adjustments, such as air gap and shaft alignment, affect the machine's performance and lifespan.

Instruments/Tools use for testing and maintenance of electrical machines and equipment's

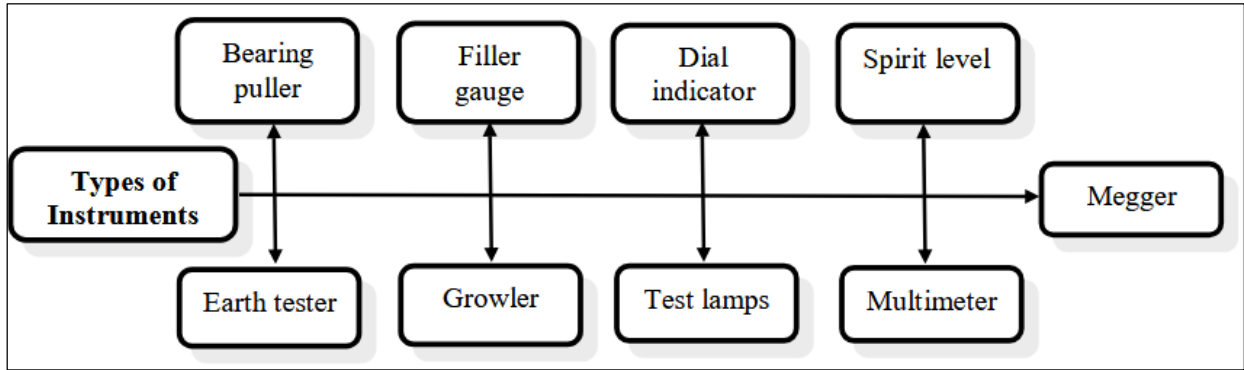

Fig.7.1 Types of Instruments

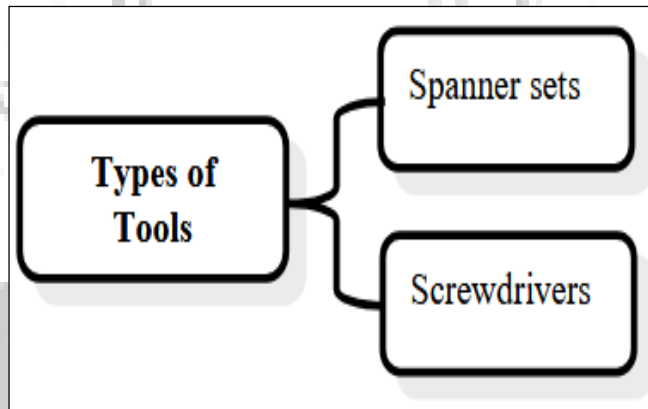

Fig. 7.2 Types of tools

VII. Actual Circuit diagram used with equipment Specifications:

1. Bearing puller

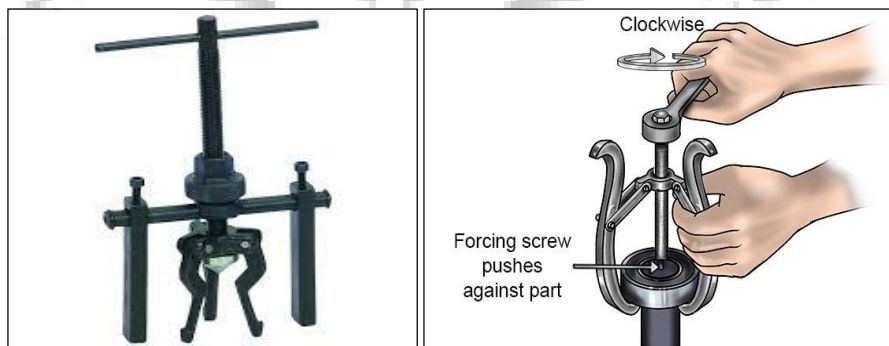

Fig. 7.3 Bearing Puller

Bearing puller is very necessary tool for repairs of machines for taking out the damaged bearing and put a new bearing on the shaft. It is also useful for withdrawing sprockets, gears when the space at the back is limited.

2. Filler Gauge

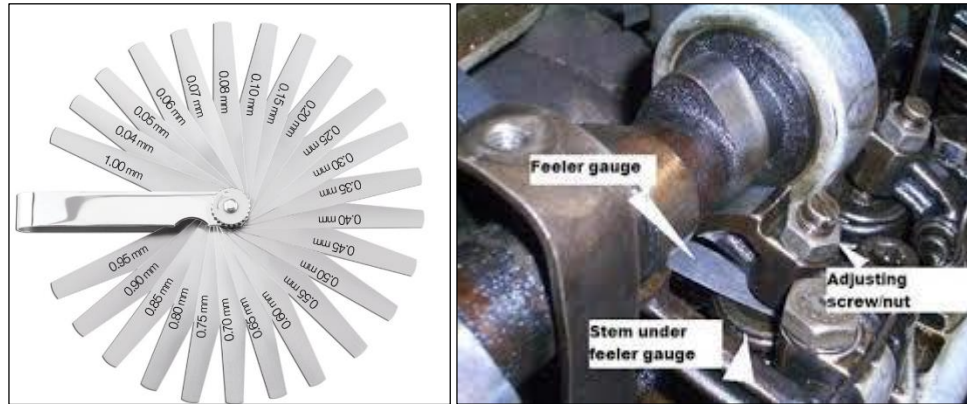

Fig. 7.4 Filler Gauge

A feeler gauge is a tool used to measure gap widths. Feeler gauges are mostly used in engineering to measure clearance between two parts such as air gap between stator and rotor. They consist of number of small lengths of steel of different thickness with measurements marked on each piece. They are flexible enough that, even if they are all on the same hinge, several can be stacked together to gauge intermediate values.

3. Dial Indicator

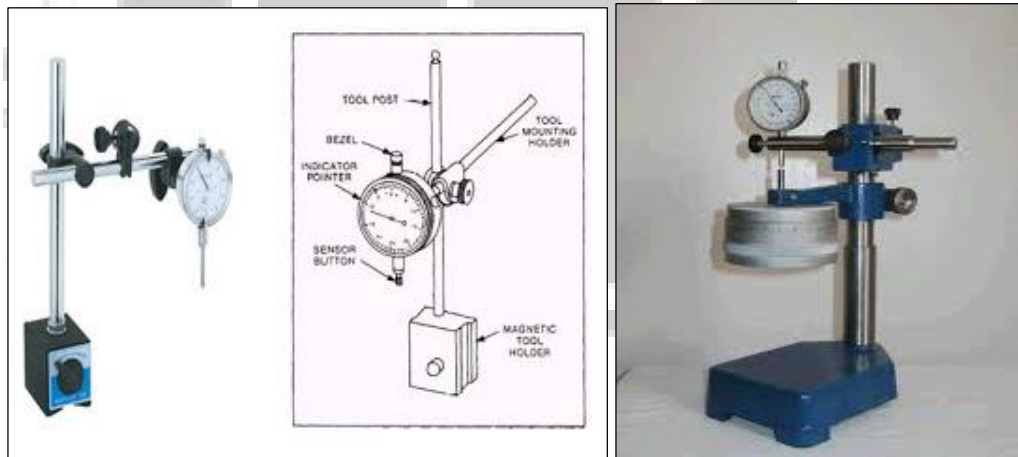

Fig. 7.5 Dial Indicator

The shape of various rotating parts of machine such as rotor, commutator is checked with the help of Dial test indicator. It consists of interlink liver and gear assembly. It accurately measures small distances and angles and amplify them to make them more obvious.

4. Spirit Level

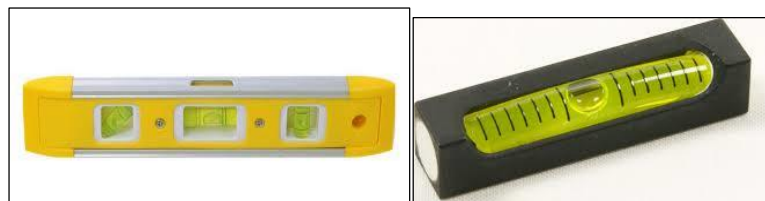

Fig. 7.6 Spirit Level

Spirit level is an instrument designed to indicate whether a surface or machine foundation is horizontal or not. Spirit level has curved glass tube. The tube is completely filled with a liquid,

usually a colored spirit or alcohol, leaving a bubble in the tube. The tube has upward curve, so that the bubble naturally rests in the centre, the highest point. Alcohol such as ethanol is often used because it has low viscosity and surface tension, which allows the bubble to travel the tube quickly and settle accurately with minimal interference with the glass surface.

When installing electrical machines, checking of foundation for correct level is necessary to avoid vibrations due to which bearings and shaft may get damaged

5. Megger

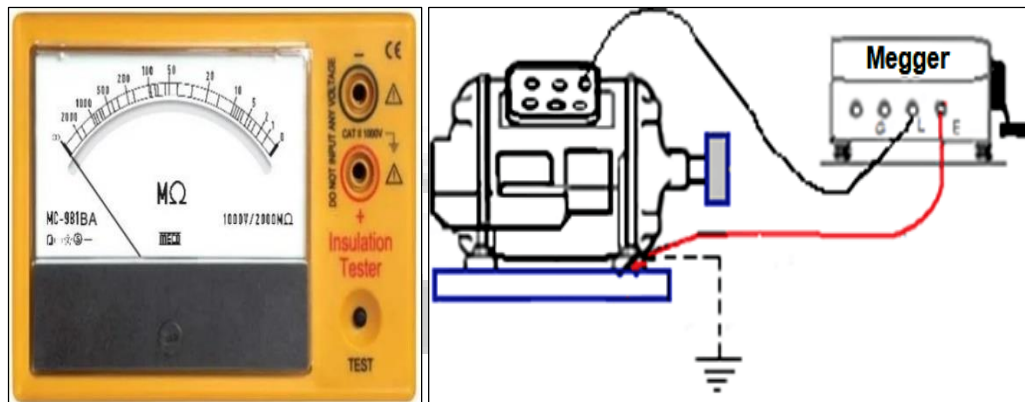

Fig. 7.7 Megger

A Megger (Insulation Resistance Tester) is used to check the insulation quality of electrical equipment and windings in motors, transformers, and cables. By applying a high DC voltage, it measures the resistance offered by the insulation between conductors or between a conductor and earth. Proper insulation ensures safe operation, prevents leakage currents, avoids short circuits, and prolongs the life of electrical machines. Regular megger testing helps in detecting deterioration, moisture ingress, or insulation breakdown before serious faults occur.

6. Multimeter



Fig. 7.8 Multimeter

A multimeter is used to measure voltage, current, and resistance in electrical equipment and windings. It helps in checking the continuity of circuits, verifying proper connections, and detecting open or shorted windings in motors and transformers. By providing accurate electrical measurements, the multimeter ensures that the equipment is operating safely and efficiently, and assists in troubleshooting faults during maintenance.

7. Test Lamp:



Fig. 7.9 Test Lamp

A test lamp is used to quickly check for the presence of voltage and the continuity of circuits in electrical equipment and windings. It helps in identifying live circuits, open connections, or blown fuses during maintenance. Test lamps are simple, portable, and provide a visual indication of electrical faults, making them useful for quick troubleshooting and safety checks.

8. Growler

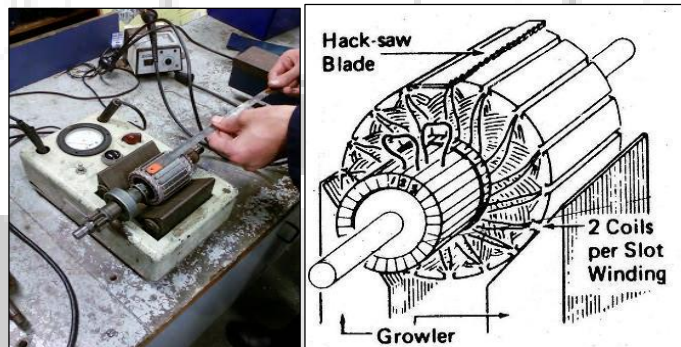

Fig. 7.10 Growler

It is a equipment used for finding out shorted turns of stator, rotor and armature winding. It is nothing but a single winding transformer. Low voltage or 230V A.C. supply is given to growler's winding. The winding acts as a primary winding.

The armature winding to be tested is put on Growler and armature is rotated with low speed. When the shorted coil comes under the influence of Growler's coil, it acts as a short-circuited secondary of transformer and hence very large current flows through shorted coil of armature. When very thin strip of iron is put on the armature slot containing shorted coil, it starts vibrating which gives indication of shorted coil.

9. Earth Tester:



Fig. 7.11 Earth Tester

An Earth Tester is used to measure the resistance of the earth/ground connection in electrical equipment and installations. Proper grounding ensures safety by providing a low-resistance path

for fault currents, preventing electric shocks, equipment damage, and fire hazards. Regular testing with an earth tester helps verify that the earthing system is effective and that electrical machines and installations operate safely.

VIII. Required Resources/apparatus/equipment with specification:

Sr. No.	Name of Resource	Suggested Broad Specification	Quantity
1.	Bearing puller	Two-jaw or three-jaw puller	1 No.
2.	Filler Guage	Thickness range 0.02 mm to 1.0 mm	1 No.
3.	Dial Indicator	Measuring Range 0–10 mm Resolution -0.01 mm Dial Diameter-50–100 mm	1No.
4.	Spirit Level	200–600 mm (Box level, tubular level, or digital level)	1 No.
5.	Megger	1000 V	1 No.
6.	Multimeter	AC/DC 0-1000V/0-750V	1 No
7.	Test lamp	40W, 230 V AC, 50 Hz	1 No
8.	Growler	100-150W	1 No
9.	Earth Tester	0–10 Ω, 0–100 Ω, 0–1000 Ω	
10.	Spanner Set	As per standard	1 Set
11.	Screwdriver set	As per standard	1 Set

IX. Precautions to be followed:

- **Safety First:** Always wear appropriate personal protective equipment (PPE) such as insulated gloves, safety goggles, and safety shoes.
- **De-energize Equipment:** Ensure the machine or circuit is switched off and properly isolated before starting maintenance or using instruments.
- **Proper Tool Selection:** Use the correct tool or instrument for the specific task to avoid damage to equipment or injury.
- **Check Instrument Condition:** Verify that meters, testers, and other instruments are calibrated, undamaged, and functioning correctly.
- **Avoid Moisture:** Keep tools and instruments dry to prevent electrical shocks or inaccurate readings.
- **Handle Tools Carefully:** Use mechanical tools like bearing pullers, spanners, and screwdrivers properly to prevent injury and damage.
- **Follow Manufacturer Guidelines:** Always follow the instructions provided for instruments and equipment.
- **Secure Work Area:** Keep the workspace organized and free of loose wires or tools to avoid accidents.

- **Measure Correctly:** Connect measuring instruments in the correct polarity and range to prevent errors or damage.
- **Store Tools Properly:** After use, clean and store tools and instruments in their designated places to maintain longevity.

X. Procedure:

Preparation:

- Wear appropriate PPE (insulated gloves, safety goggles, safety shoes).
- Ensure the equipment is switched off and properly isolated from the power supply.
- Gather all required tools and instruments: multimeter, megger, earth tester, growler, test lamps, dial indicator, filler gauge, spirit level, bearing puller, spanner sets, and screwdrivers.

Inspection:

- Visually inspect the electrical machine for signs of damage, wear, or loose connections.
- Check mechanical components like bearings, shafts, and couplings for proper alignment and lubrication.

Mechanical Maintenance:

- Use tools like spanners, screwdrivers, bearing puller, dial indicator, filler gauge, and spirit level to dismantle, inspect, measure, and reassemble mechanical parts.
- Ensure proper alignment, correct air gaps, and tight assembly of all components.

Electrical Testing:

- Use a megger to check insulation resistance of windings.
- Use a multimeter to measure voltage, current, and resistance, and to check continuity.
- Use a test lamp to verify the presence of voltage and open circuits.
- Use a growler to detect shorted or open coils in armatures or stators.
- Use an earth tester to measure grounding resistance and ensure safety.

Documentation and Verification:

- Record all readings and observations for future reference.
- Verify that all electrical and mechanical parameters are within permissible limits.
- Reassemble the machine completely, ensuring all tools are removed, and perform a final check.

Safety Check:

- Switch on the equipment and monitor for abnormal sounds, vibrations, or readings.
- Ensure the equipment is operating safely and efficiently before leaving the site.

XI. Observations and calculations:

Sr. No.	Tools	Materials	Applications
1	Bearing Puller		
2	Feeler Gauge		
3	Dial test Indicator		
4	Spirit level		
5	Megger		
6	Multimeter		
7	Test Lamp		
8	Growler		
9	Earth Tester		

XII. Results:

.....

XIII. Interpretation of results:

.....

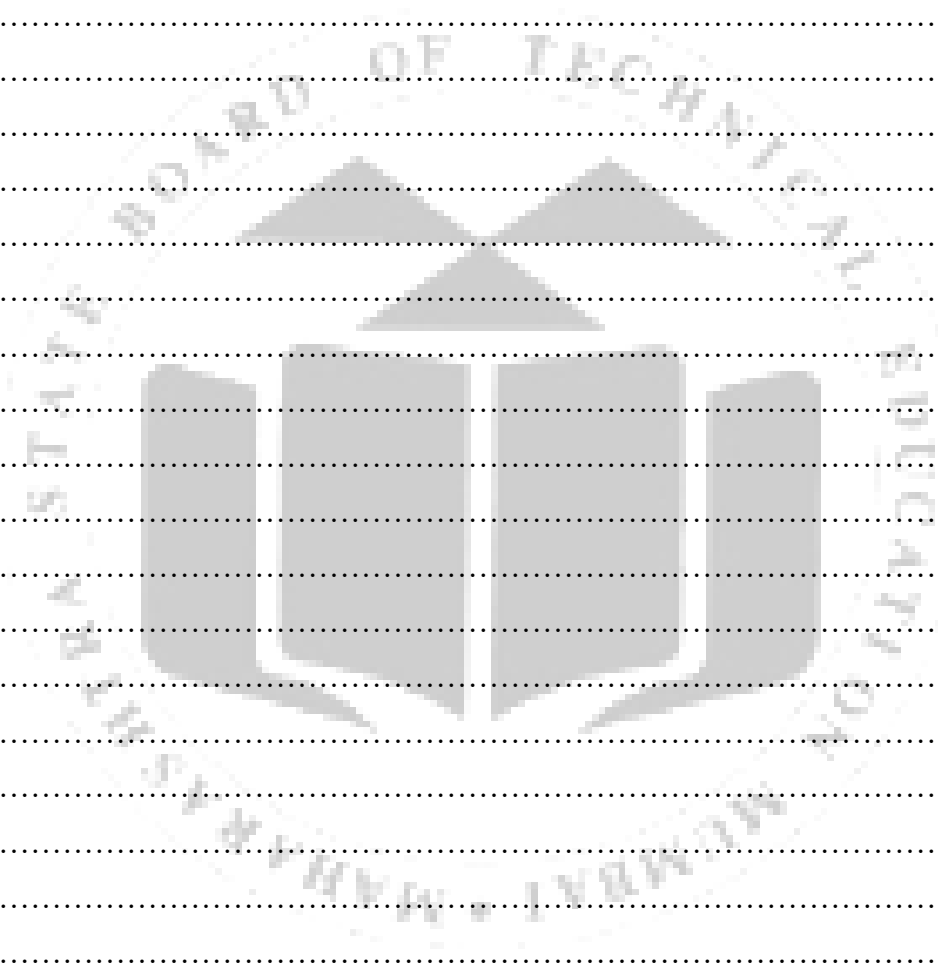

XVI. References/Suggestions for further reading:

1. <https://www.wonkeedonkeetools.co.uk/pulleys/how-to-use-a-bearing-puller>
2. https://www.meco.in/?gad_source=1&gad_campaignid=22735972212&gclid=CjwKCAjwmNLHBhA4EiwA3ts3mTNJeOAAApZQ19WBe0nymX0uiAFKjH6lgyXewmt_F0UoyxnV_PCzSBoCrxUQAvD_BwE
3. <https://instrumentationtools.com/how-to-test-a-motor-using-megger/>
4. <https://www.ubuy.co.in/>

Assessment Scheme:

Performance Indicators		Weightage
Process Related: (15 Marks)		60%
1	Handling of the components	10 %
2	Identification of component	20 %
3	Measuring value using suitable instrument	20 %
4	Working in team	10 %
Product Related: (10 Marks)		40%
5	Identify theoretical values of given component from datasheets	10 %
6	Interpretation of result	05 %
7	Conclusions	05 %
8	Practical related questions	15 %
9	Submitting the journal in time	05%
Total (25 Marks)		100 %

Marks Obtained			Dated signature of Teacher
Process Related (15)	Product Related (10)	Total (25)	

Practical No. 8: Testing of given 70 W or higher rating LED for ingress of water to confirm the IP rating

I. Practical Significance:

This experiment helps students understand the importance of Ingress Protection (IP) testing in ensuring the durability and safety of LED luminaires used in outdoor or damp environments. It develops skills to perform water ingress tests and evaluate whether electrical equipment meets the required protection standards.

II. Industry/Employer Expected Outcome(s):

To develop the ability to perform IP testing procedures for electrical luminaires as per IS/IEC standards and evaluate compliance with protection ratings. Students are expected to demonstrate awareness of product quality, safety standards, and environmental protection requirements for lighting equipment used in industrial and outdoor applications.

III. Course Level Learning Outcome(s):

CO2 - Test electrical equipment.

IV. Laboratory Learning Outcome(s):

LLO 8.1 Test given LED for ingress of water to confirm the IP rating.

V. Relevant Affective Domain related outcome(s):

Develops a responsible attitude towards ensuring product safety, quality, and environmental compliance in electrical luminaires, demonstrating ethical practices and conscientiousness in industrial and outdoor lighting applications.

VI. Relevant Theoretical Background (With diagrams if required):

- Electric shock protection depends on preventing contact with live parts and controlling leakage/fault current.
- Basic insulation prevents shock in normal conditions.
- Supplementary, double, and reinforced insulation provide extra protection when basic insulation fails.
- Earthing (protective earth) is used to divert fault current and trip protective devices.
- Equipment insulation classes:
 - Class 0: Only basic insulation, no earthing.
 - Class I: Basic insulation + earthing for exposed metal parts.
 - Class II: Double/reinforced insulation, no earthing required.
- Insulation resistance must be high to ensure safety in all classes.

VII. Actual Circuit diagram used with equipment Specifications:

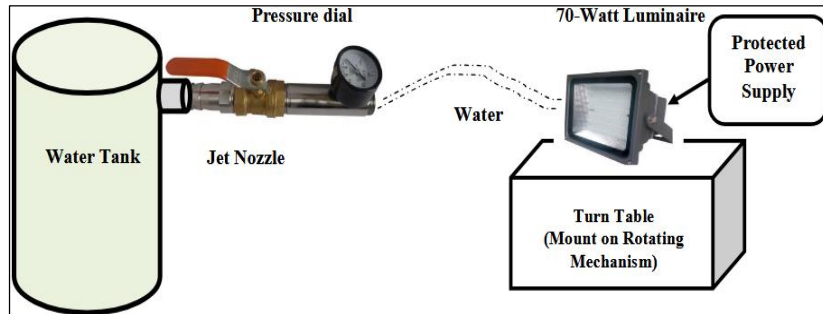

Fig 8.1 IP Water Ingress Test for 70 Watt Led (or +70 Watt)

VIII. Required Resources/apparatus/equipment with specification:

Sr. No.	Name of Resource	Suggested Broad Specification	Quantity
1.	LED luminaire	70 Watt or above	1 No.
2.	Water jet/spray arrangement	As per IP test requirement	1 No.
3.	Stopwatch or timer	As per standard	1 No
4.	Measuring scale or nozzle setup	As per standard	1 No
5.	Power supply	230V, 50Hz, AC	1 No.
6.	Dry cloth and inspection tools	Cotton	1 Set

IX. Precautions to be followed:

- Ensure electrical safety during testing—avoid water contact with live parts.
- Maintain correct pressure, nozzle size, and duration as per IP standard.
- Dry the luminaire before re-energizing.

X. Procedure:

- Note the IP rating mentioned on the LED luminaire.
- Ensure the LED is properly installed and its electrical connections are sealed.
- For testing water ingress (as per IEC 60529 / IS 12063):
 - Use the appropriate water jet or spray nozzle according to the IP code (e.g., 6.3 mm nozzle for IPX5 test).
 - Maintain the specified water pressure (30 ± 5 kPa) and distance (3 m).
- Expose the LED to water spray for the required duration (typically 3–5 minutes per surface).
- After testing, disconnect the power and dry the surface.

Maintenance of Electrical Equipments (316328)

- Open the enclosure and inspect for any water entry or moisture inside.
- Record the observations and determine if the luminaire meets the claimed IP rating.

XI. Observations and calculations:

Sr. no	IP Rating Claimed	Water Pressure (kPa)	Test Duration (Min)	Water Entry observed (Yes/No)	Result Pass/Fail
01					

XII. Results:

.....

.....

.....

.....

XIII. Interpretation of results:

.....

.....

.....

.....

XIV. Conclusion and recommendation:

.....

.....

.....

.....

XV. Practical related questions (Provide space for answers)

(Note: Below given are few sample questions for reference. Teachers must design more such questions so as to ensure the achievement of identified CO.)

1. What does the IP rating of an electrical equipment indicate?
2. Which standard or test method is used to determine the ingress protection level of LED luminaires?
3. During the IPX5 water test, what are the nozzle size, water pressure, and test duration specified for checking water ingress?

.....

.....

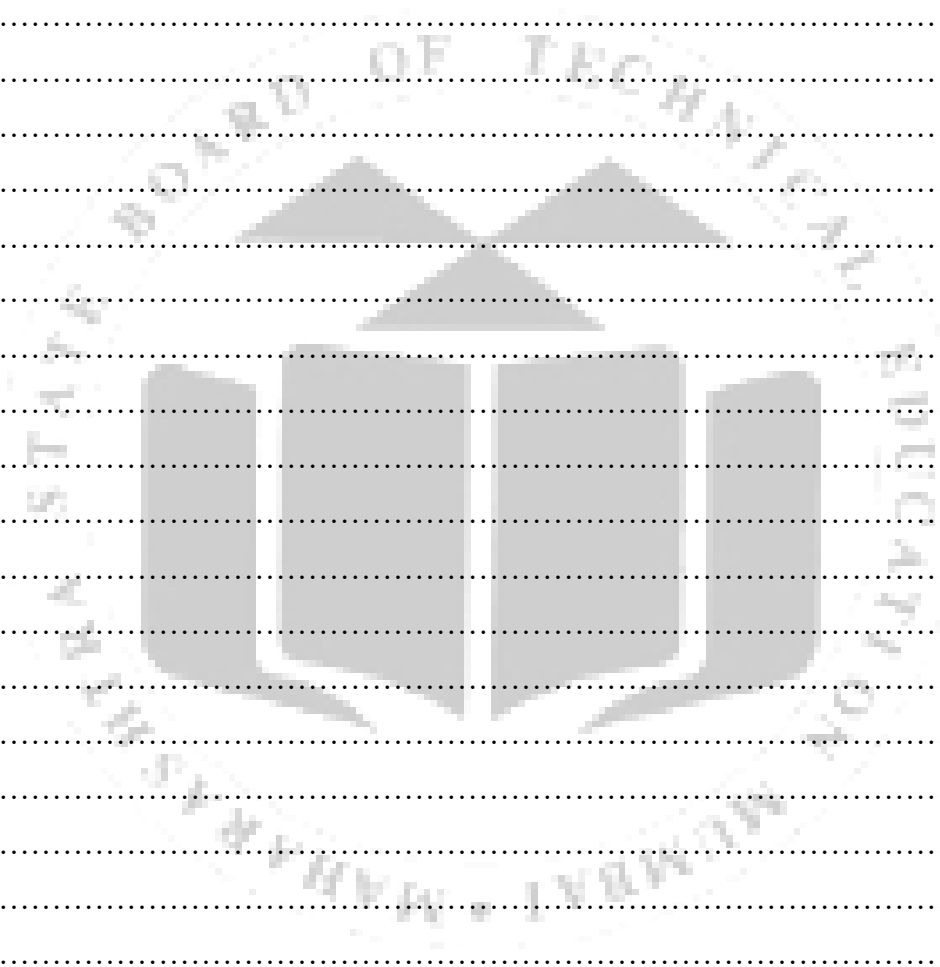

XVI. References/Suggestions for further reading:

1. <https://www.iec.ch/ip-ratings>
2. <https://www.iectestingequipment.com/sale-2210859-iec60529-ipx5-ipx6-ingress-protection-test-equipment-handheld-water-jet-nozzles-dia-6-3mm-12-5mm.html>
3. <https://Intsufin.com/product/aluminium-alloy-70-w-ip33-2700-6500-k-led-flood-lights/16087-10231>

Assessment Scheme:

Performance Indicators		Weightage
Process Related: (15 Marks)		60%
1	Handling of the components	10 %
2	Identification of component	20 %
3	Measuring value using suitable instrument	20 %
4	Working in team	10 %
Product Related: (10 Marks)		40%
5	Identify theoretical values of given component from datasheets	10 %
6	Interpretation of result	05 %
7	Conclusions	05 %
8	Practical related questions	15 %
9	Submitting the journal in time	05%
Total (25 Marks)		100 %

Marks Obtained			Dated signature of Teacher
Process Related (15)	Product Related (10)	Total (25)	

Practical No. 9: Maintenance of given induction motor.

I. Practical Significance:

This practical helps students develop hands-on skills to inspect, troubleshoot, and maintain induction motors, ensuring reliable operation, preventing faults, and extending equipment life. It also familiarizes them with standard maintenance procedures, safety practices, and proper handling of electrical machines

II. Industry/Employer Expected Outcome(s):

Ability to inspect, troubleshoot, and maintain induction motors safely and efficiently, preparing students for industrial electrical maintenance roles

III. Course Level Learning Outcome(s):

CO3 - Maintain rotating electrical machines.

IV. Laboratory Learning Outcome(s):

LLO 9.1 Carryout maintenance activities suggested in IS: 900-1992(Annex G) at 5,6,7 and 8 for maintenance of induction motors.

V. Relevant Affective Domain related outcome(s):

Develops a responsible and safety-conscious attitude toward maintaining electrical equipment, showing diligence, ethical work practices, and commitment to operational reliability.

VI. Relevant Theoretical Background (With diagrams if required):

Maintenance of electrical machines is vital for safety, efficiency, reliability, and cost-effectiveness. It helps ensure that machines operate optimally, reduces risk of accidents, and extends the useful life of equipment and machines.

Induction motors are widely used in industrial and commercial applications due to their robustness and simplicity. Understanding their construction including stator, rotor, bearings, and cooling systems is essential for maintenance. Knowledge of common faults such as insulation failure, bearing wear, rotor bar damage, and overheating is necessary to perform inspection, troubleshooting, and preventive maintenance effectively. Standard maintenance practices, safety procedures, and condition monitoring techniques ensure reliable operation and extend motor life. There are three main types of maintenance for electrical machines: routine, preventive, and breakdown maintenance.



Fig. 9.1- Phase Induction Motor

Each serves a specific purpose in keeping equipment safe and reliable:

Routine Maintenance

Routine maintenance involves scheduled, regular tasks such as cleaning, lubrication, tightening connections, and simple inspections to keep machines in good working condition. It helps prevent minor issues from affecting performance.

Preventive Maintenance

Preventive maintenance consists of planned actions performed at set intervals to catch and fix problems before breakdowns occur. This often includes more thorough inspections, part replacements, and testing to maintain reliability and extend equipment life.

Breakdown Maintenance

Breakdown (or corrective) maintenance is performed only after a machine fails or malfunctions. Repairs are done to restore function, but this method can cause unexpected downtime and higher costs compared to routine or preventive approaches.

VII. Actual Circuit diagram used with equipment Specifications:

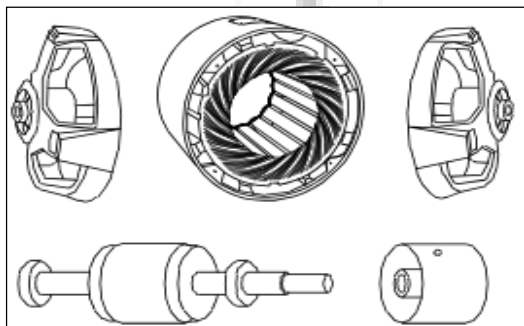

Fig. 9.2 Open View of 3-Ph IM

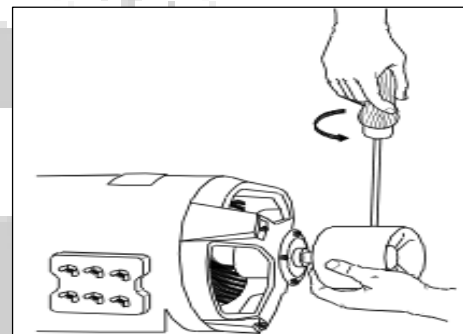

Fig. 9.3 Remove the shaft key

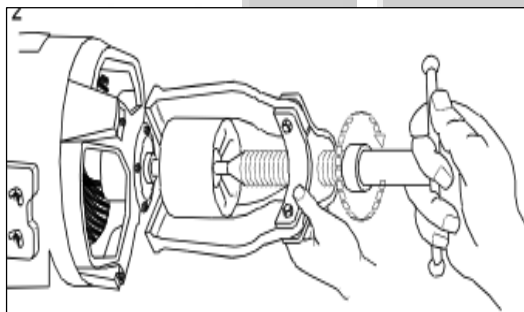

Fig. 9.4 Centre punch alignment

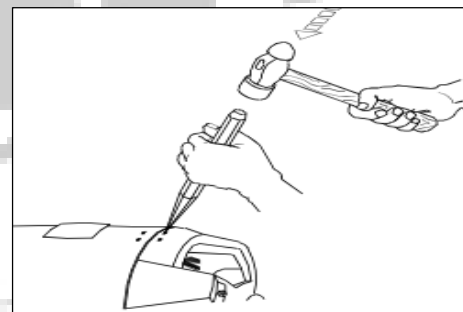

Fig. 9.5 Loosen the bolts

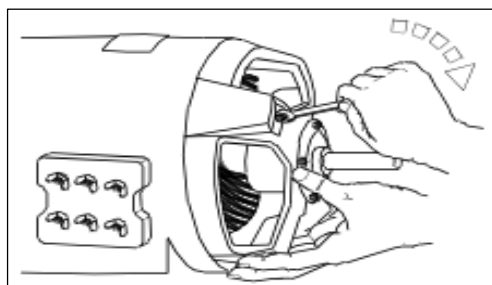

Fig. 9.6 Separate the stator and the end shield cove

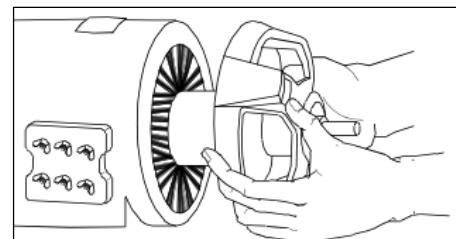

Fig. 9.7 Pull off the end shield cover & Rotor

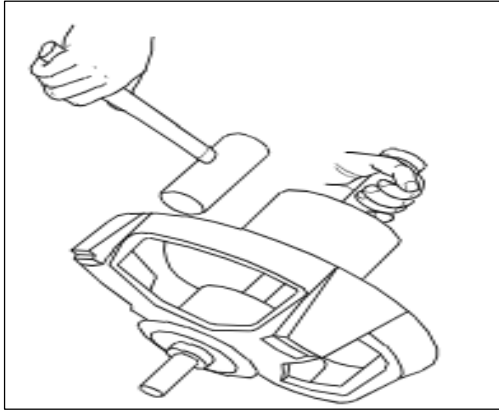

Fig. 9.8 Remove End Cover

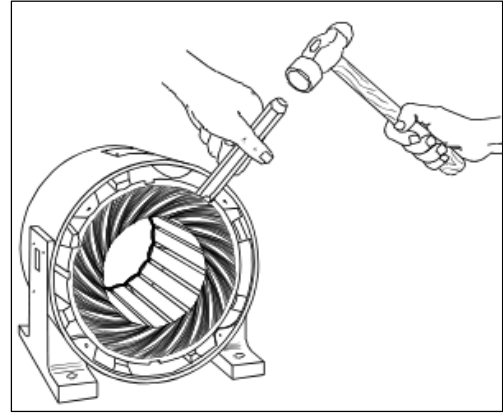

Fig.9.9 Cut out the burn coils

VIII. Required Resources/apparatus/equipment with specification:

Sr. No.	Name of Resource	Suggested Broad Specification	Quantity
1.	Three Phase Induction motor	3HP/5HP	1 No.
2.	Multimeter (Digital/Analog)	Range: 0–1000 V AC/DC, 0–10 A, resistance up to 20 MΩ	1 No.
3.	Insulated tool kit (screwdrivers, wrenches, pliers, and cutters etc.)	As per standard	1 Set
4.	Megger (Insulation Resistance Tester)	500 V / 1000 V DC	1 No
5.	Tachometer (Digital/Contact type)	Range: 0–5000 RPM	1 No
6.	Bearing Puller	Suitable for 0.5–5 HP motors	1 No
7.	Feeler Gauge	0.05–1 mm range	1 No
8.	Dial Gauge	Precision ±0.01 mm	1 No
9.	Grease Gun with Bearing Grease	Lithium-based, temperature grade NLGI-2	1 No
10.	Motor Starter (DOL/Star-Delta)	As per motor rating	1 No
11.	Insulated Gloves & Safety Shoes	As per IS:4770	1 No
12.	Hammer	As per Standard	1 No

IX. Precautions to be followed:

1. Always isolate the motor from its power source before any work.
2. Discharge any capacitors associated with the motor.
3. Wear insulated gloves, safety glasses, face shields, and flame-resistant clothing to protect from electrical shock, sparks, and burns.
4. Ensure that only trained and authorized individuals perform maintenance.
5. Use insulated and appropriately rated tools for electrical work.
6. Verify that the motor and all metal parts are properly grounded to prevent electrical shock hazards
7. Keep the area clean and free of clutter to avoid slips, trips, and mistakes.
8. Avoid wearing items that can get caught in rotating or moving parts of the motor.
9. Adhere strictly to the manufacturer's maintenance procedures and local safety regulations.

X. Procedure:

Routine Maintenance

- Isolate the motor from power, apply lockout/tagout.
- Visually inspect exterior for dust, corrosion, loose mounts, or leaks.
- Clean the motor housing and cooling vents using a soft cloth or vacuum.
- Check for abnormal vibration, sound, or smell while running (if safe to do so).
- Record operating voltage and current; compare with rated values.
- Check earth connection and mounting bolts for tightness.

Preventive Maintenance

- Repeat all steps of routine maintenance.
- Lubricate bearings as per schedule (use manufacturer-recommended grease).
- Inspect and tighten all terminal and connection points.
- Measure and record insulation resistance of windings with a megger.
- Test motor protections and starter function; clean starter contacts.
- Check alignment of motor shaft and coupling.
- Replace air filters or clean if applicable.

Breakdown Maintenance

- Isolate and tag the motor from electrical supply.
- Diagnose the fault using appropriate test equipment (multimeter, insulation tester, vibration analyzer).
- Inspect all accessible areas for burnt windings, broken parts, or damaged bearings.
- Remove and replace or repair any faulty components (bearings, windings, connections).
- Clean internal and external parts before re-assembly.
- Test motor after repairs for proper operation (voltage, current, temperature, vibration).
- Record all repair actions for documentation and future reference.

XI. Observations and calculations:

Type of Maintenance	Frequency / Schedule	Maintenance Activities / Tasks	Purpose / Remarks
Routine Maintenance			
Preventive Maintenance			
Break down Maintenance			

XII. Results:

.....
.....
.....
.....

XIII. Interpretation of results:

.....
.....
.....

XIV. Conclusion and recommendation:

.....
.....
.....

XV. Practical related questions (Provide space for answers)

(Note: Below given are few sample questions for reference. Teachers must design more such questions so as to ensure the achievement of identified CO.)

1. What are the differences between routine, preventive, and breakdown maintenance in a three-phase induction motor?
2. Why is insulation resistance testing important during preventive maintenance?
3. List any three tools or instruments used during the maintenance of a three-phase induction motor and state their purposes.

.....
.....
.....
.....
.....
.....
.....
.....
.....
.....
.....

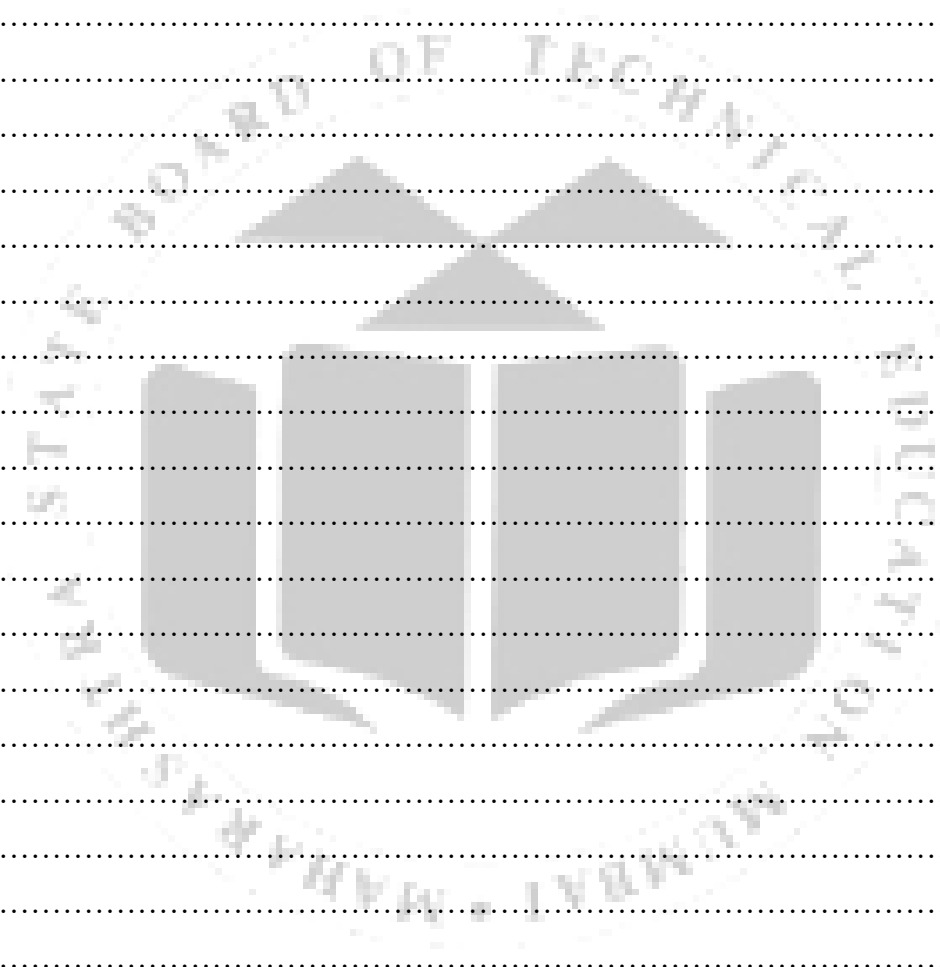

XVI. References/Suggestions for further reading:

1. <https://circuitcellar.com/resources/quickbits/induction-motors/>
2. <https://www.servicetitan.com/blog/electrical-maintenance-program>
3. <https://www.interplaylearning.com/blog/different-types-of-maintenance/>

Assessment Scheme:

Performance Indicators		Weightage
Process Related: (15 Marks)		60%
1	Handling of the components	10 %
2	Identification of component	20 %
3	Measuring value using suitable instrument	20 %
4	Working in team	10 %
Product Related: (10 Marks)		40%
5	Identify theoretical values of given component from datasheets	10 %
6	Interpretation of result	05 %
7	Conclusions	05 %
8	Practical related questions	15 %
9	Submitting the journal in time	05%
Total (25 Marks)		100 %

Marks Obtained			Dated signature of Teacher
Process Related (15)	Product Related (10)	Total (25)	

Practical No. 10: Maintenance of given transformer.

I. Practical Significance:

This practical helps students develop hands-on skills to inspect, troubleshoot, and maintain transformers, ensuring reliable operation, preventing faults, and extending equipment life. It also familiarizes them with standard maintenance procedures, safety practices, and proper handling of electrical apparatus

II. Industry/Employer Expected Outcome(s):

To develop the ability to perform inspection, testing, and preventive maintenance of transformers, ensuring reliability, safety, and efficient operation.

III. Course Level Learning Outcome(s):

CO4 - Maintain single phase and three phase transformers.

IV. Laboratory Learning Outcome(s):

LLO 10.1 Carryout maintenance activities suggested in IS: 10028- part 3 at 1,2,3 and 4 for maintenance of transformer.

V. Relevant Affective Domain related outcome(s):

Develops a sense of responsibility, safety awareness, and commitment to follow standard maintenance procedures and work ethics while performing transformer maintenance tasks.

VI. Relevant Theoretical Background (With diagrams if required):

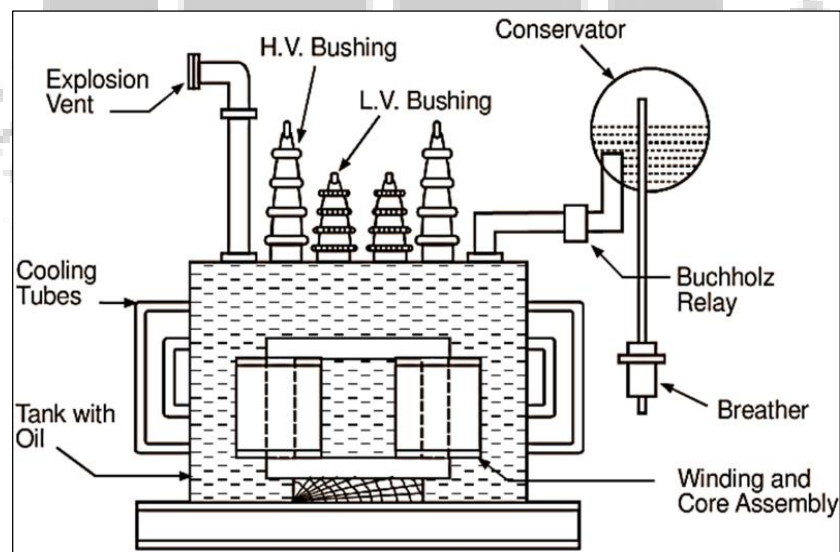

Fig.10.1 Schematic Representation of large capacity single phase transformer

Theoretical Background (as per IS: 10028 – Part 3)

1. Principle of Transformer Operation:

- Works on the principle of electromagnetic induction transfer of electrical energy between primary and secondary windings through a magnetic core.

2. Types and Construction:

- Knowledge of single-phase and three-phase transformers.
- Main parts: core, windings, tank, bushings, conservator, breather, tap changer, and cooling system.

3. Transformer Ratings and Parameters:

- Understanding voltage, current, kVA rating, impedance, vector group, and efficiency.

4. Transformer Oil and Insulation:

- Role of transformer oil in cooling and insulation.
- Concept of dielectric strength and oil testing as per IS: 335.

5. Maintenance Concepts (as per IS:10028 Part 3):

- Routine inspection: Visual checks for leakage, cleanliness, and connections.
- Electrical tests: Insulation resistance, winding resistance, and oil BDV test.
- Mechanical checks: Tightening of connections, condition of bushings, cooling system.
- Operational checks: Monitoring temperature, load current, and noise levels.

6. Safety and Precautions:

- Isolation of supply before maintenance.
- Use of proper PPE, earthing, and adherence to safety norms.

VII. Actual Circuit diagram used with equipment Specifications:

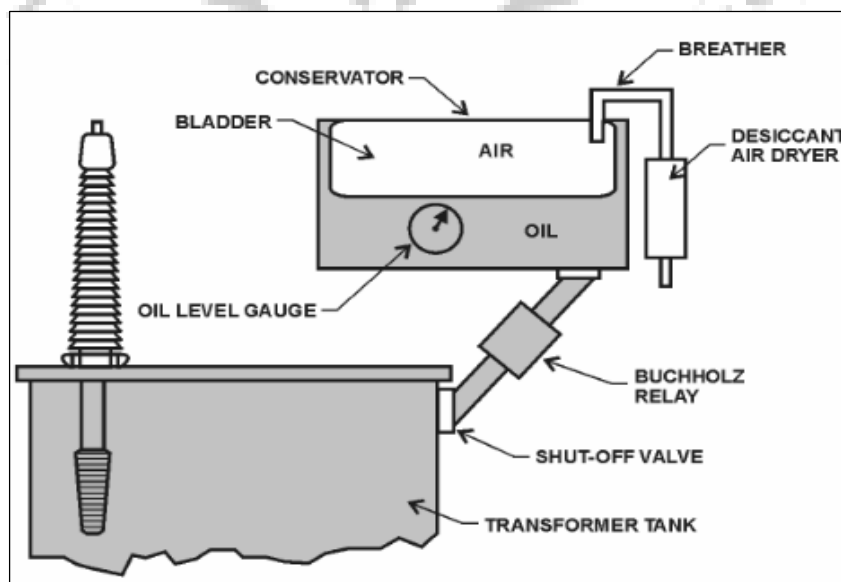

Fig. 10.2 Parts of Transformer

VIII. Required Resources/apparatus/equipment with specification:

Sr. No.	Name of Resource	Suggested Broad Specification	Quantity
1.	Single-phase Transformer (large capacity) or as per available.	1KVA to 25 kVA, 230/440 V, 50 Hz	1 No.
2.	Insulation Resistance (IR) Tester / Megger	Hand or digital type, 500 V / 1000 V	1 No
3.	Multimeter	Digital, 0–600 V AC/DC, 0–10 A, resistance up to 20 MΩ	1 No
4.	Oil Testing Kit (BDV Tester)	0–100 kV, automatic / manual type	1 No
5.	Thermometer / Temperature Gun	Range: 0–150°C	1 No
6.	Spanners and Screwdrivers Set	Insulated, assorted sizes	1 No
7.	PPE (Personal Protective Equipment)	Safety gloves, shoes, helmet, goggles	1 Set of Each

IX. Precautions to be followed:

1. Ensure the transformer is completely isolated from the power supply before starting any maintenance.
2. Discharge stored charges from windings and bushings before touching terminals.
3. Use only insulated tools and instruments while working on electrical parts.
4. Wear proper PPE (Personal Protective Equipment) such as gloves, safety shoes, and goggles.
5. Check the earthing system of the transformer before performing any testing or measurement.
6. Do not open the transformer tank or remove oil while it is energized or hot.
7. Handle transformer oil carefully; avoid contact with skin and eyes and dispose of used oil properly.
8. Keep water and moisture away from electrical parts and open terminals.
9. Maintain a safe distance from live parts when energizing for testing.
10. Follow correct polarity and connection procedures during reassembly and testing.
11. Do not exceed rated voltage, current, or load during testing.

X. Procedure:

Daily Maintenance Steps

- Visually inspect the transformer for oil leaks, damaged bushings, and loose connections.
- Check and record the oil level in the main and conservator tanks; top up if needed.
- Examine the silica gel breather; replace the gel if it has changed from blue to pink.
- Check the temperature indicators (oil and winding) and record readings.
- Monitor noise and vibration levels; unusual levels can indicate internal faults.
- Check the color of silica gel and replace it if saturated.
- Ensure all indicator lights, protection devices, and alarms are functional.
- Document any abnormalities observed.

Monthly Maintenance Steps

- Repeat daily checks; pay extra attention to persistently abnormal readings or observations.
- Inspect and clean silica gel breathers to ensure proper functioning.
- Check all cooling systems fans, radiators, oil pumps for proper function.
- Verify the oil level in bushings if applicable.

Maintenance of Electrical Equipments (316328)

- Conduct functional tests on protective relays and alarm circuits. Perform a general cleaning of the transformer and its surroundings to prevent dust or debris accumulation.

Annual Maintenance Steps

- Clean all bushings with a soft, lint-free cloth.
- Take oil samples from the drain valve to test dielectric strength (BDV) and moisture; replace oil if BDV is low or moisture (PPM) is high.
- Check, clean, and test the marshalling box (control and relay panel).
- Test and tighten all terminal connections.
- Clean and test all switches, alarms, relays, and circuits.
- Test the resistivity of the earth connection.
- Physically inspect and service Buchholz and pressure release device relays.
- Check, clean, and test tap changers; ensure smooth operation.
- Perform insulation resistance tests for windings and bushings.
- Conduct a comprehensive visual and operational inspection of core and coil assembly, tank, and enclosure for corrosion, damage, or deformation.
- Document all maintenance activities for compliance and trend analysis.

XI. Observations and calculations:

Sr. no	Type of Maintenance	Frequency of Maintenance	Maintenance activities	Remarks
01	Routine Maintenance			
02	Monthly Maintenance			
03	Quarterly Maintenance			
04	Half-Yearly Maintenance			
05	Yearly Maintenance			

XII. Results:

.....
.....
.....
.....

XIII. Interpretation of results:

.....
.....
.....

XIV. Conclusion and recommendation:

.....
.....
.....

XV. Practical related questions (Provide space for answers)

(Note: Below given are few sample questions for reference. Teachers must design more such questions so as to ensure the achievement of identified CO.)

1. What are the differences between routine, preventive, and breakdown maintenance in a three-phase induction motor?
2. What are the main maintenance activities performed to ensure the reliable operation of a transformer?

.....
.....
.....
.....
.....
.....
.....
.....
.....
.....
.....
.....
.....
.....
.....
.....

XVI. References/Suggestions for further reading:

1. <https://kishorekaruppaswamy.wordpress.com/wp-content/uploads/2015/06/studytransformers.pdf>
2. <https://deltawye.com/transformer-maintenance-checklist/>

Assessment Scheme:

Performance Indicators		Weightage
Process Related: (15 Marks)		60%
1	Handling of the components	10 %
2	Identification of component	20 %
3	Measuring value using suitable instrument	20 %
4	Working in team	10 %
Product Related: (10 Marks)		40%
5	Identify theoretical values of given component from datasheets	10 %
6	Interpretation of result	05 %
7	Conclusions	05 %
8	Practical related questions	15 %
9	Submitting the journal in time	05%
Total (25 Marks)		100 %

Marks Obtained			Dated signature of Teacher
Process Related (15)	Product Related (10)	Total (25)	

Practical No. 11: Diagnosis and rectification of faults for a ceiling fan running Slow.

I. Practical Significance:

These practical enables students to identify and rectify causes of a ceiling fan running slow by checking capacitor, bearings, windings, and supply conditions, enhancing their fault diagnosis and maintenance skills.

II. Industry/Employer Expected Outcome(s)

Ability to safely and efficiently diagnose and repair slow-running ceiling fans as per standards. The goal is to identify faults such as a defective capacitor, mechanical friction, or wiring issue, and restore normal operation. This ensures reliability, safety, and customer satisfaction through proper maintenance practices.

III. Course Level Learning Outcome(s)

CO3 - Maintain rotating electrical machines.

IV. Laboratory Learning Outcome(s)

LLO 11.1 Identify the parts of single-phase induction motor.

LLO 11.2 Rectify the basic faults in given single phase induction motor

V. Relevant Affective Domain related outcome(s)

Develops a responsible and safety-conscious attitude while performing diagnostic and repair tasks, demonstrates patience and accuracy in fault identification, and shows commitment to maintaining quality, reliability, and customer satisfaction during maintenance work.

VI. Relevant Theoretical Background (With diagrams if required)

A ceiling fan operates on a single-phase induction motor principle. Reduced speed can result from a faulty capacitor (causing reduced phase shift), worn-out bearings (increasing friction), low supply voltage, or damaged windings. Proper diagnosis involves checking mechanical and electrical parameters, ensuring correct capacitor value, and maintaining lubrication for smooth rotation.

Parts of Ceiling fan

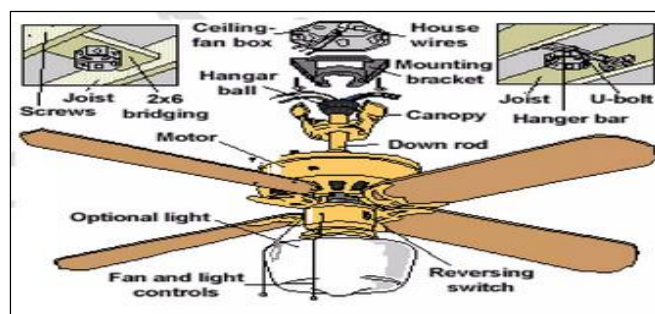

Fig. 11.1 Parts of ceiling fan

VII. Actual Circuit diagram used in laboratory with equipment Specifications:

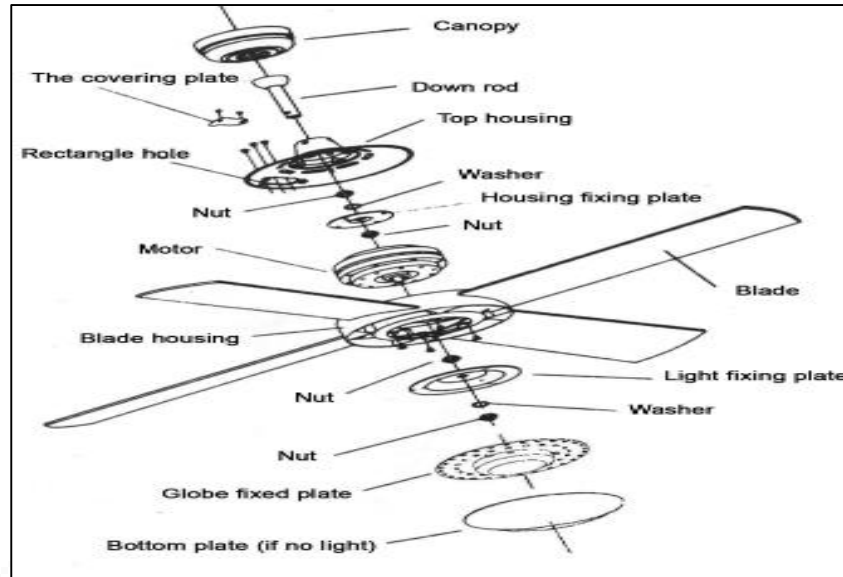

Fig.11.2 Assembly of ceiling fan

VIII. Required Resources / apparatus / equipment with specification:

Sr. No.	Name of Resource	Suggested Broad Specification	Quantity
1.	Ceiling Fan	230 V, 50 Hz, 60–75 W	1 No
2.	Multimeter	Digital type, 0–600 V, 0–10 A	1 No
3.	Tachometer	Contact / non-contact type	1 No
4.	Capacitor	2.25 μ F to 4 μ F, 440 V AC	1 No
5.	Screwdriver Set	Insulated type	1 Set
6.	Spanners and Pliers	Insulated handle type	1 Set

IX. Precautions to be followed:

- Always disconnect power supply before working on the fan.
- Use insulated tools and wear PPE.
- Handle the capacitor carefully; ensure it is discharged before testing.
- Avoid touching live wires or terminals.
- Ensure proper alignment and tightening of blades after reassembly.

X. Procedure:

- Isolate the fan from the power supply.
- Inspect the blades for dust accumulation or imbalance.

Maintenance of Electrical Equipments (316328)

- Check bearing condition and apply lubrication if needed.
- Test the supply voltage and current drawn using a multimeter.
- Measure fan speed using a tachometer and compare with rated speed.
- Check the capacitor value; replace if found below rated capacity.
- Inspect windings for continuity and insulation resistance.
- Reassemble, test the fan again, and verify normal speed operation.

XI. Observations and calculations:

Sr. no	Parameter	Measured Value	Remark
01	Supply Voltage (V)		
02	Current (A)		
03	Speed (RPM)		
04	Capacitor (μ F)		

XII. Results:

.....

.....

.....

.....

XIII. Interpretation of results:

.....

.....

.....

.....

XIV. Conclusion and recommendation

.....

.....

.....

.....

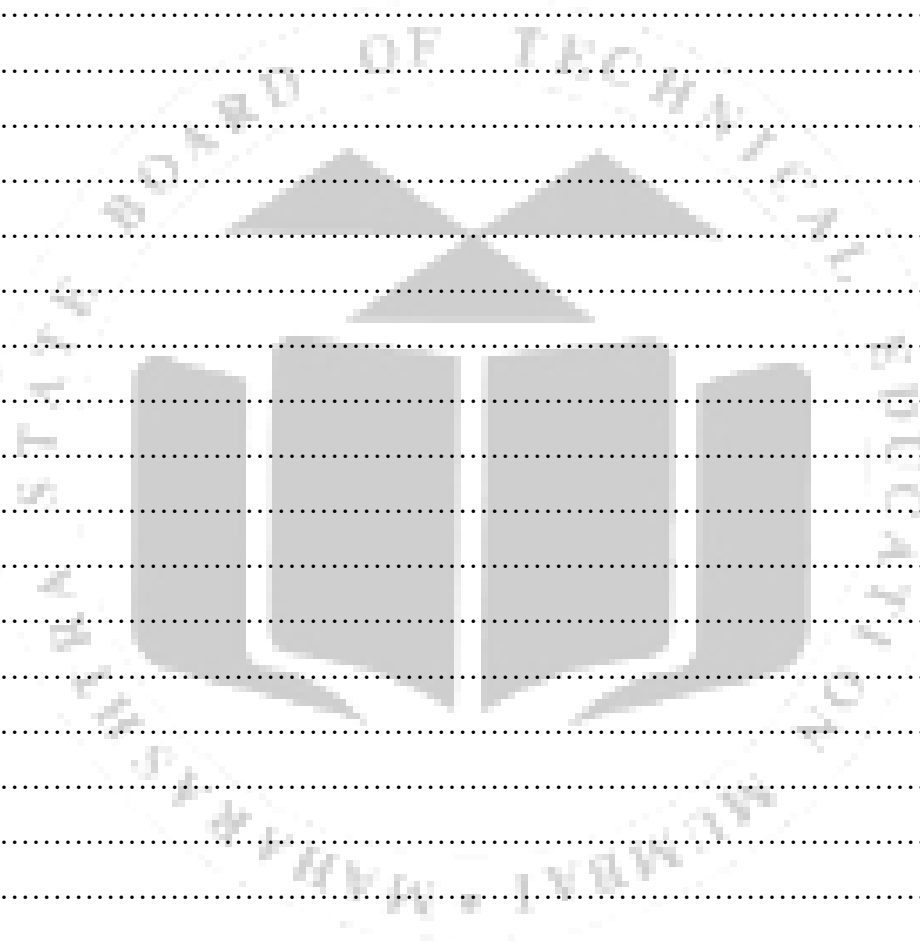

XVI. References/Suggestions for further reading:

1. <https://dokumen.live/reviews/s38C72/244331/4980871-ceiling-fan-working-procedure-with-diagram>
2. <https://www.fanco.com.au/wp-content/uploads/2020/04/Urban-2-dc-manual.pdf>

Assessment Scheme:

Performance Indicators		Weightage
Process Related: (15 Marks)		60%
1	Handling of the components	10 %
2	Identification of component	20 %
3	Measuring value using suitable instrument	20 %
4	Working in team	10 %
Product Related: (10 Marks)		40%
5	Identify theoretical values of given component from datasheets	10 %
6	Interpretation of result	05 %
7	Conclusions	05 %
8	Practical related questions	15 %
9	Submitting the journal in time	05%
Total (25 Marks)		100 %

Marks Obtained			Dated signature of Teacher
Process Related (15)	Product Related (10)	Total (25)	

Practical No. 12: Diagnosis and rectification of faults for a ceiling fan running in reverse direction.

I. Practical Significance:

These practical helps students identify and rectify faults causing a ceiling fan to run in the reverse direction, enhancing their skills in motor wiring diagnosis, troubleshooting, and safe repair practices.

II. Industry/Employer Expected Outcome(s)

Ability to diagnose wiring or connection faults causing a ceiling fan to run in the reverse direction and apply appropriate rectification methods to ensure correct rotation, safety, and reliable operation as per industry maintenance standards.

III. Course Level Learning Outcome(s)

CO3 - Maintain rotating electrical machines.

IV. Laboratory Learning Outcome(s)

LLO 12.1 Identify the parts of single-phase induction motor.

LLO 12.2 Rectify the basic faults in given single phase induction motor.

V. Relevant Affective Domain related outcome(s)

Develops a responsible and safety-conscious attitude while diagnosing and rectifying faults, showing patience, accuracy, and commitment to restoring proper fan operation as per standard maintenance practices.

VI. Relevant Theoretical Background (With diagrams if required)

Understanding the working principle of single-phase induction motors, the function of main and auxiliary windings, and the role of the capacitor in determining the direction of rotation is essential. Knowledge of fan wiring diagrams, phase relationship between windings, and common wiring faults helps in identifying and correcting reverse rotation issues effectively.

In a single-phase AC ceiling fan motor, the direction of rotation is determined by the phase relationship between the

main (run) winding and the **auxiliary (start) winding** (which is in series with a capacitor). The direction is reversed by changing the polarity of the voltage to one of the windings, which effectively changes which winding gets the phase-shifted current

Normal Rotation (Counter clockwise)

- Configuration: The fan is typically designed to run counter clockwise in its default or "normal" configuration for summer cooling.
- Wiring: The main supply (Live and Neutral) is connected to the winding combination in a specific way. The capacitor is in series with the auxiliary (start) winding, creating a phase shift (typically 90 degrees) in its current compared to the main winding's current. This phase difference generates

a rotating magnetic field in one direction, causing the rotor to spin counter clockwise (when viewed from below).

Reverse Rotation (Clockwise)

- **Configuration:** For reverse (clockwise) rotation, used in winter to pull cool air up and push warm air down the walls, the wiring connection to one of the windings (usually the auxiliary winding) is inverted.
- **Wiring Change:** To manually reverse the direction, you need to reverse the connections of either the main winding *or* the auxiliary winding terminals relative to the other.
 - A common method is to swap the connections to the two ends of the auxiliary winding (the one with the capacitor in series) where they connect to the main power supply and the run winding.
 - This changes the direction of the rotating magnetic field, making it spin clockwise, which in turn reverses the fan's physical rotation.

VII. Actual Circuit diagram used in laboratory with equipment Specifications:

1. Normal direction

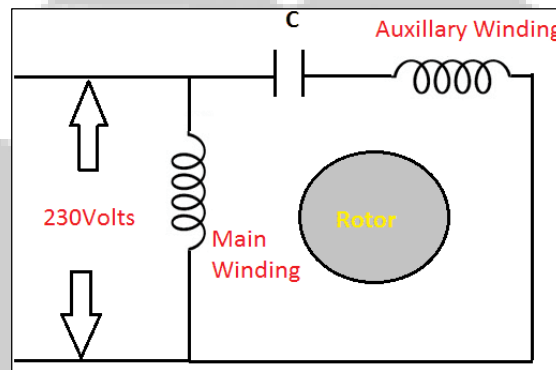

Fig. 12.1 Single Phase Induction motor

2. Draw the circuit diagram for reversal of direction by interchanging the main winding connections

3. Draw the circuit diagram for reversal of direction by interchanging the Auxiliary winding connections

VIII. Required Resources / apparatus / equipment with specification:

Sr. No.	Name of Resource	Suggested Broad Specification	Quantity
01	Single phase Induction motor	Single phase 1HP 230 V 50Hz Capacitor start IM	01 No
02	Screw driver	Suitable set	01 No
03	Multimeter	Digital	01 No
04	Tester	Stainless Steel	01 No

IX. Precautions to be followed:

- Ensure the fan is completely disconnected from the power supply before inspection or repair.
- Use insulated tools and wear safety gear such as gloves and shoes.
- Verify capacitor discharge before handling to avoid electric shock.
- Follow correct wiring connections as per the circuit diagram.
- Avoid touching rotating parts or live terminals during testing.
- Check all connections securely before energizing the fan.
- Ensure the fan blades are properly fixed and balanced after rectification.
- Conduct the test under supervision and adhere to standard safety practices.

X. Procedure:

1. Preparation

- Disconnect the fan from the power supply.
- Keep the required tools and instruments ready (multimeter, screwdrivers, tester, insulation tape, etc.).
- Ensure the fan is mounted securely or placed safely on a working bench.

- Note the fan's wiring connections before starting work.

2. Visual Inspection

- Inspect the fan for any loose, burnt, or damaged wires.
- Check the capacitor's physical condition (bulging, leakage, or loose connection).
- Verify that the switch and regulator connections are intact.

3. Checking Main Winding Connections

- Using a multimeter, measure the continuity and resistance of the main winding.
- Typical resistance of the main winding is lower than that of the auxiliary winding.
- If the winding is open or shorted, repair or replace it as required.
- Ensure correct connection of the main winding between the supply line and neutral.

4. Checking Auxiliary Winding Connections

- Measure the resistance of the auxiliary (starting) winding — it should show continuity and slightly higher resistance than the main winding.
- Confirm that one end of the auxiliary winding is connected through the capacitor to the supply line.
- If the auxiliary winding connections are interchanged, it will cause reverse rotation.
- Correct the wiring as per the fan's circuit diagram (connect the proper ends of both windings).

5. Checking Capacitor and Its Connections

- Disconnect the capacitor and test it with a capacitance meter or multimeter (capacitance mode).
- Verify that the capacitance value matches the rated value (usually 2.5–4 μF for ceiling fans).
- Check capacitor terminals and wires for continuity and tightness.
- Replace the capacitor if defective or of incorrect value.
- Reconnect the capacitor properly in series with the auxiliary winding.

6. Reconnection and Testing

- Reconnect all wires as per the standard connection diagram:
 - Main winding directly across supply.
 - Auxiliary winding connected through the capacitor.
- Tighten all connections securely.
- Switch ON the supply and observe the direction of rotation.

7. Verification

- Ensure the fan rotates in the correct (normal) direction and provides proper airflow.
- Check for smooth and vibration-free operation.
- If the fan still runs in reverse, recheck the auxiliary and capacitor connections.

8. Completion

- Switch OFF the supply and reassemble the fan properly.
- Record the observations and rectifications performed.
- Clean the workspace and store tools properly.

XI. Observations and calculations:

Sr. No.	Condition	Direction of rotation of fan	Remark
01	Initial connection		
02	Interchanging Main winding connections		
03	Interchanging Auxiliary winding connections		

XII. Results:

.....

.....

.....

.....

XIII. Interpretation of results:

.....

.....

.....

.....

XIV. Conclusion and recommendation

.....

.....

.....

XV. Practical related questions (Provide space for answers)

(Note: Below given are few sample questions for reference. Teachers must design more such questions so as to ensure the achievement of identified CO.)

1. What causes a ceiling fan to run in the reverse direction, and how can it be corrected?
2. How does reversing the auxiliary winding connections affect the direction of rotation of a ceiling fan?
3. What is the function of the capacitor in determining the direction of rotation of a ceiling fan?

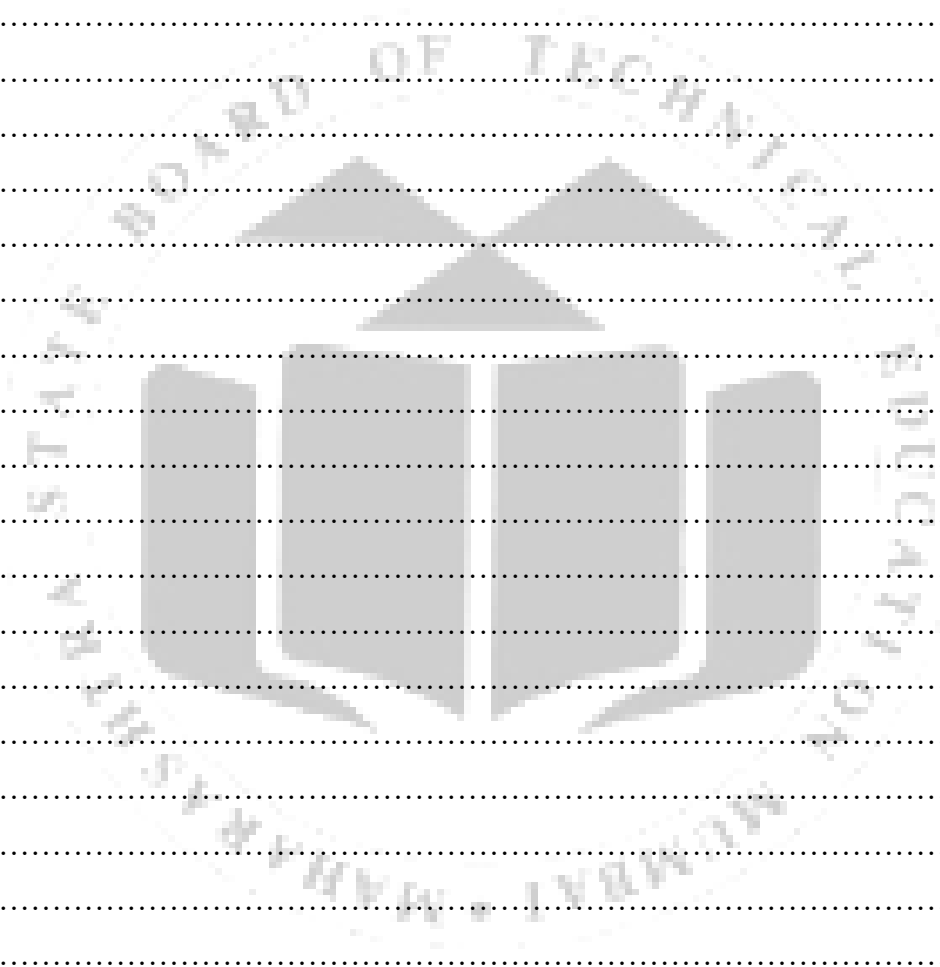

XVI. References/Suggestions for further reading:

1. <https://www.electrical4u.net/electrical/forward-reverse-direction-of-induction-motor-and-dc-motor/>

Assessment Scheme:

Performance Indicators		Weightage
Process Related: (15 Marks)		60%
1	Handling of the components	10 %
2	Identification of component	20 %
3	Measuring value using suitable instrument	20 %
4	Working in team	10 %
Product Related: (10 Marks)		40%
5	Identify theoretical values of given component from datasheets	10 %
6	Interpretation of result	05 %
7	Conclusions	05 %
8	Practical related questions	15 %
9	Submitting the journal in time	05%
Total (25 Marks)		100 %

Marks Obtained			Dated signature of Teacher
Process Related (15)	Product Related (10)	Total (25)	

Practical No. 13: Measurement of winding resistance of a single-phase induction motor by V-I method. (before and after no load running).

I. Practical Significance:

To understand the method of determining the phase winding resistance of a single-phase induction motor using the V–I method. To study the effect of temperature on winding resistance before and after no-load running of the motor.

II. Industry/Employer Expected Outcome(s)

Students will be able to measure the DC resistance of motor windings accurately using suitable instruments. They will understand how temperature variations affect the electrical characteristics and performance of induction motors during operation.

III. Course Level Learning Outcome(s)

CO3 - Maintain rotating electrical machines.

IV. Laboratory Learning Outcome(s)

LLO 13.1 Test the insulation condition of single-phase induction motor (before and after no load running)

V. Relevant Affective Domain related outcome(s)

Develops careful and safe working habits while performing electrical measurements on machines. Demonstrates responsibility in handling instruments and observing safety precautions during testing. Shows curiosity and initiative in analyzing the effect of temperature on motor winding resistance.

VI. Relevant Theoretical Background (With diagrams if required)

Before performing this practical, students should have a clear understanding of the construction and working principle of a single-phase induction motor, which consists of a stator with two windings the main (running) winding and the auxiliary (starting) winding and a rotor of the squirrel cage type. The main and auxiliary windings are responsible for producing the starting torque and maintaining motor operation.

Students should be familiar with Ohm's Law ($V = IR$), which relates voltage, current, and resistance, as it forms the basis of the V–I method used to determine winding resistance. In this method, a DC voltage is applied across the winding, the current flowing through it is measured, and the resistance is calculated by dividing the measured voltage by the current.

They should also understand that when a motor operates under no-load condition, the temperature of the windings increases due to internal losses (I^2R losses). As the temperature of the conductor rises, its resistance also increases. Therefore, by measuring the winding resistance before and after no-load running, the relationship between temperature and resistance can be studied.

Additionally, students must know basic electrical safety principles such as keeping current within safe limits, ensuring correct wiring, and preventing electric shocks while handling both DC and

AC circuits. This theoretical understanding helps in performing the experiment safely and obtaining accurate results.

VII. Actual Circuit diagram used in laboratory with equipment Specifications:

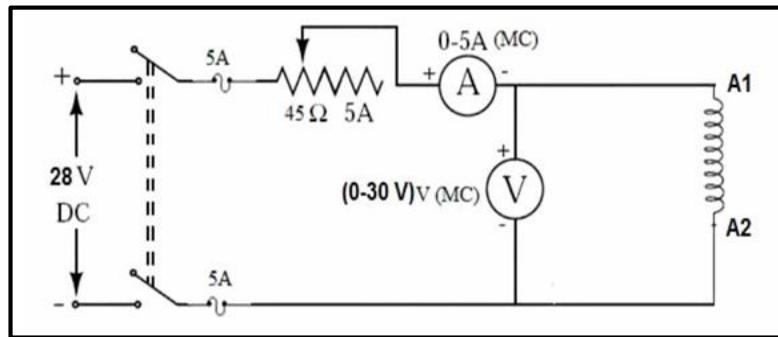

Fig.13.1 Measurement of resistance by using V-I Method

VIII. Required Resources / apparatus / equipment with specification:

Sr. No.	Name of Resource	Suggested Broad Specification	Quantity
01	Single phase Induction motor	Single phase 1HP 230 V 50Hz Capacitor start IM	01 No
02	DC power supply / Battery / Rectifier	0-50 V DC, 2 A	01 No
03	Voltmeter (DC)	0-50 V	01 No
04	Ammeter (DC)	0-5 A	01 No
05	Connecting leads	As Per Required	-

IX. Precautions to be followed:

- Use DC supply only for resistance measurement.
- Keep the current low to avoid overheating.
- Ensure all connections are correct and tight.
- Switch off the supply immediately after noting readings.
- Allow the motor to stop completely before reconnecting for DC test.

X. Procedure:

1. Measurement Before No-Load Running

- Connect the circuit as per the diagram.
- Keep the DC supply at zero voltage initially.
- Switch ON the supply and gradually increase the voltage until a small current (below 10 % of rated) flows through the winding.
- Note the voltmeter (V) and ammeter (I) readings.
- Calculate the resistance using Ohm’s Law: $R=V/I$.
- Repeat the above steps for both main and auxiliary windings.
- Record all readings in the observation table (Before Running).

2. Measurement After No-Load Running

- Disconnect the AC supply and allow the rotor to stop completely.
- Reconnect the DC circuit for resistance measurement.
- Repeat the same steps (as in Part 1) for both windings.
- Record all readings in the observation table (After Running).

XI. Observations and calculations:

Sr. no	Load Condition	Winding Type	Voltage (V)	Current (I)	Resistance (Ω)
01	Before No-Load	Main Winding			
02		Auxiliary Winding			
03	After No-Load	Main Winding			
04		Auxiliary Winding			

XII. Results:

- Resistance of main winding before no-load = _____ Ω
- Resistance of main winding after no-load = _____ Ω
- Resistance of auxiliary winding before no-load = _____ Ω
- Resistance of auxiliary winding after no-load = _____ Ω

XIII. Interpretation of results:

.....

.....

.....

.....

XIV. Conclusion and recommendation

.....

.....

.....

.....

XVI. References/Suggestions for further reading:

1. B.L. Theraja & A.K. Theraja, *A Textbook of Electrical Technology – Vol. II: AC & DC Machines*, S. Chand Publications, New Delhi

Assessment Scheme:

Performance Indicators		Weightage
Process Related: (15 Marks)		60%
1	Handling of the components	10 %
2	Identification of component	20 %
3	Measuring value using suitable instrument	20 %
4	Working in team	10 %
Product Related: (10 Marks)		40%
5	Identify theoretical values of given component from datasheets	10 %
6	Interpretation of result	05 %
7	Conclusions	05 %
8	Practical related questions	15 %
9	Submitting the journal in time	05%
Total (25 Marks)		100 %

Marks Obtained			Dated signature of Teacher
Process Related (15)	Product Related (10)	Total (25)	

Practical No.14: Reduced voltage running up test of three phase induction motor.

I Practical Significance:

To study the starting characteristics of a three-phase induction motor under reduced voltage conditions. To understand the effect of applied voltage on starting current, torque, and speed during the motor's run-up period.

II Industry/Employer Expected Outcome(s):

Students are Able to analyze motor starting performance and select appropriate starting methods (such as star-delta or autotransformer starting) based on load conditions. Capability to minimize high inrush current and mechanical stress on motor and connected equipment during starting in industrial applications.

III Course Level Learning Outcome(s):

CO3 - Maintain rotating electrical machines.

IV Laboratory Learning Outcome(s):

LLO 14.1 Test the three phase induction motor before commissioning.

V Relevant Affective Domain Related Outcome(s):

Develops a positive attitude toward careful observation and accurate measurement during motor testing. Demonstrates responsibility and safety awareness while handling three-phase electrical equipment.

VI Relevant Theoretical Background:

The three-phase induction motor is one of the most commonly used electrical machines in industries because of its rugged construction, simple design, and reliable operation. However, one of its major drawbacks is the high starting current drawn when the motor is started directly on full supply voltage. When the motor is at standstill, there is no back electromotive force (EMF) induced in the rotor, so the impedance is very low and the current drawn from the supply can be five to seven times the full-load current.

This high inrush current can cause undesirable effects such as:

- Voltage dips in the supply system,
- Excessive heating of the windings,
- Mechanical stress on the rotor and shaft, and
- Disturbance to other electrical equipment connected to the same supply line.

To minimize these effects, reduced voltage starting methods are employed. In this technique, the supply voltage applied to the stator is reduced during starting, which in turn limits the starting current.

Common reduced-voltage starting methods include:

- **Star-Delta Starter** – The motor is initially connected in star configuration and later switched to delta after gaining speed.
- **Auto-Transformer Starter** – The supply voltage is reduced by an auto-transformer during starting and then restored to full voltage.
- **Stator Resistance Starter** – External resistances are inserted in the stator circuit to drop the voltage during starting.

The torque developed by an induction motor is proportional to the square of the applied voltage, i.e. $T \propto V^2$

This means that while the starting current reduces, the starting torque also decreases.

In the Reduced Voltage Running Up Test, the motor is started and allowed to run up to speed at various reduced voltages, and the speed, current, and torque are observed. By conducting this test, one can study the relationship between voltage, current, torque, and speed during the starting period.

The Reduced Voltage Running Up Test is performed to determine whether cogging or crawling effects are present in a three-phase induction motor during its starting period. These effects can cause the motor to fail to start or run at sub-synchronous speeds, which affects its performance. The test also provides valuable information about the vibration level and noise level of the motor under different voltage conditions. By analyzing these parameters, it becomes possible to assess the motor's mechanical and electrical behaviour during acceleration, ensuring smooth and reliable operation when connected to industrial loads.

VII Circuit Diagram:

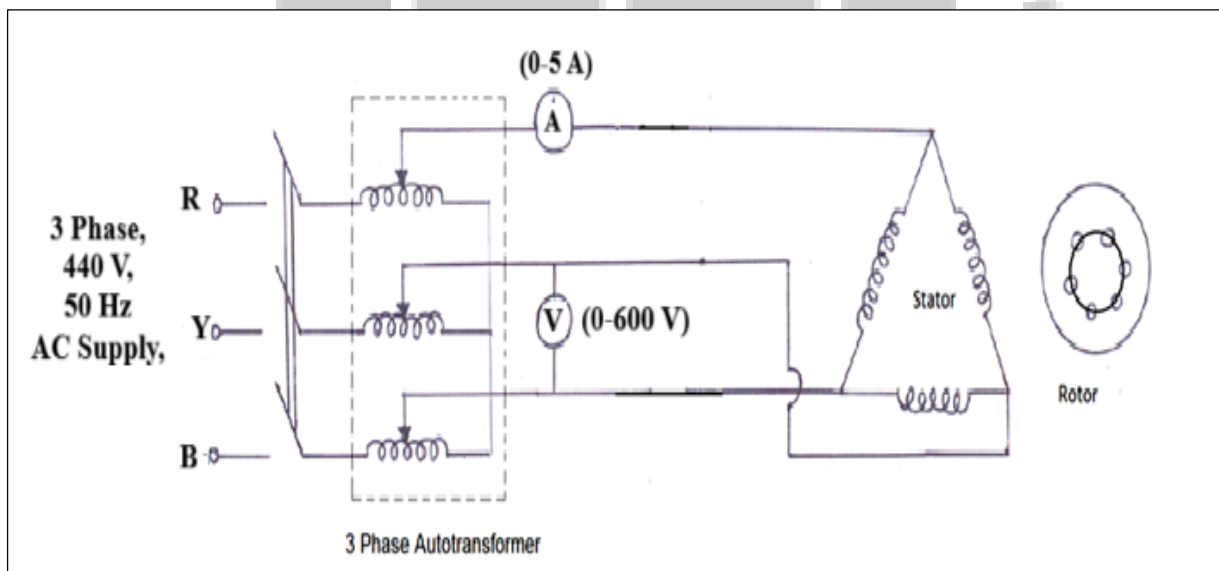

Fig.14.1: Reduced voltage running up test

VIII Required Resources/apparatus/equipment with specification.:

Sr. No.	Name of Equipment / Apparatus	Specification / Rating	Quantity
1	Three-phase induction motor	3-phase, 415 V, 50 Hz, 3/5 HP	1 No
2	Three-phase auto-transformer	0-440 V, 10 A (variable output)	1 No
3	Ammeter (Moving Iron Type)	0-10 A, AC	1 No
4	Voltmeter (Moving Iron Type)	0-500 V, AC	1 No
5	Tachometer	0-9999 r.p.m. (Contact type or non-contact type)	1 No

IX Precautions:

1. Ensure all connections are made correctly as per the circuit diagram before switching on the supply.
2. The supply voltage should be increased gradually using the auto-transformer.
3. Do not exceed the rated voltage of the motor during the test.
4. Avoid sudden changes in voltage to prevent mechanical stress on the motor shaft.
5. Keep all measuring instruments properly calibrated and connected in correct ranges.
6. Ensure the motor is properly earthed before starting the experiment.
7. Record all readings carefully to avoid experimental error.

X Procedures:

1. Make the connections as per the circuit diagram.
2. Start the motor and gradually increase the voltage up to $1/\sqrt{3}$ of the rated voltage using the auto-transformer.
3. Measure the voltage, current, and speed of the motor, and record the readings in the observation table.
4. Gradually increase the voltage up to the rated value of the motor.
5. Again, measure the voltage, current, and speed of the motor and enter the readings in the observation table.
6. Repeat the above procedure for the reverse direction of rotation of the motor.
7. After completing all readings, gradually reduce the voltage to zero and switch off the supply.

XI Observation Table:**a) Readings for Normal direction of Rotation:**

Parameter	$1/\sqrt{3}$ Rated Voltage(V)	Rated voltage
Voltage		
Current		
Speed (r.p.m.)		

b) Readings for Reverse direction of Rotation:

Parameter	$1/\sqrt{3}$ Rated Voltage(V)	Rated voltage
Voltage		
Current		
Speed (r.p.m.)		

XII Results

.....

.....

.....

XIII Interpretation of results:

.....

.....

.....

XIV Conclusion and recommendation:

.....

.....

.....

XV Practical related questions (Provide space for answers):

(Note: Below given are few sample questions for reference. Teachers must design more such questions so as to ensure the achievement of identified CO.)

1. Why is the reduced voltage running up test performed on a three-phase induction motor?
2. What is the effect of reducing the supply voltage on the starting torque of an induction motor?
3. What is cogging and crawling in an induction motor?
4. Give list of Routine tests and type tests of three-phase induction Motor.

.....

.....

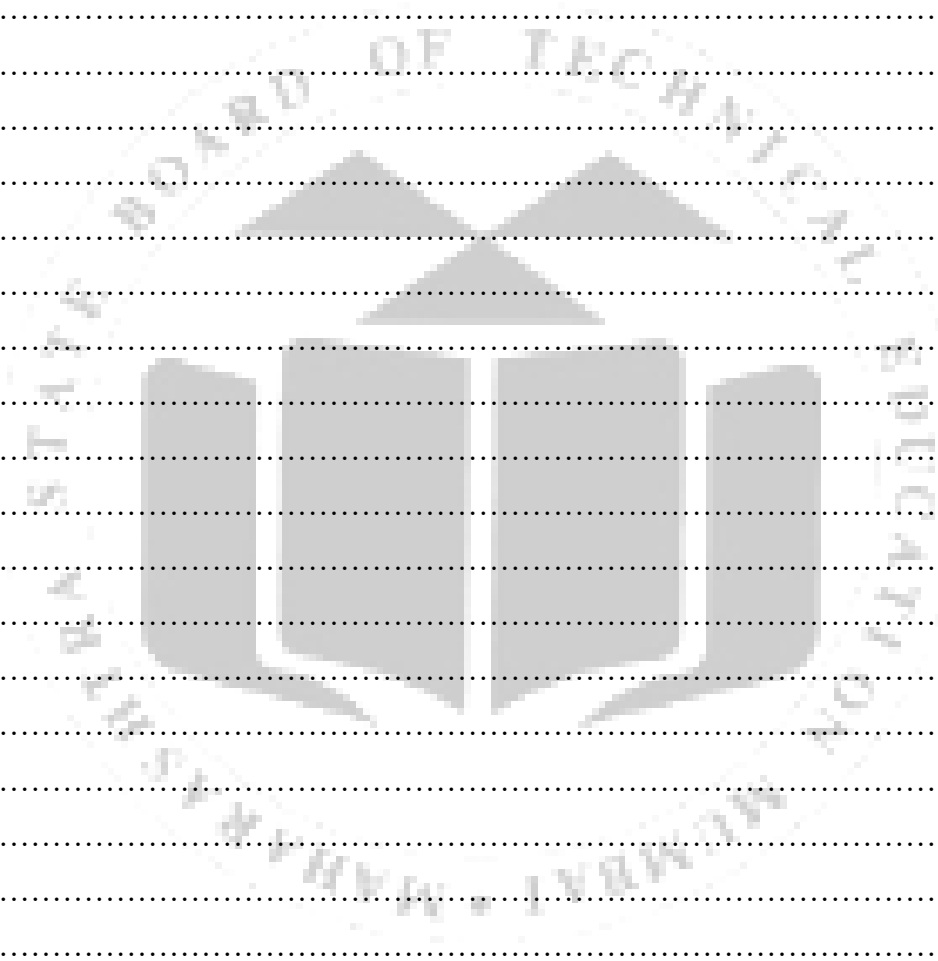

XVI References/Suggestions for further reading:

1. B.L. Theraja & A.K. Theraja, *A Textbook of Electrical Technology – Vol. II: AC & DC Machines*, S. Chand Publications, New Delhi.
2. J.B. Gupta, *Theory and Performance of Electrical Machines*, S.K. Kataria & Sons, New Delhi.
3. P.S. Bhimbra, *Electrical Machinery*, Khanna Publishers, New Delhi.

Assessment Scheme:

Performance Indicators		Weightage
Process Related: (15 Marks)		60%
1	Handling of the components	10 %
2	Identification of component	20 %
3	Measuring value using suitable instrument	20 %
4	Working in team	10 %
Product Related: (10 Marks)		40%
5	Identify theoretical values of given component from datasheets	10 %
6	Interpretation of result	05 %
7	Conclusions	05 %
8	Practical related questions	15 %
9	Submitting the journal in time	05%
Total (25 Marks)		100 %

Marks Obtained			Dated signature of Teacher
Process Related (15)	Product Related (10)	Total (25)	

Practical No.15: Measurement of phase winding resistance of a three-phase induction motor by V-I method. (before and after no load running).

I. Practical Significance:

To understand the method of determining the phase winding resistance of a three-phase induction motor using the V–I method. To study the effect of temperature on winding resistance before and after no-load running of the motor.

II. Industry/Employer Expected Outcome(s):

Students will be able to measure the DC resistance of motor windings accurately using suitable instruments. They will understand how temperature variations affect the electrical characteristics and performance of induction motors during operation.

III. Course Level Learning Outcome(s):

CO3 - Maintain rotating electrical machines.

IV. Laboratory Learning Outcome(s):

LLO 15.1 Test the insulation condition of three phase induction motor (before and after no load running).

V. Relevant Affective Domain Related Outcome(s):

Develops careful and safe working habits while performing electrical measurements on machines. Demonstrates responsibility in handling instruments and observing safety precautions during testing. Shows curiosity and initiative in analysing the effect of temperature on motor winding resistance.

VI. Relevant Theoretical Background:

The stator of a three-phase induction motor consists of three identical windings displaced by 120° electrically. Each winding has a certain amount of resistance, which depends on the length, cross-sectional area, and material (usually copper) of the conductor.

The phase winding resistance can be determined by applying a known DC voltage to the winding and measuring the resulting current. Using Ohm's Law, the resistance is calculated as:

$$R = \frac{V}{I}$$

Where, **V** is the applied DC voltage and **I** is the measured current.

Since the resistance of copper conductors increases with temperature, the winding resistance measured before running (cold condition) and after no-load running (hot condition) will differ. This difference helps to estimate the temperature rise in the motor winding and verify the quality of winding and cooling.

For copper, the temperature coefficient of resistance (α) is approximately 0.00393/°C, and the relationship between resistance and temperature is given by:

$$R_2 = R_1 [1 + \alpha(T_2 - T_1)]$$

Accurate measurement of winding resistance is important for determining copper losses, efficiency, and thermal behaviour of the motor during operation.

VII. Circuit Diagram:

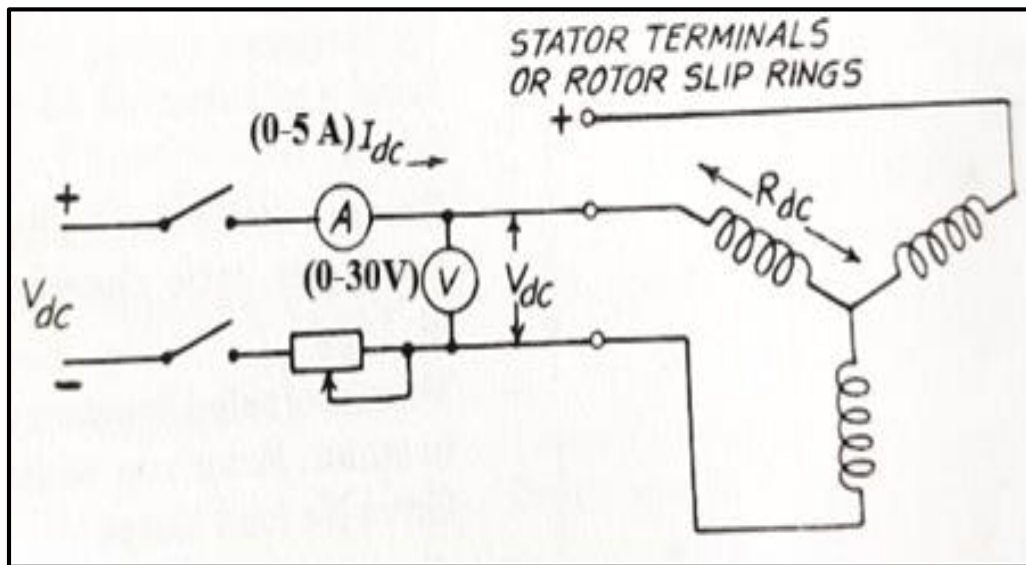

Figure 15.1: Measurement of resistance by using V-I Method

VIII. Required Resources/apparatus/equipment with specification.:

Sr. No.	Apparatus	Specification	Quantity
1	Three-phase induction motor	415 V, 50 Hz, 3/5 HP	1
2	DC power supply	0 – 30 V, variable	1
3	Ammeter	0 – 5 A, DC	1
4	Voltmeter	0 – 30 V, DC	1
5	Thermometer	0–100 °C range	1

IX. Precautions:

1. Ensure that the motor is completely disconnected from the three-phase AC supply before applying the DC source.
2. Use a low DC current to avoid unnecessary heating of the winding during measurement.
3. Check the proper polarity and range of meters before connecting.
4. All connections should be tight and free from loose contacts to prevent voltage drops or sparking.
5. Do not touch live terminals during the experiment; use insulated leads and tools.
6. Take hot resistance readings immediately after no-load running to avoid cooling errors.

- Allow sufficient cooling time before repeating tests if required.

X. Procedures:

A. Measurement Before No-load Running (Cold Test):

- Identify and mark the three stator phase terminals (U–V–W or R–Y–B).
- Connect the DC source, ammeter (in series), and voltmeter (across the winding under test).
- Apply a small DC voltage so that a current of about 1–5 A flows through the winding.
- Record the corresponding voltage and current readings.
- Repeat the measurement for all three phase windings.
- Calculate the resistance of each winding using $R = \frac{V}{I}$.

B. Measurement After No-load Running (Hot Test):

- Run the motor on three-phase supply under no-load condition for 15–30 minutes to heat up the windings.
- Disconnect the supply immediately and measure the resistance of each winding using the same V–I method.
- Record all readings carefully and calculate the resistance.
- Compare the cold and hot resistance values and note the percentage increase.

XI. Observation Table:

A. Before No-load Running (Cold Test):

Sr. No.	Phase	Voltmeter Reading (V) in Volt	Ammeter Reading (I) in Amp.	Calculated Resistance $R = \frac{V}{I}$ (Ω)	Average Resistance (Ω)
1.	R Phase				
2.	Y Phase				
3.	B Phase				

B. After No-load Running (Hot Test):

Sr. No.	Phase	Voltmeter Reading (V) in Volt	Ammeter Reading (I) in Amp.	Calculated Resistance $R = \frac{V}{I}$ (Ω)	Average Resistance (Ω)
1.	R Phase				
2.	Y Phase				
3.	B Phase				

XII. Calculation:

- For each winding calculate mean cold resistance R_{cold} and mean hot resistance R_{hot}
- Percentage increase in resistance: % increase = $\frac{R_{hot}-R_{cold}}{R_{cold}} \times 100 = \underline{\hspace{2cm}}$

The phase winding resistance of the three-phase induction motor measured by the V–I method is:

- Mean cold resistance of phase A: $R_{A(cold)} = \dots\dots\dots \Omega$
- Mean hot resistance of phase A: $R_{A(hot)} = \dots\dots\dots \Omega$
- Percentage increase.%

XIII. Results:

.....
.....
.....
.....

XIV. Interpretation of results:

.....
.....
.....
.....

XV. Conclusion and recommendation:

.....
.....
.....
.....

XVI. Practical related questions (Provide space for answers):

(Note: Below given are few sample questions for reference. Teachers must design more such questions so as to ensure the achievement of identified CO.)

1. What is the significance of measuring phase winding resistance in a three-phase induction motor?
2. Why should the resistance measurement be done both before and after no-load running?
3. What factors can cause variation in resistance among the three phases?
4. What does an increase in winding resistance indicate about the motor’s operating condition?

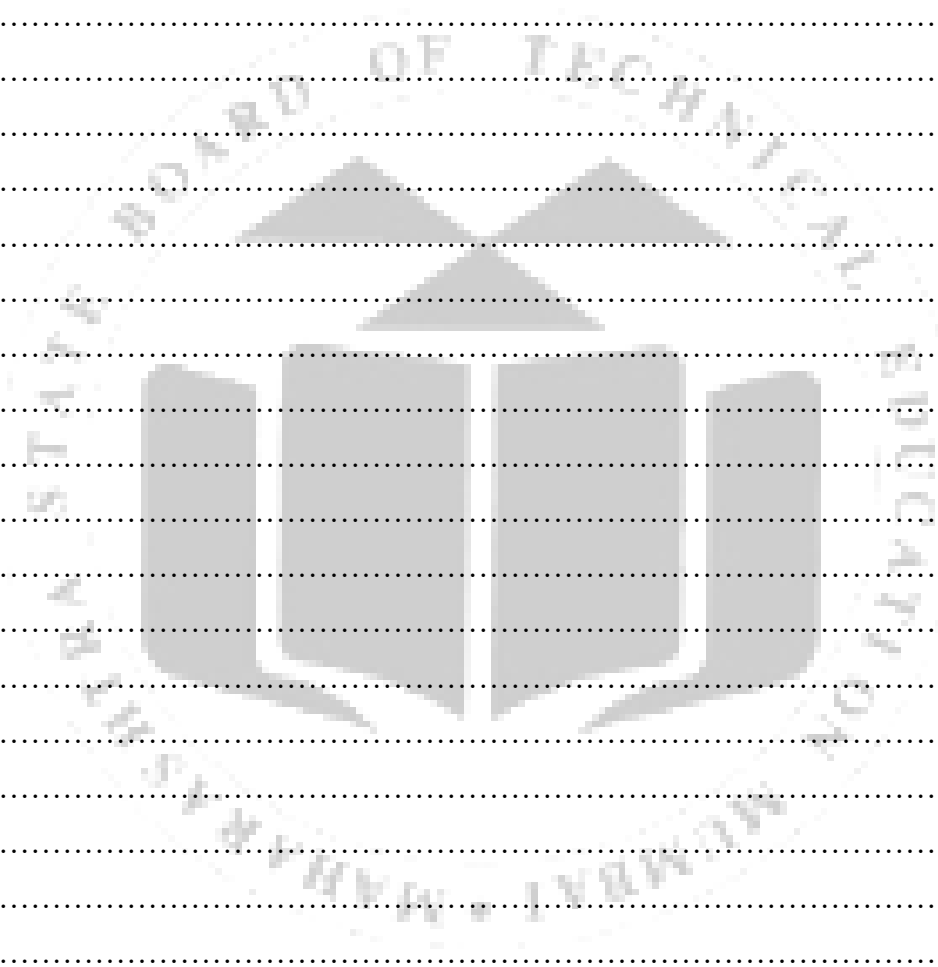

XVII. References/Suggestions for further reading:

- 1.Measurement of D.C. Resistance of a 3-phase Induction Motor - Deepakkumar Yadav
- 2.S.K. Bhattacharya, *Electrical Machines*, Tata McGraw-Hill Education.
- 3.Nagrath I.J. & Kothari D.P.,*Electric Machines*, Tata McGraw-Hill Education.

Assessment Scheme:

Performance Indicators		Weightage
Process Related: (15 Marks)		60%
1	Handling of the components	10 %
2	Identification of component	20 %
3	Measuring value using suitable instrument	20 %
4	Working in team	10 %
Product Related: (10 Marks)		40%
5	Identify theoretical values of given component from datasheets	10 %
6	Interpretation of result	05 %
7	Conclusions	05 %
8	Practical related questions	15 %
9	Submitting the journal in time	05%
Total (25 Marks)		100 %

Marks Obtained			Dated signature of Teacher
Process Related (15)	Product Related (10)	Total (25)	

Practical No.16: Measurement of phase winding resistance of a three-phase induction motor by V-I method. (before and after conducting brake test)

I. Practical Significance:

This practical helps to understand the variation of stator winding resistance with temperature, which directly affects the motor's performance and efficiency. It demonstrates how to accurately measure phase winding resistance using the V–I method and apply temperature correction to obtain true resistance at standard conditions (20°C).

II. Industry/Employer Expected Outcome(s):

Students can accurately measure phase winding resistance and assess the effect of temperature on motor performance. Develop practical skills needed for motor testing, troubleshooting, and preventive maintenance in industrial settings.

III. Course Level Learning Outcome(s):

CO3 - Maintain rotating electrical machines

IV. Laboratory Learning Outcome(s):

LLO 16.1 Test the insulation condition of three phase induction motor (before and after conducting brake test).

V. Relevant Affective Domain Related Outcome(s):

Develops carefulness, responsibility, and safety conscious behaviour while handling electrical machines and measuring instruments. Enhances observation, recording, and analytical skills to interpret practical results effectively.

VI. Relevant Theoretical Background:

•V–I Method of Resistance Measurement:

The phase winding resistance of a three-phase induction motor can be measured using DC voltage and measuring the resulting current through the winding.

- According to Ohm's Law:

$$R = \frac{V}{I}$$

where **V** is the applied DC voltage and **I** is the measured current.

- Temperature Effect on Resistance:
- Copper winding resistance increases with temperature.
- Temperature correction formula:

$$R_{20} = \frac{R_T}{1 + \alpha(T - 20)}$$

where,

- R_T = measured resistance at temperature T °C
- R_{20} = resistance at 20 °C
- $\alpha = 0.00393/^\circ\text{C}$ for copper

Before and After Brake Test:

- The brake test heats the motor, increasing winding resistance. Measuring resistance before and after the brake test helps to understand the effect of load and temperature on motor winding resistance. Accurate knowledge of phase winding resistance is essential for motor protection, efficiency analysis, and fault detection. The V–I method is widely used in labs and industry because of its simplicity and reliability for low-resistance measurement.
- The brake test is a method to load the motor mechanically and measure torque, power, or efficiency. Running the motor under load increases winding temperature, thereby increasing measured resistance. Measuring before and after the brake test shows the effect of load and heating on winding resistance.

VII. Circuit Diagram:

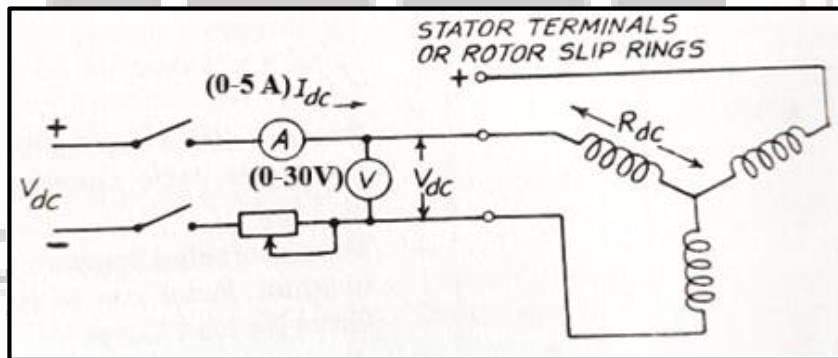

Fig. 16.1 : Measurement of resistance by using V-I Method

VIII. Required Resources/apparatus/equipment with specification.:

Sr. No.	Apparatus	Specification	Quantity
1	Three-phase induction motor	415 V, 50 Hz, 3/5 HP	1
2	DC power supply	0 – 30 V, variable	1
3	Ammeter	0 – 5 A, DC	1
4	Voltmeter	0 – 30 V, DC	1

IX. Precautions:

1. Ensure all connections are tight and properly insulated before applying any current.
2. Keep motor disconnected from AC supply during DC test.
3. Apply low DC voltage to avoid heating.
4. Avoid prolonged DC excitation.
5. Record readings quickly after brake test before cooling

X. Procedures:

Part A. Before Brake Test

1. Ensure motor is isolated from AC supply.
2. Connect DC supply, ammeter, and rheostat in series with R-phase winding; connect voltmeter across winding.
3. Keep other windings open.
4. Apply small DC voltage and measure current.
5. Record voltage, current, and winding temperature.
6. Repeat for Y and B phases.

Part B. After Brake Test

1. Run the motor under load using the brake test.
2. Immediately measure V–I for all three phases.
3. Record increased winding temperature and corresponding voltage and current.

XI. Observation Table:

Part A Before Brake Test:

Sr. No.	Phase	Voltmeter Reading (V) in Volt	Ammeter Reading (I) in Amper	Calculated Resistance R = V/I (Ω)	Temp T ₁ (°C)
1.	R				
2.	Y				
3.	B				

Part B After Brake Test:

Sr. No.	Phase	V (V)	I (A)	R = V/I (Ω)	Temp T ₂ (°C)
1.	R				
2.	Y				
3.	B				

XII. Calculation:

Part A :

R-phase before brake test:

- $V = \text{___ V}, I = \text{___ A}$
- $R = V/I = \text{_____}$
- Temp (T) = ___ °C
- $R_{20} = \frac{RT}{1 + \alpha(T - 20)}, \alpha = 0.00393 / ^\circ\text{C}$

$R_{20} = \text{_____ } \Omega$

Part B :

R-phase After brake test:

- $V = \text{___ V}, I = \text{___ A}$
- $R = V/I = \text{_____}$
- Temp (T) = ___ °C
- $R_{20} = \frac{RT}{1 + \alpha(T - 20)}, \alpha = 0.00393 / ^\circ\text{C}$

$R_{20} = \text{_____ } \Omega$

XIII. Results:

.....
.....
.....
.....

XIV. Interpretation of results:

.....
.....
.....
.....

XV. Conclusion and recommendation:

.....
.....
.....

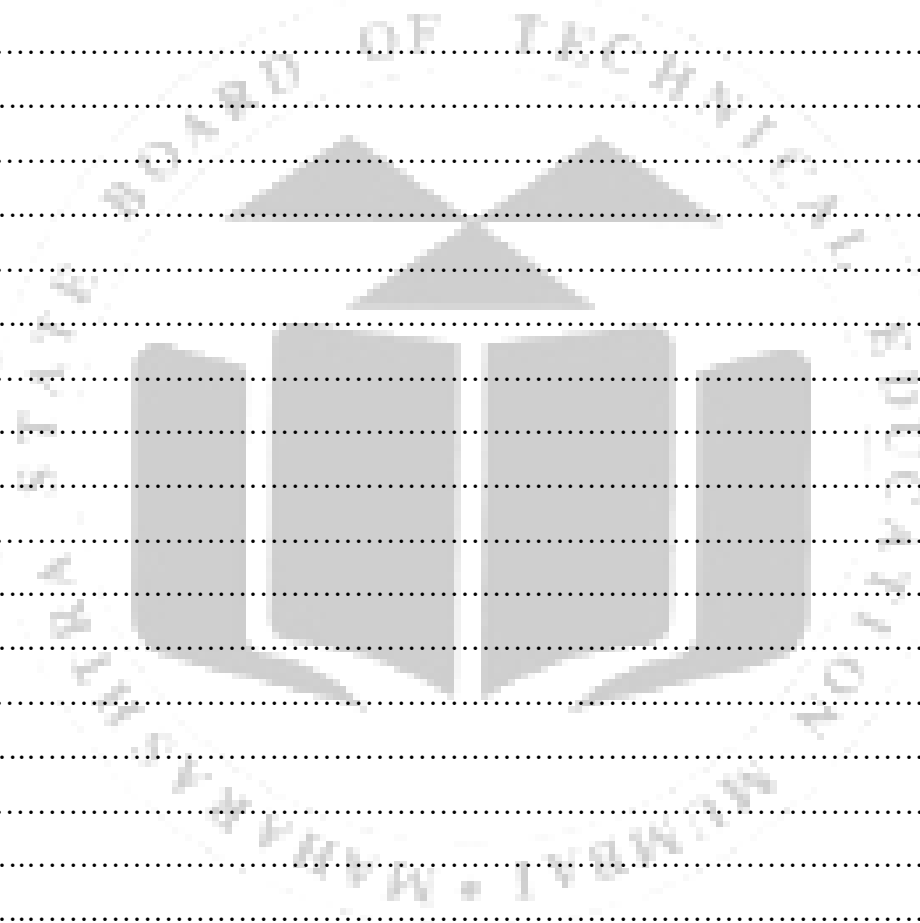

XVII. References/Suggestions for further reading:

- 1.Measurement of D.C. Resistance of a 3-phase Induction Motor - Deepakkumar Yadav
- 2.S.K. Bhattacharya, *Electrical Machines*, Tata McGraw-Hill Education.
- 3.Nagrath I.J. & Kothari D.P.,*Electric Machines*, Tata McGraw-Hill Education.

Suggested Assessment Scheme:

Performance Indicators		Weightage
Process Related: (15 Marks)		60%
1	Handling of the components	10 %
2	Identification of component	20 %
3	Measuring value using suitable instrument	20 %
4	Working in team	10 %
Product Related: (10 Marks)		40%
5	Identify theoretical values of given component from datasheets	10 %
6	Interpretation of result	05 %
7	Conclusions	05 %
8	Practical related questions	15 %
9	Submitting the journal in time	05%
Total (25 Marks)		100 %

Marks Obtained			Dated signature of Teacher
Process Related (15)	Product Related (10)	Total (25)	

Practical No.17: Phasing out test of the three-phase transformer.

I. Practical Significance:

The phasing out test ensures the correct phase sequence and polarity between the primary and secondary windings of a three-phase transformer.

II. Industry/Employer Expected Outcome(s):

The students can correctly identify the phase sequence and polarity of three-phase transformers, ensuring safe and efficient operation. Reduces the risk of equipment damage, short circuits, or operational failures when transformers are connected in parallel or to three-phase systems.

III. Course Level Learning Outcome(s):

CO4 - Maintain single phase and three phase transformers.

IV. Laboratory Learning Outcome(s):

LLO 17.1 Identify primary and relevant secondary windings of transformer.

V. Relevant Affective Domain Related Outcome(s):

Develops safety consciousness while handling three-phase transformers and electrical equipment. Encourages careful observation, accuracy, and disciplined working habits during practical tests.

VI. Relevant Theoretical Background:

The phasing out test is conducted to identify the corresponding primary and secondary winding terminals of the same phase in a three-phase transformer. This test is essential to ensure the correct phase sequence and polarity, which is crucial when transformers are connected in parallel or to a three-phase system. In this test, a small direct current (DC) is passed through one of the primary windings while a galvanometer is connected across one of the secondary windings, and the remaining primary and secondary windings are short-circuited. A momentary deflection in the galvanometer on making or breaking the primary current confirms that the selected secondary winding corresponds to the chosen primary winding. The test is repeated for all other windings to identify all corresponding terminals. High-voltage terminals are marked with uppercase letters (H1, H2, H3), while low-voltage terminals are marked with lowercase letters (a1, b1, c1). When viewed from the H.V. side, terminals are arranged in alphabetical order from left to right, with the neutral terminal, if provided, placed on the extreme left. Correct identification of terminals ensures safe and efficient transformer operation by preventing short circuits, circulating currents, and incorrect phase connections.

VII. Circuit Diagram:

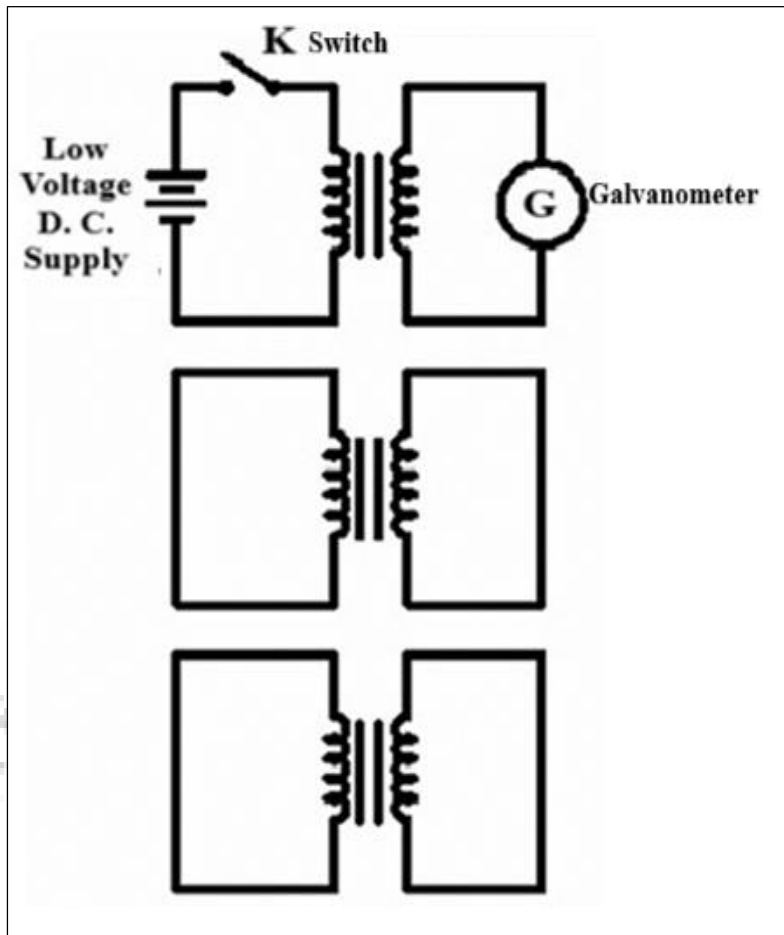

Fig. 17.1: Phasing out Test

VIII. Required Resources/apparatus/equipment with specification.:

Sr. No.	Equipment / Apparatus	Specification / Details	Quantity
1	Three-phase Transformer	400V/230V, 50 Hz, 3-phase transformer (suitable output in range of 2 kVA to 4 kVA)	1 No
2	DC Power Supply	0–12 V DC, 1–2 A	1 No
3	Galvanometer	0–1 mA, suitable for DC measurement	1 No
4	Switch / Key	Rated for applied voltage / DC	1 No

IX. Precautions:

1. Ensure all connections are tight and properly insulated before applying any current.
2. Use a low DC voltage to avoid damage to the transformer or galvanometer.

Maintenance of Electrical Equipments (316328)

3. Short-circuit the remaining primary and secondary windings as per procedure to prevent unwanted currents.
4. Do not touch live terminals or connections during the test; always use insulated tools and gloves.
5. Make and break the DC circuit slowly to avoid sudden high currents.
6. Ensure the galvanometer is properly rated for the DC current to prevent damage.
7. Keep a safe distance and use protective equipment (gloves, goggles, and mats).
8. Verify the correct orientation of terminals before starting the test to avoid errors.

X. Procedures:

1. Make the connection as per circuit diagram.
2. Identify the primary (H.V.) and secondary (L.V.) terminals of the transformer.
3. Short all the remaining primary and secondary windings using low-resistance wires.
4. Connect the galvanometer across one of the secondary windings.
5. Press the key “K” to allow DC to flow through the selected primary winding and observe the galvanometer deflection carefully.
6. Move the galvanometer to the next secondary winding and repeat the observation.
7. The secondary winding showing maximum deflection corresponds to the primary winding to which the DC supply is connected.
8. Repeat steps 2–6 for the other primary windings to identify their respective corresponding secondary windings.

XI. Observation Table:

Sr. No.	D.C. supply given to primary winding	Deflection of Galvanometer observed between secondary terminals.			Remarks
		Deflection across first secondary	Deflection across second secondary	Deflection across third secondary	
1.	P1				
2.	P2				
3.	P3				

XII. Results:

.....

.....

.....

.....

XIII. Interpretation of results:

.....

.....

.....

.....

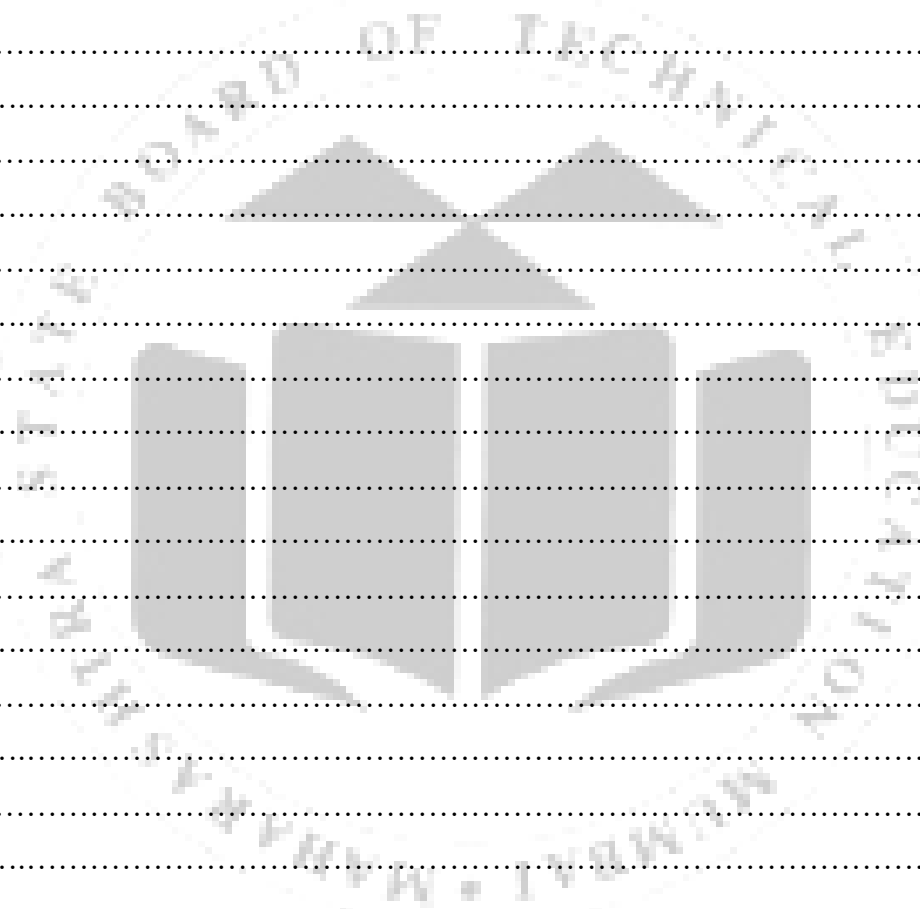

XVI. References/Suggestions for further reading:

1. The phasing out test on a three-phase transformer is carried.
2. Phasing Out Test Carried Out on Transformer.
3. Mittle & Mittal, *Electrical Machines*, McGraw-Hill Education.
4. <https://eepower.com/technical-articles/visualizing-transformer-behavior-drawing-phasor-diagrams-and-equivalent-circuits/#>

Assessment Scheme:

Performance Indicators		Weightage
Process Related: (15 Marks)		60%
1	Handling of the components	10 %
2	Identification of component	20 %
3	Measuring value using suitable instrument	20 %
4	Working in team	10 %
Product Related: (10 Marks)		40%
5	Identify theoretical values of given component from datasheets	10 %
6	Interpretation of result	05 %
7	Conclusions	05 %
8	Practical related questions	15 %
9	Submitting the journal in time	05%
Total (25 Marks)		100 %

Marks Obtained			Dated signature of Teacher
Process Related (15)	Product Related (10)	Total (25)	

Practical No.18: Polarity Test of Three Phase Transformer.

I. Practical Significance:

To verify the polarity of transformer terminals to ensure correct phase relationship between primary and secondary windings. To prevent destructive circulating currents and faults during parallel operation or interconnection of transformers.

II. Industry/Employer Expected Outcome(s):

To verify the polarity of transformer terminals to ensure correct phase relationship between primary and secondary windings. To prevent destructive circulating currents and faults during parallel operation or interconnection of transformers.

III. Course Level Learning Outcome(s):

CO4 - Maintain single phase and three phase transformers.

IV. Laboratory Learning Outcome(s):

LLO 18.1 Identify the polarity of transformer windings.

V. Relevant Affective Domain Related Outcome(s):

Develops a safety-conscious attitude while working with high-voltage transformer terminals. Encourages responsibility and precision in identifying correct polarity before making electrical connections.

VI. Relevant Theoretical Background:

In two winding transformers, one terminal is positive with respect to the other terminal. The polarity of the transformer mentions the relative direction of the induced voltage between the HV and LV windings. In practical transformers, the leads are coming out from the terminals of windings. The polarity of a transformer refers to the way by which the leads are brought out from the transformer.

The polarity of a transformer is important in many aspects. And it is necessary to have the knowledge of polarity while following operations on transformers;

- To connect the instrument transformer (CT and PT) for measuring purposes.
- To connect the protective relays with the transformer.
- To construct a three-phase transformer.
- To connect an extra transformer with an existing transformer in parallel.

In to better understand, always put H1 and H2 or X1 & X1 marking instead of dot marking while finding the polarities of winding terminals. In this case, H1 and H2 marking are used for primary (High Voltage) and H2 for secondary voltage and same is the case for X1 and X2 making.

Polarity of Transformer

To mention the polarity in transformer windings, the dot convention of a transformer method is used.

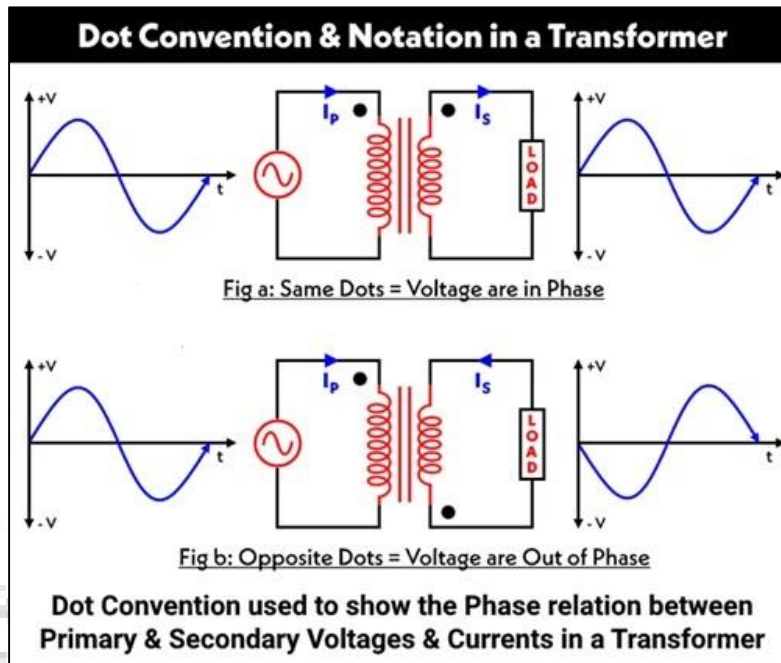

Fig. 18.1: Dot Convention & Notation in a Transformer

In the above figure-a, two dots are shown on the same side of primary and secondary windings. Hence, the current entering the primary side dot is in the same direction as the current leaving the secondary side dot. It means the polarity of the voltages at the dotted ends is in phase. Therefore, if the voltage is positive at a dotted point in the primary winding, the voltage will be positive in the secondary winding also. As shown in figure-b, two dots are on opposite sides. In this condition, the windings of transformers are wound in opposite directions on the core. Hence, the polarity of the voltages at a dotted point is out of phase. So, if the voltage is positive at a dotted point in the primary winding, the voltage will be negative in the secondary winding. The polarity of a transformer can be additive or subtractive. To find the additive or subtractive polarity, connect one terminal of primary winding with one terminal of the secondary winding and connect the remaining terminals of primary and secondary winding with a voltmeter.

Additive Polarity:

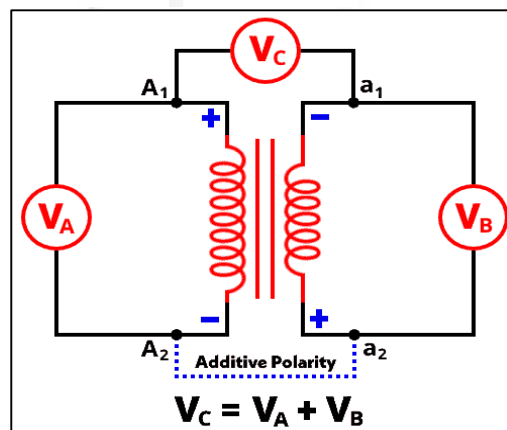

Fig. 18.2: Additive Polarity

In additive polarity, the voltmeter reads the voltage of summation of primary and secondary voltages. The voltmeter reading is denoted as VC. And the primary and secondary voltage is denoted as VA and VB respectively. In additive polarity, the voltmeter reads;

$$V_C = V_A + V_B$$

Subtractive Polarity

In subtractive polarity, the voltmeter reads the voltage of subtraction of primary and secondary voltages. The voltmeter reading is denoted by VC and the equation of voltmeter reading is;

$$V_C = V_A - V_B$$

The circuit diagram of subtractive polarity is shown in the figure below.

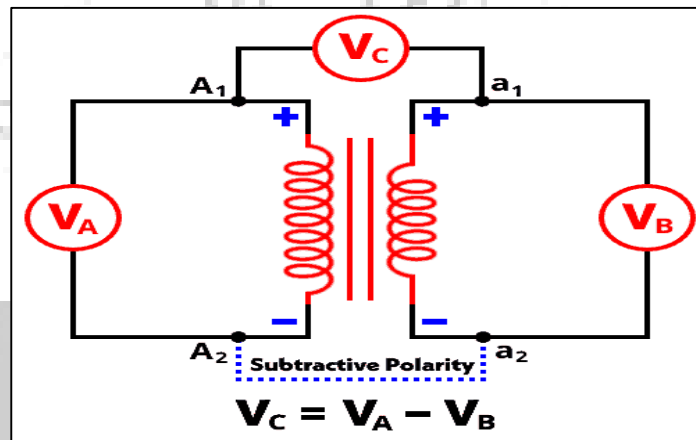

Fig.18.3 : Subtractive Polarity

VII. Circuit Diagram:

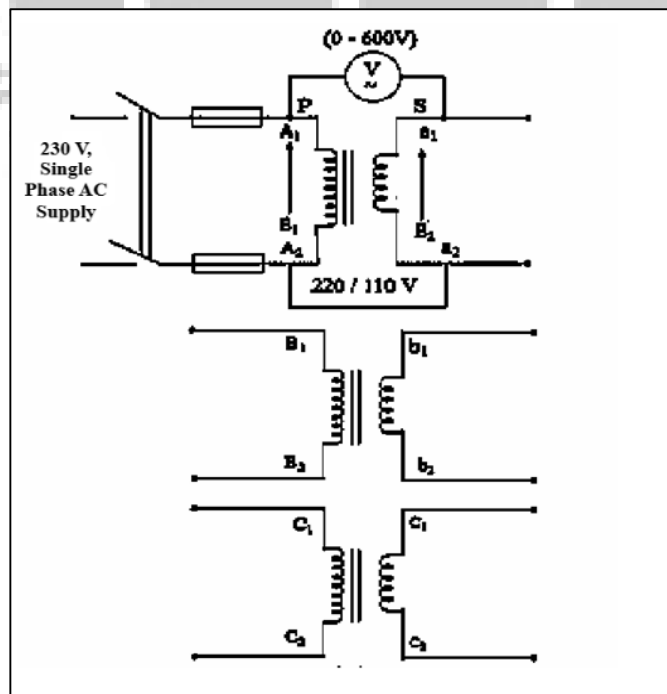

Fig18.4: Polarity Test

VIII. Required Resources/apparatus/equipment with specification.:

Sr. No.	Equipment / Apparatus	Specification / Rating	Quantity
1.	Three-Phase Transformer	400V/230V, 50 Hz, 3-phase transformer (suitable output in range of 2 kVA to 4 kVA)	1 No
2.	Auto-transformer / Variac	Single phase auto transformer 0-270 V, 15 A, input single phase, 230 V.	1 No
3.	Voltmeter (AC)	0-600V (Digital/Analog)	3 Nos.
4.	Multimeter	AC Voltage Range	1 No

IX. Precautions:

1. Ensure all connections are tight and correct before switching ON the supply.
2. Apply low voltage initially using a Variac/Auto-transformer to avoid damage in case of wrong polarity connection.
3. Do not touch live terminals while the test is in progress.
4. Use properly rated voltmeters and insulated test leads for accurate and safe measurement.
5. Disconnect the transformer from any external load before performing the polarity test.
6. Switch off the supply immediately if abnormal noise, sparking, or overheating is observed.
7. Ground/Earth the transformer body properly to avoid electric shock

X. Procedures:

1. Make the connections as per the circuit diagram.
2. Identify and mark the primary terminals as A1 and A2.
3. Connect **A2** (primary) and **a2** (secondary) using a low-resistance wire.
4. Keep the other phase terminals **B1, B2, C1, C2** open.
5. Apply a suitable low voltage across the primary winding using a Variac/Auto-transformer.
6. Measure the primary voltage (V_1), secondary voltage (V_2), and series voltage across the voltmeter.
7. If the voltmeter reading is approximately $V_1 - V_2$, then A2 and a2 are of the **same polarity**.
8. If the voltmeter reading is approximately $V_1 + V_2$, then A2 and a2 are of **opposite polarity**.
9. Switch OFF the supply.
10. Repeat the same procedure for the remaining phases of the transformer.

XI. Observation Table:

Sr. No.	Name of Phase	Primary Voltage (V_1) in Volt	Secondary Voltage (V_2) in Volt	Voltage Across Series Combination ($V_1 + V_2$ or $V_1 - V_2$)	Observed Polarity (Additive/Subtractive)
1.	R - Phase				
2.	Y - Phase				
3.	B - Phase				

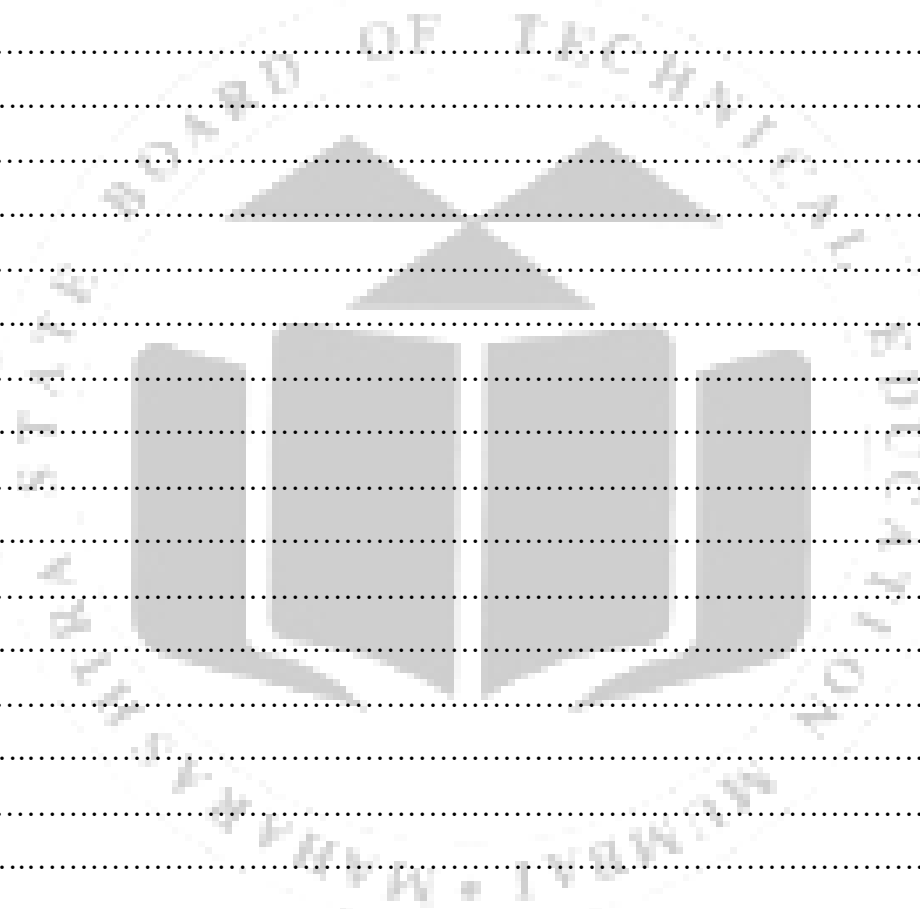

XVI. References/Suggestions for further reading:

1. Polarity Test of Transformer - Additive & Subtractive Polarity.
2. “Electrical Technology” – B.L. Theraja
3. Theory and performance of Electrical Machines - J.B. Gupta

Suggested Assessment Scheme:

Performance Indicators		Weightage
Process Related: (15 Marks)		60%
1	Handling of the components	10 %
2	Identification of component	20 %
3	Measuring value using suitable instrument	20 %
4	Working in team	10 %
Product Related: (10 Marks)		40%
5	Identify theoretical values of given component from datasheets	10 %
6	Interpretation of result	05 %
7	Conclusions	05 %
8	Practical related questions	15 %
9	Submitting the journal in time	05%
Total (25 Marks)		100 %

Marks Obtained			Dated signature of Teacher
Process Related (15)	Product Related (10)	Total (25)	

Practical No.19: Back-to-Back test on two identical single-phase Transformers.

I. Practical Significance:

This test enables determination of full-load copper losses and efficiency of a transformer without actually loading it, thus saving power and equipment. It allows simultaneous testing of two transformers under full-load conditions while only consuming losses from the supply, making it economical and practical.

II. Industry/Employer Expected Outcome(s):

Students should be able to test transformers safely and efficiently using minimum **resources**. Ability to analyze transformer performance data and evaluate loss components for energy efficiency improvement.

III. Course Level Learning Outcome(s):

CO4 - Maintain single phase and three phase transformers.

IV. Laboratory Learning Outcome(s):

LLO 19.1 Apply regenerative method of testing.

V. Relevant Affective Domain Related Outcome(s):

Develop discipline and safety consciousness while handling electrical equipment. Promote teamwork and responsibility during experimental setup and observation recording.

VI. Relevant Theoretical Background:

Transformer losses consist of core (iron) losses due to hysteresis and eddy currents, and copper losses due to winding resistance. In Back-to-Back (Sumpner's) Test, two identical transformers are connected such that:

Primaries are connected in parallel to rated supply → Both cores experience normal working flux → Core losses occur.

Secondaries are connected in series opposition → When rated current is forced to circulate in secondary loop, equivalent current flows in primaries → Copper losses are developed. By measuring the wattmeter readings, core and copper losses are separated, and efficiency at different load and power factors can be calculated without actually connecting a large load.

VII. Circuit Diagram:

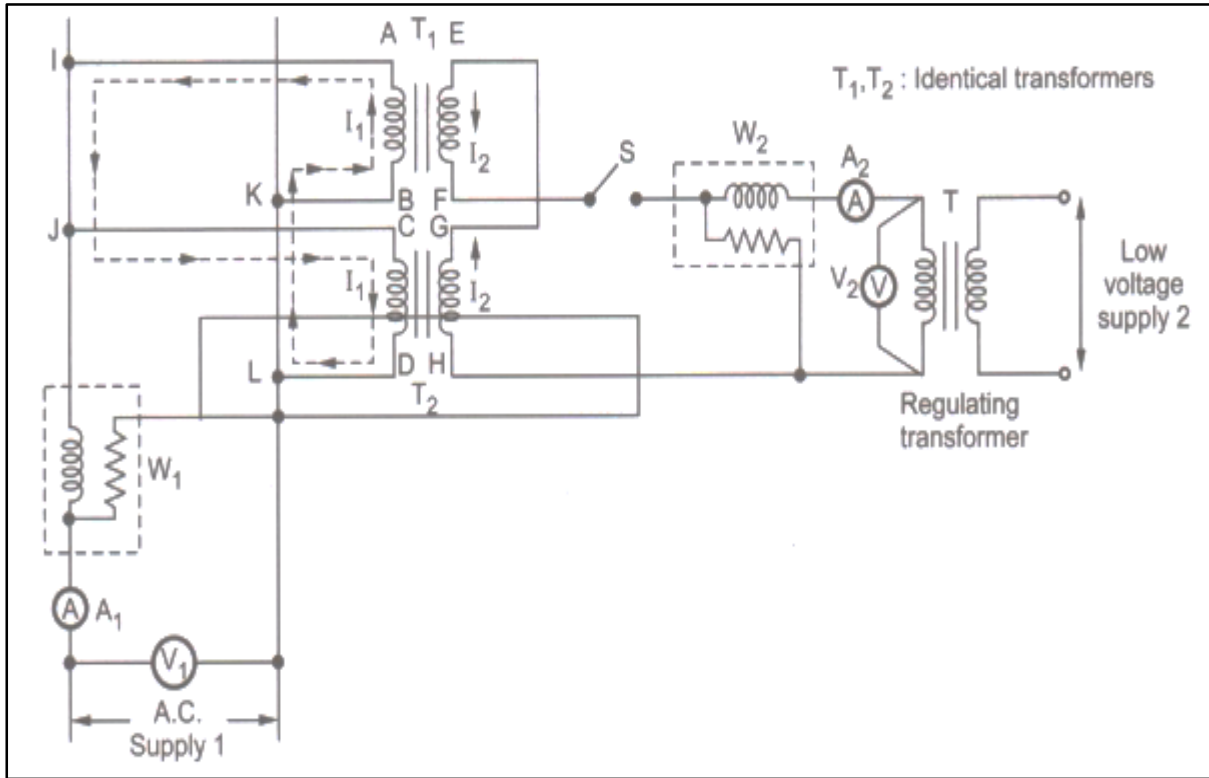

Fig. 19.1 Back-to-Back test on two single phase transformers

VIII. Required Resources/apparatus/equipment with specification.

Sr. No.	Equipment / Component	Specification / Rating	Quantity
1	Single-Phase Transformers	Identical, e.g. 230V/115V, 1 kVA	2
2	AC Supply / Autotransformer	0–230V, Single Phase	1
3	Wattmeter (LPF Type)	0–300V, 0–5A	2
4	Ammeter	0–5A AC	2
5	Voltmeter	0–300V AC	1
6	Connecting Wires	Insulated, Suitable Rating	As required

IX. Precautions:

1. Ensure correct polarity connection between transformer windings to avoid circulating current.
2. Never exceed rated current while forcing circulation through secondaries.
3. Use properly rated meters and wires to avoid overheating.
4. Switch ON/OFF supply gradually using Variac to prevent inrush current.
5. Ensure all connections are tight and properly insulated.

X. Procedures:

- Perform Open Circuit Test on one transformer to determine core loss at rated voltage.
- Connect primaries of both transformers T1 and T2 in parallel across AC supply.
- Connect secondaries in series opposition (polarity check required).
- Insert ammeter and wattmeter in primary side to measure input current and power.
- Switch ON supply and adjust to rated voltage across primaries.
- Gradually adjust load / secondary circuit until rated current flows.
- Record wattmeter readings, current, and voltage.
- Switch OFF supply and remove connections safely.
- Calculate core loss and copper loss, and determine efficiency.

XI. Observation Table:

Sr. no	Primary Voltage (V ₁)	Primary Current (I ₁)	Primary Power (W ₁)	Secondary Voltage (V ₂)	Secondary Current (I ₂)	Secondary power (W ₂)
1.						
2.						

XII. Calculation:

Iron loss per transformer $W_i = W_1 / 2 = \dots\dots\dots$ watts

Copper loss per transformer $W_{cu} = W_2 / 2 = \dots\dots\dots$ watts

$$\% \text{ Efficiency} = \frac{\text{Output Power}}{\text{Output Power} + \text{Losses}} \times 100$$

$$\% \text{ Efficiency} = \frac{\text{KVA} * \text{Cos } \phi * 10^3}{(\text{KVA} * \text{Cos } \phi * 10^3) + \text{Iron loss} + \text{Copper loss}} * 100$$

$= \dots\dots\dots * 100$

$= \dots\dots\dots\%$

$$\text{Regulation of each transformer} = \frac{\text{Voltage drop}}{\text{Secondary No load voltage}} * 100$$

$$\text{Regulation of each transformer} = \frac{\frac{V_2}{2}}{\text{Secondary No load voltage}} * 100$$

$= \dots\dots\dots * 100$

$= \dots\dots\dots\%$

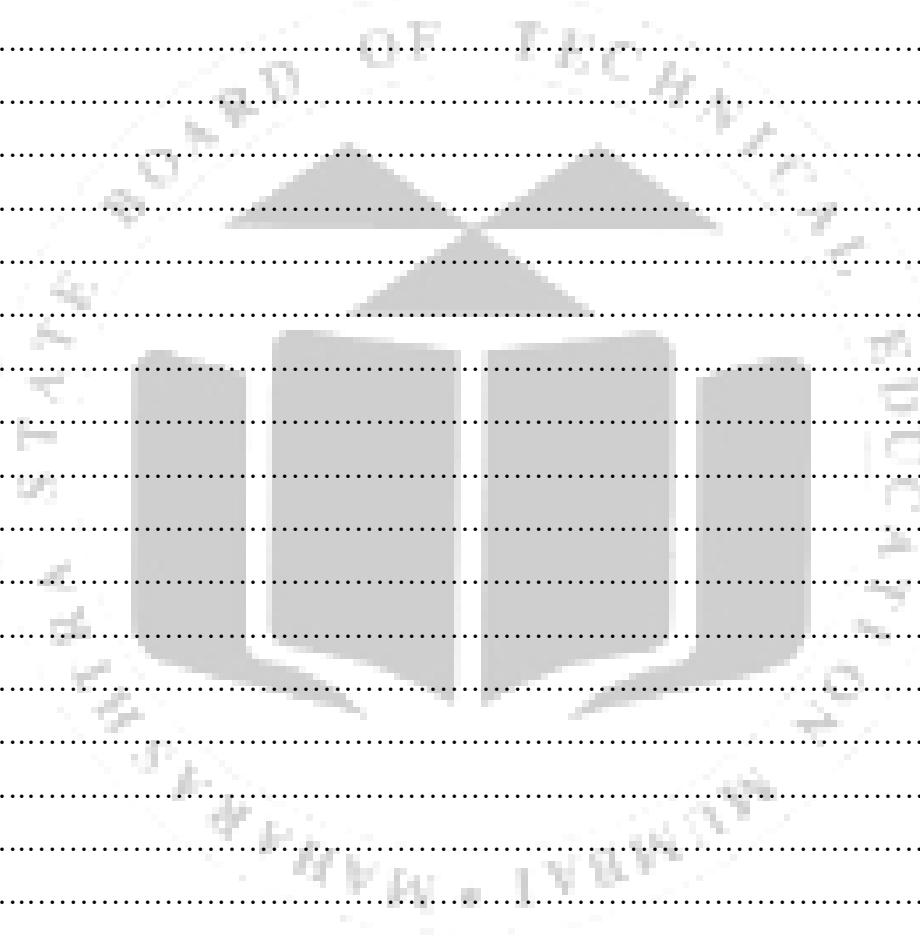

XVII. References/suggestions

1. <https://www.wazipoint.com/2022/06/transformer-back-to-back-or-sumpner.html>
2. <https://eee.poriyaan.in/topic/sumpner-s-test--back-to-back-test--11223/>

Assessment Scheme:

Performance Indicators		Weightage
Process Related: (15 Marks)		60%
1	Handling of the components	10 %
2	Identification of component	20 %
3	Measuring value using suitable instrument	20 %
4	Working in team	10 %
Product Related: (10 Marks)		40%
5	Identify theoretical values of given component from datasheets	10 %
6	Interpretation of result	05 %
7	Conclusions	05 %
8	Practical related questions	15 %
9	Submitting the journal in time	05%
Total (25 Marks)		100 %

Marks Obtained			Dated signature of Teacher
Process Related (15)	Product Related (10)	Total (25)	

Practical No.20: Dielectric strength test of transformer oil.

I. Practical Significance:

The dielectric strength test of transformer oil ensures that the insulation medium inside the transformer can safely withstand high voltages without breakdown. It helps in detecting contamination or moisture in the oil, preventing electrical failures and extending transformer life.

II. Industry/Employer Expected Outcome(s):

Employers expect students to accurately conduct dielectric strength testing and interpret results to determine whether transformer oil is fit for continued service.

III. Course Level Learning Outcome(s):

CO5 - Maintain insulation systems of electrical equipment.

IV. Laboratory Learning Outcome(s):

LLO 20.1 Test the dielectric strength of transformer oil.

LLO 20.2 Using transformer testing oil kit.

V. Relevant Affective Domain Related Outcome(s):

Learners develop a professional attitude towards preventive maintenance, understanding the importance of regular insulation testing in protecting transformer.

VI. Relevant Theoretical Background:

Insulating oil used in electrical power transformer is commonly known as transformer oil. It is normally obtained by fractional distillation and subsequent treatment of crude petroleum. That is why this oil is also known as mineral insulating oil. Transformer oil serves mainly two purposes one it is liquid insulation in electrical power transformer and second, it dissipates heat of the transformer i.e. acts as coolant. In addition to these, this oil serves other two purposes, it helps to preserve the core and winding as these are fully immersed inside oil and another important purpose of this oil is, it prevents direct contact of atmospheric oxygen with cellulose made paper insulation of windings, which is susceptible to oxidation.

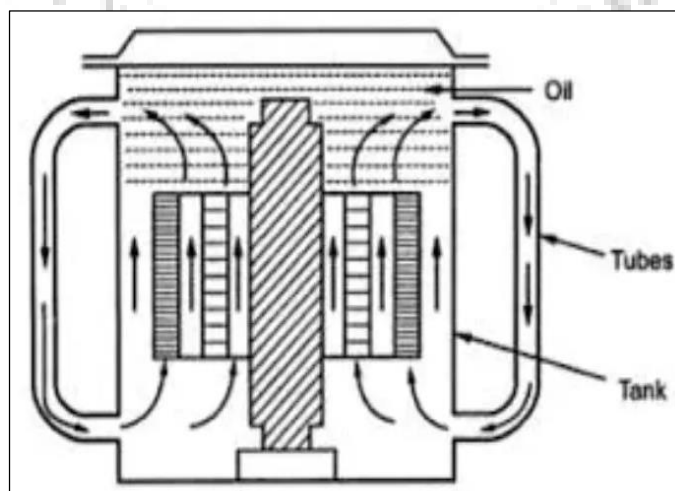

Figure19.1: Transformer

Types of Transformer Oil: –

Generally there are two types of transformer oil used in transformer,

1. Paraffin based transformer oil.
2. Naphtha based transformer oil.

Naphtha oil is more easily oxidized than paraffin oil. But oxidation product i.e. sludge in the Naphtha oil is more soluble than paraffin oil. Thus Sludge of naphtha-based oil is not precipitated in bottom of the transformer. Hence it does not obstruct convection circulation of the oil, means it does not disturb the transformer cooling system. But in the case of paraffin oil although oxidation rate is lower than that of Naphtha oil but the oxidation product or sludge is insoluble and precipitated at bottom of the tank and obstruct the transformer cooling system. Although Paraffin based oil has above mentioned disadvantage but still in our country it is generally used because of its easy availability. Another problem with paraffin-based oil is its high pour point due to the wax content, but this does not affect its use due to warm climate condition of India.

Properties of transformer Insulating oil: –

Some specific parameters of insulating oil should be considered to determine the serviceability of that oil.

Parameters of transformer oil

The parameters of transformer oil are categorized as,

1. Electrical Parameters: – Dielectric Strength, Specific resistance, Dielectric dissipation factor.
 1. Chemical Parameters: – Water content, acidity, sludge content.
 2. Physical Parameters: – Inter facial tension, viscosity, flash point, pour point.

Electrical Parameter of transformer oil: –

Dielectric Strength of transformer oil: -

Dielectric strength of transformer oil is known as breakdown voltage of transformer oil or BDV of transformer oil. Break down voltage is measured by observing at what voltage, sparking starts between two electrodes immersed in the oil, separated by specific gap.

Purpose of BDV Test of Transformer Oil

The breakdown voltage test (BDV test) is useful for;

- Predicting the remaining life of the transformer
- Enhancing operational safety
- Preventing equipment fires
- Maintaining transformer reliability.

VII. Circuit Diagram:

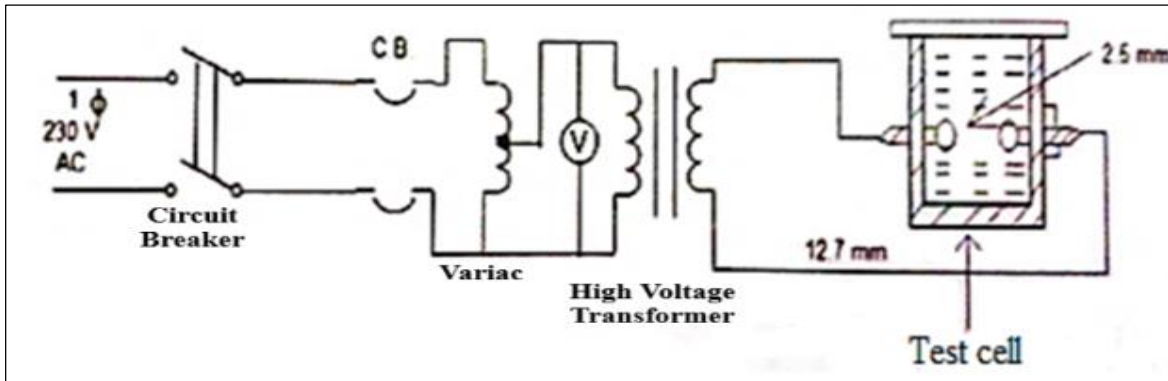

Figure 20.1 Dielectric Strength in Transformer oil

VIII. Required Resources/apparatus/equipment with specification.:

Sr. No.	Equipment / Resource	Specification / Details	Quantity
1	Transformer Oil Test Set	AC voltage 0–60 kV, voltage rise 2–5 kV/s, for 2.5 mm or 4 mm gap	1 No
2	Transformer Oil Samples	Fresh, dry, or used oil	As per Requirement

IX. Precautions:

1. Ensure the test equipment and electrodes are clean and dry before starting the test to avoid false readings.
2. Always wear insulating gloves and safety goggles to protect against electric shock and sparks.
3. Maintain the correct electrode gap (2.5 mm or 4 mm) as per standard to ensure accurate results.
4. Avoid touching the oil sample or electrodes while the voltage is being applied.
5. Perform the test in a well-ventilated area to prevent inhalation of any fumes from overheated oil.
6. Do not exceed the voltage rating of the test equipment.
7. If repeated testing is required, allow the oil to settle and bubbles to dissipate before the next test.
8. Keep a safe distance from the testing setup and ensure no unauthorized person is nearby.

X. Procedures:

1. Collect the 300-400 ml oil sample of transformer oil from the bottom valve of the transformer in a glass or plastic vessel.
2. Check the gap between the two electrodes of the machine and pour the oil sample in oil pot of the machine. (the gap between the two electrodes of the testing kit is generally 4mm)
3. Keep the oil pot in open air for 5 Minutes so that air bubble if any gets out. Further, the vessel should be disturbed to get out of the air bubbles and for homogeneous distribution of impurities.
4. Now put the oil sample in the machine.

Maintenance of Electrical Equipments (316328)

5. Increase the KV at the rate of 2 KV/Sec and observe the oil sample through a glass window.
6. Continuously observe the oil sample through an inspection window while increasing the voltage.
7. Note down the KV at which sparking is observed in the oil. The voltage at which sparking observed is the breakdown voltage of oil.
8. Repeat the step No. 5,6 and 7 for the same sample for three times and note down the breakdown KV in each case.
9. Take the average of BDV values observed in step 7 and 8.
10. If oil BDV value is above 30 KV, transformer oil is good. (As per IEC, the minimum breakdown voltage of transformer oil should be not less than 30 KV. The BDV of transformer oil does not depend on the voltage rating of the transformer. Minimum transformer BDV value for either 11 KV, 22 KV, 132 KV is the same. The minimum transformer oil BDV is 30 KV.)

XI. Observation Table:

Sr. No.	Input Voltage	Breakdown Voltage in kV	Mean of breakdown voltage
1.			
2.			
3.			

XII. Results:

.....

.....

.....

.....

XIII. Interpretation of results:

.....

.....

.....

XIV. Conclusion and recommendation:

.....

.....

.....

XVI. References/Suggestions for further reading:

1. <https://electricallab.in/electrical-machine-ii-lab/dielectric-strength-of-transformer-oil/>
2. <https://vp-dei.vlabs.ac.in/Dreamweaver/objective4.html>
3. <https://electrical-engineering-portal.com/wp-content/uploads/testing-transformer-oil-withstand-electrical-load.jpg>

Assessment Scheme:

Performance Indicators		Weightage
Process Related: (15 Marks)		60%
1	Handling of the components	10 %
2	Identification of component	20 %
3	Measuring value using suitable instrument	20 %
4	Working in team	10 %
Product Related: (10 Marks)		40%
5	Identify theoretical values of given component from datasheets	10 %
6	Interpretation of result	05 %
7	Conclusions	05 %
8	Practical related questions	15 %
9	Submitting the journal in time	05%
Total (25 Marks)		100 %

Marks Obtained			Dated signature of Teacher
Process Related (15)	Product Related (10)	Total (25)	

Practical No. 21: Test insulation resistance and dielectric strength of the windings of a single-phase induction motor

I. Practical Significance:

This practical helps evaluate the insulation health of motor windings to ensure safety and reliability. It enables early detection of faults like moisture or deterioration, supporting effective preventive maintenance.

II. Industry/Employer Expected Outcome(s)

- Ability to test insulation resistance and dielectric strength of motor windings using standard instruments.
- Capability to assess insulation health and identify possible faults or deterioration.
- Ensures adherence to electrical safety and maintenance standards in industrial environments.
- Develops skills for preventive maintenance and reliable motor operation.

III. Course Level Learning Outcome(s)

CO5 - Maintain insulation systems of electrical equipment.

IV. Laboratory Learning Outcome(s)

LLO 21.1 Insulation resistance and dielectric strength of the windings in a single-phase induction Motor applying high-voltage, ensuring that the motor can withstand operational voltage without failure

V. Relevant Affective Domain related outcome(s)

The student demonstrates a responsible and safety-conscious attitude while performing insulation and dielectric strength tests. They handle testing instruments carefully and accurately, valuing the importance of preventive maintenance for reliable motor operation. The student also develops a positive outlook toward adhering to electrical safety standards and maintaining professional practices in the workplace.

VI. Relevant Theoretical Background (With diagrams if required)

In a single-phase induction motor, electrical insulation plays a crucial role in separating live conductors, such as the stator and rotor windings, from each other and from the motor frame. This insulation prevents short circuits, leakage currents, and accidental electric shocks, ensuring the safe and efficient operation of the motor.

Over time, the insulation may degrade due to various factors such as heat, moisture, mechanical stress, dust, vibration, and chemical contamination. As the insulation deteriorates, its resistance decreases, leading to leakage current and possible failure of the winding. Hence, periodic testing of insulation quality is necessary to assess the motor's health and reliability.

The insulation resistance test is conducted using an instrument called a megger (megohmmeter), which applies a high DC voltage (typically 500V or 1000V) across the winding and measures the resulting current.

The insulation resistance $R = \frac{V}{I}$ (in megaohms) indicates the condition of the winding insulation — a higher resistance signifies good insulation, while a low value indicates moisture or deterioration.

The dielectric strength test evaluates the ability of insulation to withstand high voltage without electrical breakdown. In this test, a gradually increasing AC or DC voltage is applied across the insulation until a specified level, ensuring it can endure normal and transient over voltages during operation.

A good understanding of Ohm’s Law, leakage current behaviour, dielectric breakdown, and properties of insulation materials (such as enamel, varnish, and paper) is essential. Safety precautions must be followed strictly, as high voltages are involved during these tests.

Thus, theoretical knowledge of electrical insulation principles, testing methods, and safety standards enables accurate evaluation of winding health and helps in implementing effective preventive maintenance in electrical machines.

VII. Actual Circuit diagram used in laboratory with equipment Specifications:

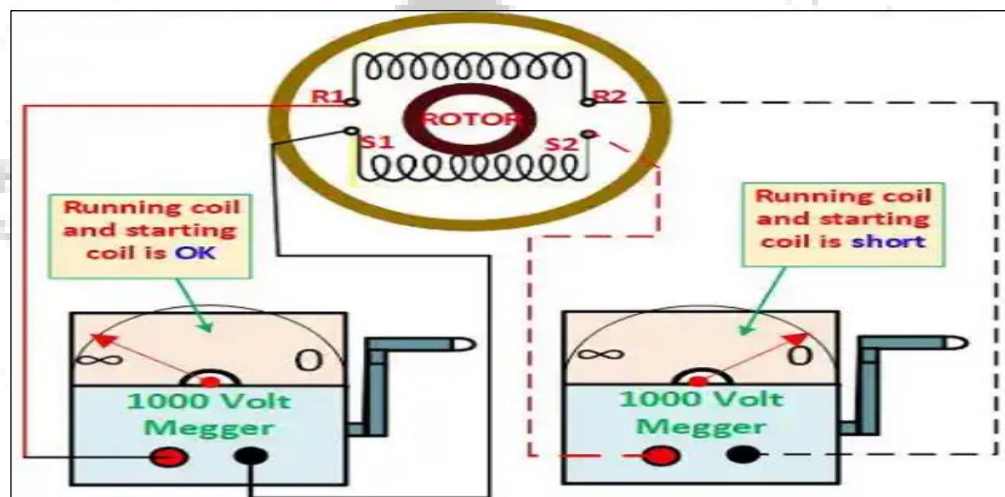

. Fig. 21.1 Insulation resistance test on single phase induction motor

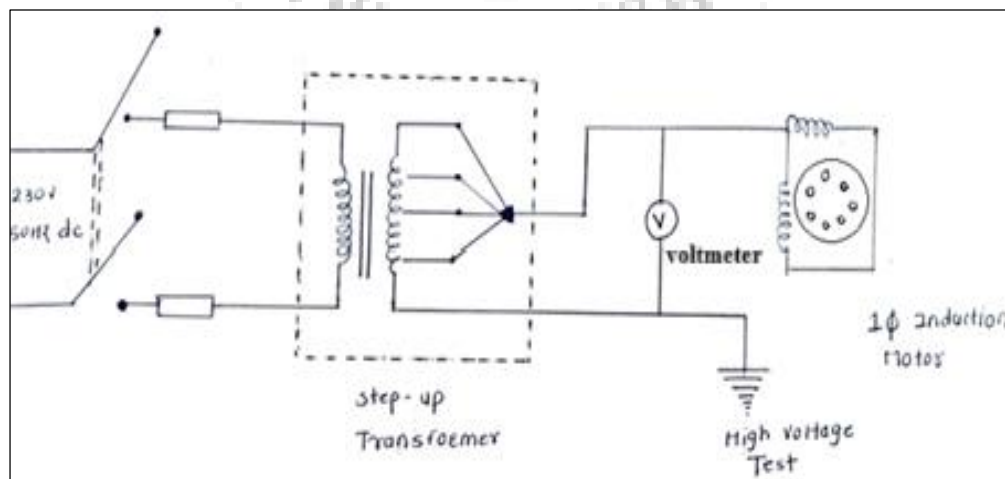

Fig. 21.2 Dielectric Strength Test

VIII. Required Resources/apparatus/equipment with specification:

Sr. No.	Name of Resource	Suggested Broad Specification	Quantity
1.	Megger	1000 V	01 No
2.	HV Tester	230 V/1000 V	01 No
3.	1-PH Induction motor	1 HP	01 No
4.	Connecting Probes	As per standard	-

IX. Precautions to be followed:

Insulation resistance test

- Ensure the motor is disconnected from the power supply.
- Clean and dry the motor terminals before testing.
- Use a megger with proper test voltage (usually 1000 V DC).
- Do not touch terminals or leads during the test.
- Test each winding separately from the frame and from each other.
- Apply test voltage only for a few seconds.
- Discharge the winding after testing.
- Record insulation resistance values properly.

Dielectric Strength Test

- Disconnect the motor from the power supply.
- Check test equipment and leads for insulation and calibration.
- Keep windings and terminals clean and dry.
- Use proper test voltage as per motor rating.
- Make firm and secure connections.
- Do not touch terminals during high-voltage testing.
- Increase voltage gradually and maintain for 1 minute.
- Stop test immediately if breakdown occurs.
- Discharge windings after testing.
- Keep the test area dry and isolated.

X. Procedure:

Insulation resistance Test

A. Insulation Test between Running Winding and Frame

1. Connect the megger red lead to the R1–R2 (main winding).
2. Connect the megger black lead to the motor frame (body).
3. Rotate the megger handle (or press the test button for digital type).
4. Note the insulation resistance value.
 - Expected Result: Insulation resistance should be greater than 1 MΩ (preferably above 5 MΩ).

B. Insulation Test between Starting Winding and Frame

1. Connect the megger red lead to the S1–S2 (starting winding).
2. Connect the megger black lead to the motor frame.
3. Operate the megger and read the resistance value.
 - Expected Result: Insulation resistance should again be greater than 1 MΩ.

C. Insulation Test between Running and Starting Windings

1. Connect the megger red lead to R1–R2 (main winding).
2. Connect the megger black lead to S1–S2 (starting winding).
3. Operate the megger and record the resistance value.
 - Expected Result: Insulation resistance should be high (above 1 MΩ), indicating proper insulation between both windings.

Dielectric Strength Test

- Make the connections as per diagram.
- Initially apply one third of test voltage at power frequency.
- Increase the voltage in steps of 5% of test voltage with time interval of ten seconds.
- Increase the voltage up to test value and maintain it for one minute.
- Reduce the voltage suddenly to one third of test voltage and switch off.

XI. Observations and calculations

01. Insulation resistance Test:

Sr. No.	Test Conducted	Terminals Connected	Measured Insulation Resistance (MΩ)	Remarks (OK/Fail)
1.	Running winding to Frame	R1–R2 → Frame		
2.	Starting winding to Frame	S1–S2 → Frame		
3.	Running winding to Starting winding	R1–R2 → S1–S2		

02. Dielectric Strength Test:

Sr. No.	Test	Observations Parameters	Remarks (Yes/No)
1.	High Voltage test (Test voltage 1000 V for a motor of 250 V)	Burning Smell	
		Sparking	
		Excessive heat	
		Any other	
		None of the above	

XVI. References/Suggestions for further reading:

1. www.electrical4u.com
2. www.electricaltechnology.org
3. www.bis.org.in
4. <https://electricaltopic.com/Single-phase-motor-test-with-megger.html>

Assessment Scheme:

Performance Indicators		Weightage
Process Related: (15 Marks)		60%
1	Handling of the components	10 %
2	Identification of component	20 %
3	Measuring value using suitable instrument	20 %
4	Working in team	10 %
Product Related: (10 Marks)		40%
5	Identify theoretical values of given component from datasheets	10 %
6	Interpretation of result	05 %
7	Conclusions	05 %
8	Practical related questions	15 %
9	Submitting the journal in time	05%
Total (25 Marks)		100 %

Marks Obtained			Dated signature of Teacher
Process Related (15)	Product Related (10)	Total (25)	

Practical No. 22: Test insulation resistance and dielectric strength of the windings of a three-phase induction motor.

I. Practical Significance:

The test is conducted to check the condition and strength of insulation between the windings and the motor frame. It helps in detecting moisture, deterioration, or faults in insulation, ensuring the safe and reliable operation of the three-phase induction motor.

II. Industry/Employer Expected Outcome(s)

To develop the ability to evaluate the insulation health of motor windings, interpret insulation resistance and dielectric strength test results, and ensure the electrical safety and reliability of induction motors as required in industrial maintenance and testing practices.

III. Course Level Learning Outcome(s)

CO5 - Maintain insulation systems of electrical equipment.

IV. Laboratory Learning Outcome(s)

LLO 22.1 Insulation resistance and dielectric strength of the windings in a three-phase induction motor by applying high-voltage, ensuring that the motor can withstand operational voltage without failure

V. Relevant Affective Domain related outcome(s)

To develop a responsible and safety-conscious attitude while performing high-voltage electrical tests, and to follow standard testing procedures and safety practices with accuracy, care, and professionalism during motor insulation testing.

VI. Relevant Theoretical Background (With diagrams if required)

The insulation resistance test and dielectric strength test are performed to determine the condition and quality of insulation between the windings and between the windings and the motor frame in a three-phase induction motor.

In the insulation resistance test, a megger (insulation tester) applies a DC voltage (usually 500 V or 1000 V) across the winding and measures the resistance in megaohms (M Ω). A high resistance value indicates good insulation, while a low value indicates moisture, dirt, or insulation deterioration.

In the dielectric strength test, a high AC voltage (usually twice the rated voltage + 1000 V) is applied between the windings and the motor frame for a specified time (generally 1 minute) to check the insulation's ability to withstand high voltage without breakdown.

These tests help ensure safe operation, prevent short circuits, and verify that the motor meets industrial insulation and safety standards before commissioning or after maintenance. The insulation resistance test and dielectric strength test are performed to determine the condition and

quality of insulation between the windings and between the windings and the motor frame in a three-phase induction motor.

In the insulation resistance test, a megger (insulation tester) applies a DC voltage (usually 500 V or 1000 V) across the winding and measures the resistance in megaohms (MΩ). A high resistance value indicates good insulation, while a low value indicates moisture, dirt, or insulation deterioration.

In the dielectric strength test, a high AC voltage (usually twice the rated voltage + 1000 V) is applied between the windings and the motor frame for a specified time (generally 1 minute) to check the insulation's ability to withstand high voltage without breakdown.

These tests help ensure safe operation, prevent short circuits, and verify that the motor meets industrial insulation and safety standards before commissioning or after maintenance.

VII. Actual Circuit diagram used in laboratory with equipment Specifications:

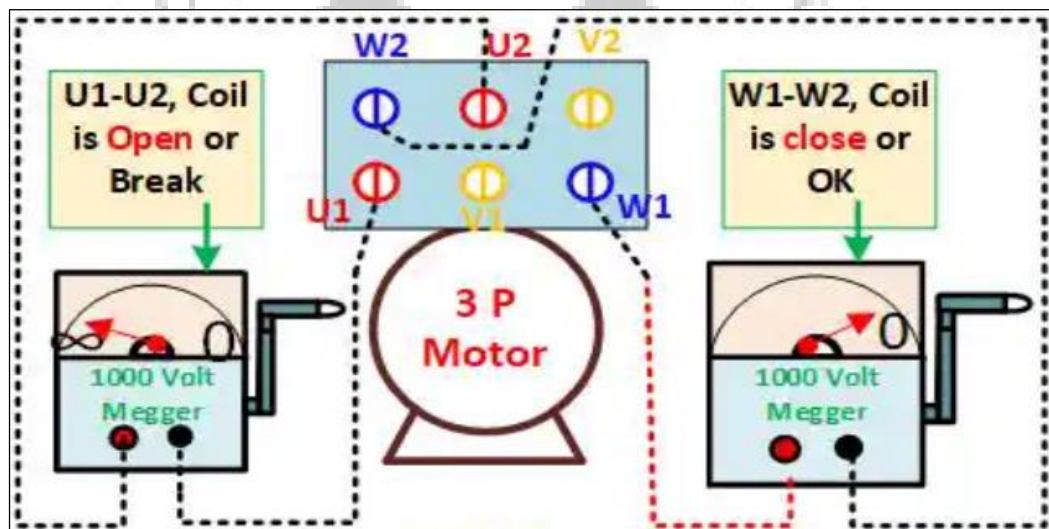

Fig. 22.1 Insulation resistance test on single phase induction motor

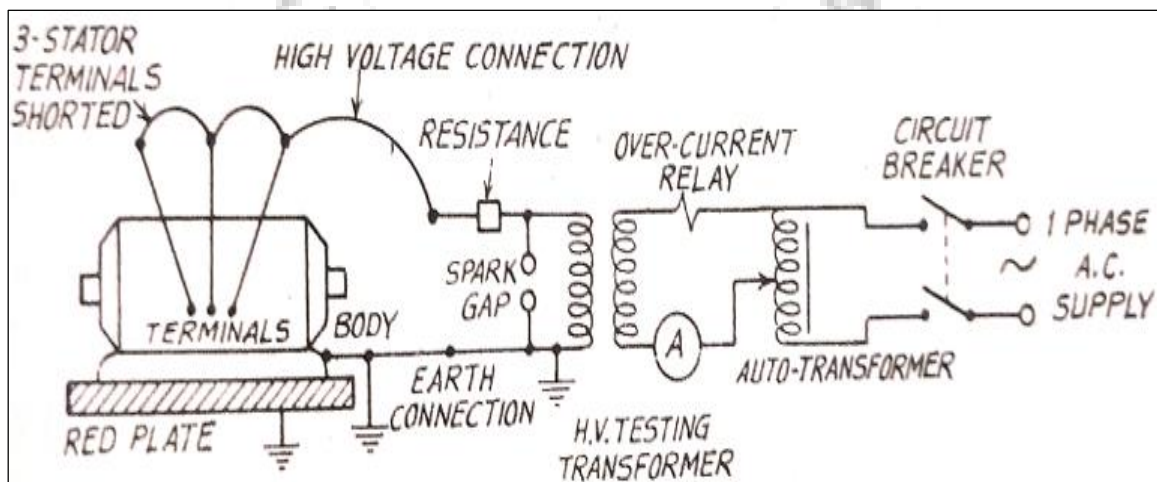

Fig. 22.2 Dielectric Strength Test

VIII. Required Resources/apparatus/equipment with specification:

Sr. No.	Name of Resource	Suggested Broad Specification	Quantity
1.	Megger	1000 V	01 No.
2.	HV Tester	230 V/1000 V	01 No.
3.	1-PH Induction motor	1 HP	01 No.
4.	Ammeter	0-20 A AC	01 No.
5.	Connecting Probes	As per standard	-

IX. Precautions to be followed:**Insulation resistance test**

- Ensure the motor is disconnected from the power supply.
- Clean and dry the motor terminals before testing.
- Use a megger with proper test voltage (usually 1000 V DC).
- Do not touch terminals or leads during the test.
- Test each winding separately from the frame and from each other.
- Apply test voltage only for a few seconds.
- Discharge the winding after testing.
- Record insulation resistance values properly.

Dielectric Strength Test

- Disconnect the motor from the power supply.
- Check test equipment and leads for insulation and calibration.
- Keep windings and terminals clean and dry.
- Use proper test voltage as per motor rating.
- Make firm and secure connections.
- Do not touch terminals during high-voltage testing.
- Increase voltage gradually and maintain for 1 minute.
- Stop test immediately if breakdown occurs.
- Discharge windings after testing.
- Keep the test area dry and isolated.

X. Procedure:**Insulation resistance test**

- Connect the megger red lead to any one phase terminal (e.g., R).
- Connect the megger black lead to the motor frame (body).
- Operate the megger by rotating its handle (manual type) or pressing the test button (digital type).
- Note down the insulation resistance value (in $M\Omega$).
- Repeat the same steps for the Y–Frame and B–Frame connections.
- Each phase-to-frame resistance should be greater than 1 $M\Omega$ (preferably 5 $M\Omega$ or higher).

Dielectric Strength Test

- Make the connections as per diagram.
- Initially apply one third of test voltage at power frequency.
- Increase the voltage in steps of 5% of test voltage with time interval of ten seconds.
- Increase the voltage up to test value and maintain it for one minute.
- Reduce the voltage suddenly to one third of test voltage and switch off.

XI. Observations and calculations

01. Insulation resistance Test

Sr. No.	Test Conducted	Terminals Connected	Measured Insulation Resistance (MΩ)	Remarks (OK/Fail)
1.	Phase Windings	U1-U2		
2.		W1-W2		
3.		V1-V2		
4.	Windings to Frame	U-Frame		
5.		W-Frame		
6.		V-Frame		

02. Dielectric Strength Test

Sr. No.	Test	Observations Parameters	Remarks (Yes/No)
1.	High Voltage test (Test voltage 1000 V for a motor of 250 V)	Burning Smell	
		Sparking	
		Excessive heat	
		Any other	
		None of the above	

XII. Results:

.....

.....

.....

.....

XIII References/Suggestions for further reading:

1. www.electrical4u.com
2. www.electricaltechnology.org
3. www.bis.org.in

Assessment Scheme:

Performance Indicators		Weightage
Process Related: (15 Marks)		60%
1	Handling of the components	10 %
2	Identification of component	20 %
3	Measuring value using suitable instrument	20 %
4	Working in team	10 %
Product Related: (10 Marks)		40%
5	Identify theoretical values of given component from datasheets	10 %
6	Interpretation of result	05 %
7	Conclusions	05 %
8	Practical related questions	15 %
9	Submitting the journal in time	05%
Total (25 Marks)		100 %

Marks Obtained			Dated signature of Teacher
Process Related (15)	Product Related (10)	Total (25)	

Practical No.23: Measurement of insulation resistance of single-phase induction motor.

I. Practical Significance:

Measuring the insulation resistance of a single-phase induction motor ensures the health of the motor windings and prevents electrical hazards.

II. Industry/Employer Expected Outcome(s):

Ensure safe and reliable operation of single-phase induction motors in industrial and domestic applications. Enable predictive maintenance to reduce downtime and increase motor efficiency and lifespan.

III. Course Level Learning Outcome (s):

CO5 - Maintain insulation systems of electrical equipment.

IV. Laboratory Learning Outcome(s):

LLO 23.1 Measure insulation resistance of single-phase induction motor.

V. Relevant Affective Domain Related Outcome(s):

Develop safety awareness and responsibility while working with electrical machines and high-voltage testing equipment. Cultivate precision and conscientiousness in performing measurements and recording results accurately.

VI. Relevant Theoretical Background:

Insulation in Motors:

Electrical motors consist of windings made of copper or aluminium wire, which must be insulated from each other and from the motor frame to prevent short circuits. The insulation material (such as enamel, varnish, or fiberglass) resists the flow of current between live conductors and earth. Over time, insulation can degrade due to moisture, dust, heat, mechanical stress, or chemical exposure, leading to leakage currents or motor failure.

Insulation Resistance:

Insulation resistance is the measure of how well the motor windings resist leakage current. It is expressed in mega-ohms ($M\Omega$). High insulation resistance indicates healthy windings, while low resistance indicates deterioration or contamination. Measuring insulation resistance helps identify potential failures before they cause serious damage.

Importance in Single-Phase Induction Motors:

Single-phase induction motors are widely used in household appliances, fans, pumps, and small industrial machines. They rely on good insulation for safe operation because the entire motor operates on a single-phase supply. Leakage currents due to poor insulation can cause shocks, short circuits, or motor burnout.

Testing Principle Using Megger:

A Megger (Insulation Resistance Tester) applies a high DC voltage (commonly 500 V DC for low-voltage motors) between the winding and the motor frame. The current that flows through

the insulation is extremely small, and the Megger measures the resistance. The reading gives a direct indication of the insulation condition:

- **High resistance ($\geq 10 \text{ M}\Omega$)** → Good insulation
- **Moderate resistance (5–10 $\text{M}\Omega$)** → Abnormal, monitor condition
- **Low resistance ($< 2 \text{ M}\Omega$)** → Poor insulation, requires maintenance.

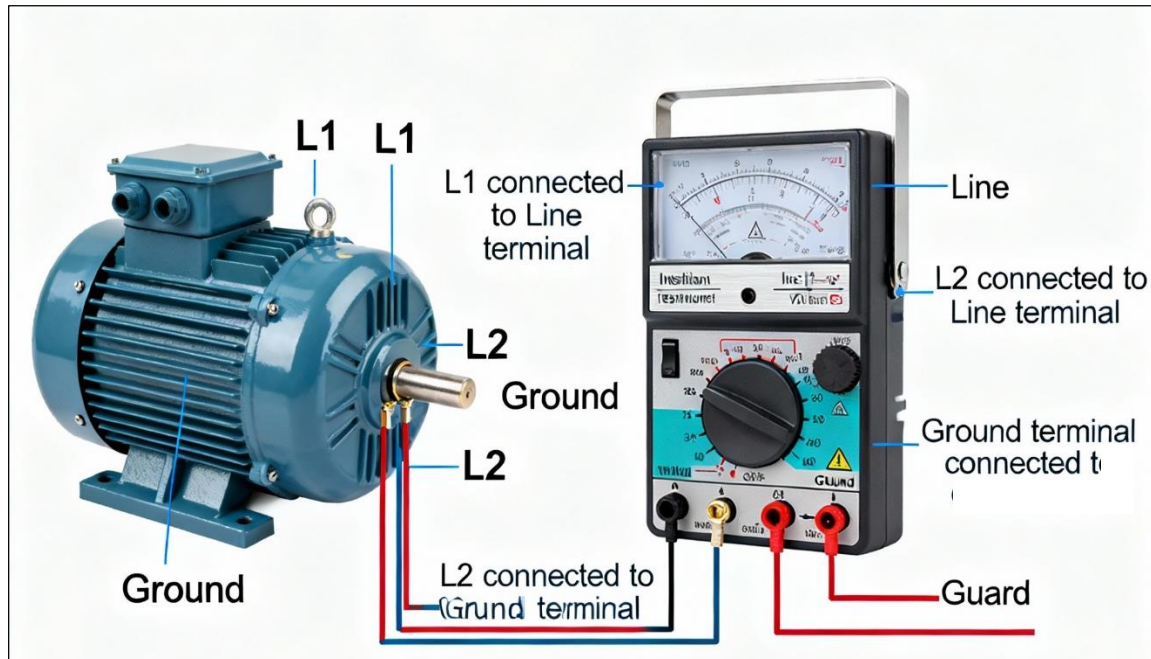

Fig. 23.2 Measurement of insulation resistance of motor

Factors Affecting Insulation Resistance:

- **Temperature:** Higher temperatures reduce insulation resistance.
- **Moisture & Humidity:** Moisture reduces resistance drastically.
- **Age of Motor:** Insulation naturally deteriorates over time.
- **Contaminants:** Dust, oil, and chemical deposits can decrease insulation resistance.

Standards and Safety Guidelines:

- As per IS 2992, a new low-voltage motor should have insulation resistance $\geq 1 \text{ M}\Omega$.
- Measurement should always be done with the motor disconnected from supply and using proper PPE.
- Regular insulation testing is an important predictive maintenance practice to avoid motor failure and ensure safe operation.

VII. Circuit Diagram:

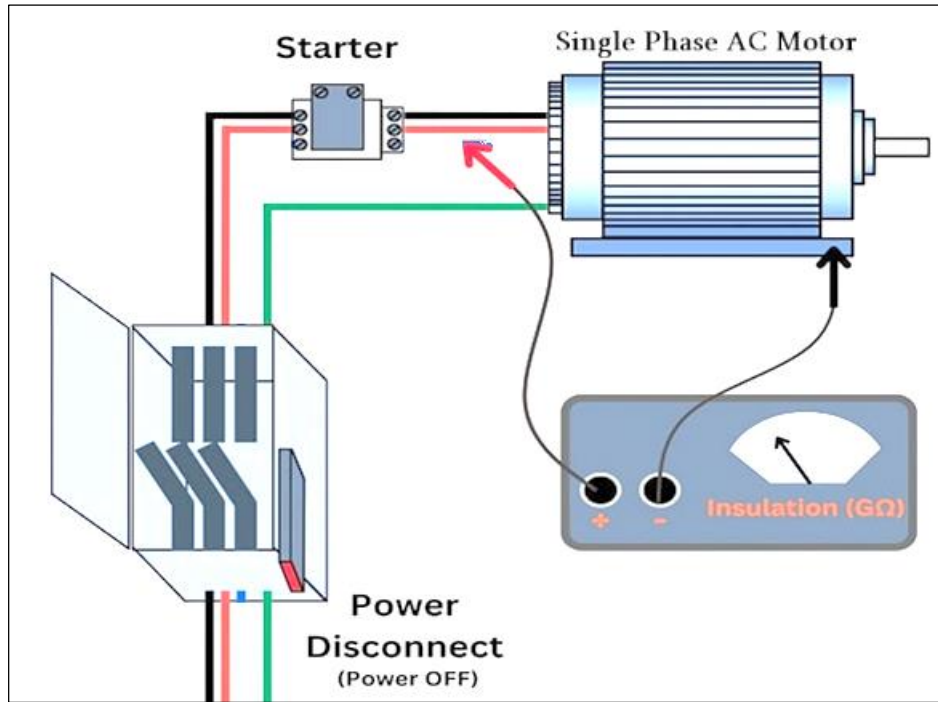

Figure 23.1 Measurement of insulation resistance of motor

VIII. Required Resources/apparatus/equipment with specification.:

Sr. No.	Equipment / Apparatus	Specification / Rating	Quantity
1.	Single phase induction motor.	1 HP / 3 HP , 230 V, 50 Hz, single phase induction motor	1 No.
2.	Insulation Resistance Tester (Megger)	Hand-operated or Digital type, 500 V / 1000 V DC range	1 No.
3.	Connecting Leads	Insulated, High Voltage Grade	As Required
4.	Personal Protective Equipment (PPE)	Insulated Gloves, Safety Goggles, Shoes	As Required

IX. Precaution:

1. Ensure that the motor is completely disconnected from the mains supply before testing.
2. Do not touch the megger terminals or motor winding connections while the test is in progress.
3. Make sure that all terminals are clean and tightened properly to ensure accurate measurement.
4. Perform the test for only the required duration (usually 10–60 seconds) to prevent insulation stress.

X. Procedure:

1. Ensure the motor is disconnected from the power supply.

Maintenance of Electrical Equipments (316328)

2. Wear safety gloves and follow laboratory safety rules.
3. Clean the motor terminals and windings to remove dust, dirt, or moisture.
4. Select the test voltage on the insulation tester (megger), usually 500V or 1000V DC.
5. Connect one lead of the megger to the motor winding terminal.
6. Connect the other lead of the megger to the motor frame / earth.
7. Measure Start Winding to Earth: Apply megger voltage and note the reading in $M\Omega$.
8. Measure Run Winding to Earth: Repeat the procedure for the run winding.
9. Measure Start to Run Winding: Connect megger between start and run winding terminals and record the reading.
10. Record all insulation resistance values in the observation table.
11. Mention any abnormal readings or insulation deterioration in the "Status / Remarks" column.

XI. Observation Table:

Sr. No.	Phase / Measurement	Insulation Resistance ($M\Omega$)	Status / Remarks
1.	Start Winding to Earth		
2.	Run Winding to Earth		
3.	Start to Run Winding		

XII. Results:

.....

.....

.....

.....

XIII. Interpretation of results:

.....

.....

.....

.....

XIV. Conclusion and recommendation:

.....

.....

.....

.....

XVI. References/Suggestions for further reading:

1. <https://control.com/technical-articles/how-do-you-megger-a-motor-understanding-motor-insulation-resistance/>
2. IS 7816: Guide for Testing of AC Induction Motors
– Covers insulation resistance and dielectric strength testing methods.
3. Electrical Machine Textbooks (e.g., B.L. Theraja, P.S. Bimbhra)
– Contain theoretical background on motor insulation systems.
4. <https://electricalblogging.com/single-phase-induction-motor/>

Assessment Scheme:

Performance Indicators		Weightage
Process Related: (15 Marks)		60%
1	Handling of the components	10 %
2	Identification of component	20 %
3	Measuring value using suitable instrument	20 %
4	Working in team	10 %
Product Related: (10 Marks)		40%
5	Identify theoretical values of given component from datasheets	10 %
6	Interpretation of result	05 %
7	Conclusions	05 %
8	Practical related questions	15 %
9	Submitting the journal in time	05%
Total (25 Marks)		100 %

Marks Obtained			Dated signature of Teacher
Process Related (15)	Product Related (10)	Total (25)	

Practical No.24: Measurement of insulation resistance of three phase induction motor.

I. Practical Significance:

The insulation resistance test of a three-phase induction motor is essential to ensure the reliability and safety of the motor before operation. It helps in detecting insulation deterioration caused by factors like moisture, dust, aging, or thermal stress, thereby preventing short circuits and electrical failures.

II. Industry/Employer Expected Outcome(s):

- Student should be able to perform insulation resistance testing using a megger safely.
- Student should identify insulation faults and interpret test results effectively.

III. Course Level Learning Outcome (s):

CO5 Maintain insulation systems of electrical equipment.

IV. Laboratory Learning Outcome(s):

LLO 24.1 Measure insulation resistance of three phase induction motor.

V. Relevant Affective Domain Related Outcome(s):

Develops safety consciousness while handling electrical equipment. Demonstrates responsibility in maintaining proper testing procedures. Exhibits teamwork and cooperation during practical performance. Shows a positive attitude toward preventive maintenance and quality work.

VI. Relevant Theoretical Background:

Insulation resistance is the resistance offered by insulation material between motor windings and the motor frame (earth). It indicates the health and quality of the motor's insulation system. The test is carried out using a megger act as a high-resistance range ohm meter. A DC voltage of 500V or 1000V is applied between the winding under test and earth (motor frame). The insulation resistance value is read directly on the tester in megaohms (M Ω). The motor must be disconnected from supply and discharged before testing. During and immediately after the test, do not touch any motor terminal, as dangerous voltages may remain. The minimum insulation resistance is measured at winding temperature between -15°C and 20°C . The maximum insulation resistance is observed at operating temperatures between 80°C and 120°C , depending on motor type and efficiency. Insulation resistance decreases as temperature increases. As a rule of thumb, insulation is considered good if $IR \geq 10 \text{ M}\Omega$. If the reading is below this value, the insulation may be moist, dirty, or deteriorated.

Factors affecting insulation resistance include:

- Temperature of windings
- Moisture and humidity
- Dust and oil on the surface
- Age and operating conditions of the motor.

VII. Circuit Diagram:

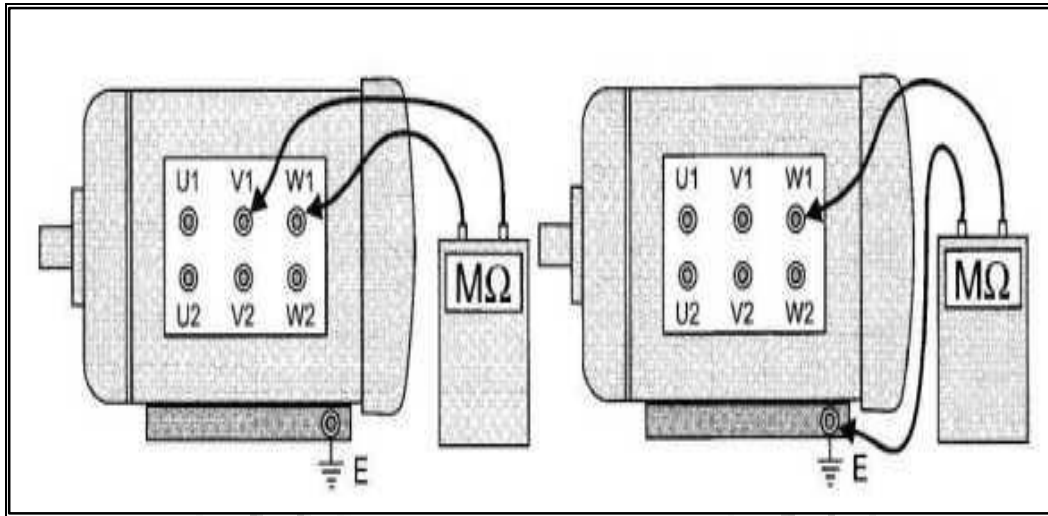

Fig. 23.1 Measurement of insulation resistance of 3 phase IM

VIII. Required Resources/apparatus/equipment with specification.

Sr. No.	Equipment / Apparatus	Specification / Rating	Quantity
1.	Three phase induction motor.	3-phase 3 HP / 5HP , 400 V, 50 Hz, 1500 RPM squirrel cage induction motor	1 No.
2.	Insulation Resistance Tester (Megger)	Hand-operated or Digital type, 500 V / 1000 V DC range	1 No.
3.	Connecting Leads	Insulated, High Voltage Grade	As Required
4.	Personal Protective Equipment (PPE)	Insulated Gloves, Safety Goggles, Shoes	As Required

IX. Precautions to be followed:

- Ensure the motor is completely disconnected from the power supply before testing.
- Lockout/tagout the supply to prevent accidental switching on.
- Discharge any capacitors or residual voltage in the motor windings before connecting the tester.
- Avoid using a voltage higher than recommended for small motors.
- Use properly insulated leads and probes; ensure firm connections to motor terminals and frame.
- Do not touch the motor terminals, leads, or tester while the test voltage is applied.
- Wear insulated gloves, safety goggles, and stand on an insulating mat during the test.
- Avoid testing in wet or damp areas; keep the surrounding area free from flammable materials.

X. Procedure:

1. Disconnect the motor from the power supply and remove motor terminal covers.
2. Inspect the Megger, leads, and probes for damage.
3. Wear insulated gloves, safety goggles, and stand on an insulating mat.
4. Connect one lead of the Megger to phase terminal L1 and the other to motor frame (earth).
5. Set the Megger to the appropriate test voltage (e.g., 500 V DC).
6. Operate the Megger and allow the reading to stabilize.
7. Record the insulation resistance for L1–Earth.
8. Repeat steps 4–7 for L2–Earth and L3–Earth.
9. Optionally, measure phase-to-phase insulation resistance (L1–L2, L2–L3, L1–L3).
10. Compare readings with standard values to evaluate insulation condition.
11. Short-circuit motor terminals to discharge any residual voltage.
12. Disconnect the Megger and store all equipment safely.

XI. Observation Table:

Sr No.	Phase / Measurement	Insulation Resistance (MΩ)	Status / Remarks
1.	L1 – Earth		
2.	L2 – Earth		
3.	L3 – Earth		
4.	L1 – L2 (Phase-to-Phase)		
5.	L2 – L3 (Phase-to-Phase)		
6.	L1 – L3 (Phase-to-Phase)		

XII. Results:

.....

.....

.....

.....

XIII. Interpretation of results:

.....

.....

.....

.....

XVI. References/Suggestions for further reading:

1. <https://www.electrical4u.com/measurement-of-insulation-resistance/>
2. Electrical Technology – B.L. Theraja, A.K. Theraja, S. Chand & Company Ltd.
3. https://www.powerpro.ng/blogs/news/insulation-resistance-test-of-a-three-phase-induction-motor?srsltid=AfmBOoqmRmZBBT-D_BF7cs7w-CBc4wUDrml7O7TGunkbcUcQZ-JnU0zP.
4. <https://www.testandmeasurementtips.com/basics-motor-testing/>

Assessment Scheme:

Performance Indicators		Weightage
Process Related: (15 Marks)		60%
1	Handling of the components	10 %
2	Identification of component	20 %
3	Measuring value using suitable instrument	20 %
4	Working in team	10 %
Product Related: (10 Marks)		40%
5	Identify theoretical values of given component from datasheets	10 %
6	Interpretation of result	05 %
7	Conclusions	05 %
8	Practical related questions	15 %
9	Submitting the journal in time	05%
Total (25 Marks)		100 %

Marks Obtained			Dated signature of Teacher
Process Related (15)	Product Related (10)	Total (25)	

Practical No.25: Measurement of insulation resistance of single-phase transformer.

I. Practical Significance:

The measurement of insulation resistance in a single-phase transformer is an essential test to ensure the safety, reliability, and performance of the transformer.

II. Industry/Employer Expected Outcome(s):

Students will be able to test and evaluate the insulation quality of transformer windings using a megger. They will develop the ability to identify insulation faults or deterioration and ensure safe and reliable operation of electrical equipment in industrial applications.

III. Course Level Learning Outcome(s):

CO5- Maintain insulation systems of electrical equipment.

IV. Laboratory Learning Outcome(s):

LLO 25.1 Measure insulation resistance of single-phase transformer.

V. Relevant Affective Domain related outcome(s):

Develops awareness of the importance of insulation testing in maintaining electrical system reliability and safety.

VI. Relevant Theoretical Background:

The insulation resistance measurement of a single-phase transformer is an important test to ensure the safety, reliability, and performance of the equipment. The purpose of this test is to check the quality of insulation between the transformer windings and between winding and core. Proper insulation prevents leakage current, short circuits, and electric shocks.

When a transformer is in operation, the windings are subjected to high voltage stresses. Over time, due to factors such as moisture, temperature variations, dust, mechanical vibrations, and aging, the insulation may deteriorate. This degradation can lead to current leakage and eventually to insulation failure. To detect such issues before serious damage occurs, the insulation resistance test is performed.

The principle of insulation resistance measurement is based on Ohm's Law,

$$R = \frac{v}{i}$$

where:

- R = Insulation Resistance (in MΩ)
- V = Applied DC Voltage (in Volts)
- I = Leakage Current (in Amperes)

A Megger (insulation tester) is used to apply a high DC voltage (typically 500V, 1000V, or 2500V depending on the rating of the transformer) across the insulation. The instrument

measures the small leakage current that flows through the insulation and directly indicates the insulation resistance value in megohms (MΩ).

VII. Circuit Diagram:

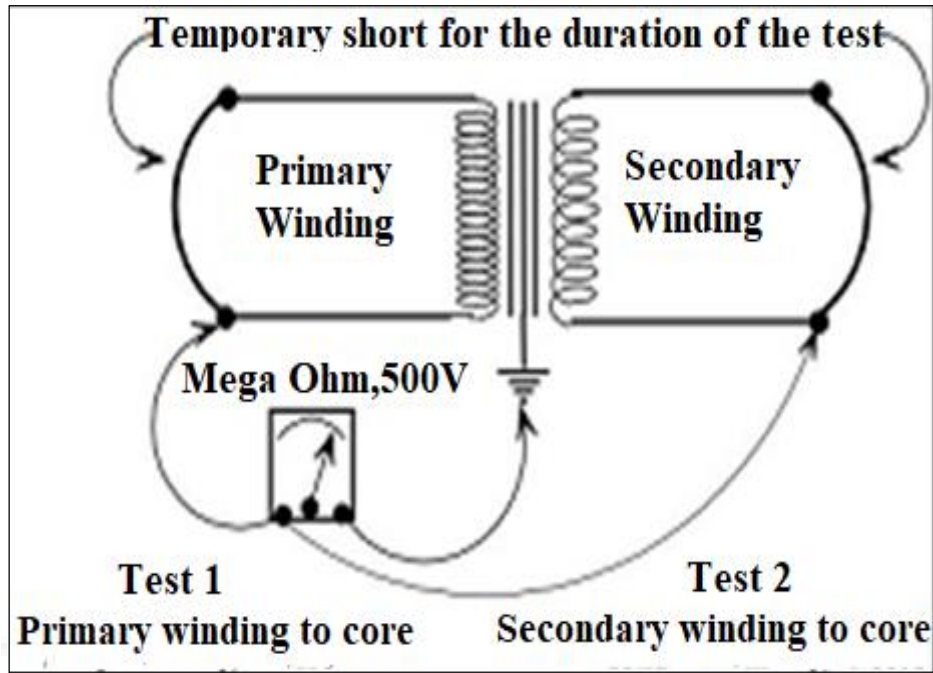

Figure 25.1 : Insulation resistance testing of single-phase transformer

VIII. Required Resources/apparatus/equipment with specification.

Sr. No.	Equipment / Apparatus	Specification / Rating	Quantity
1.	Single Phase Transformer	230 V / 115 V, 1 kVA	1 No.
2.	Insulation Resistance Tester (Megger)	Hand-operated or Digital type, 500 V / 1000 V DC range	1 No.
3.	Connecting Leads	Insulated, High Voltage Grade	As Required
4.	Personal Protective Equipment (PPE)	Insulated Gloves, Safety Goggles, Shoes	As Required

IX. Precautions to be followed:

1. Ensure the transformer is completely disconnected from the power supply before testing.
2. Always discharge the transformer windings after the test.
3. Use insulated gloves and safety goggles while performing the test.
4. Check the condition of the Megger and test leads before use.

5. Perform the test under dry and clean conditions.
6. Avoid direct contact with live terminals and test leads.
7. Select the appropriate test voltage according to transformer specifications.
8. Ensure tight and secure connections to prevent incorrect readings.
9. Handle the transformer and instruments carefully to avoid damage.
10. Follow the step-by-step procedure strictly for safety and accuracy.

X. Procedure:

1. Ensure the transformer is completely disconnected from the power supply.
2. Discharge all transformer windings to remove any residual voltage.
3. Clean transformer terminals and windings if required.
4. Connect the megger between Primary and Secondary winding terminals and note the insulation resistance.
5. Connect the megger between Primarywinding and Earth (Body) and record the reading.
6. Connect the megger between Secondary winding and Earth (Body) and note the insulation value.
7. Select the appropriate test voltage on the insulation tester according to transformer rating.
8. Apply the test voltage gradually and observe the insulation resistance reading on the tester.
9. Hold the test voltage for about 1 minute to stabilize the reading.
10. Record the insulation resistance value for each winding.
11. Discharge the transformer windings after testing.
12. Disconnect the insulation tester and restore transformer connections if required.
13. Enter all readings in the observation table.

XI. Observation table:

Transformer Rating: -KVA

Sr. No.	Test Points	Insulation Resistance (MΩ)	Remarks / Condition of Insulation
1	Between Primary & Secondary		
2	Primary– Earth (Body)		
3	Secondary– Earth (Body)		

XII. Results:

.....

.....

.....

.....

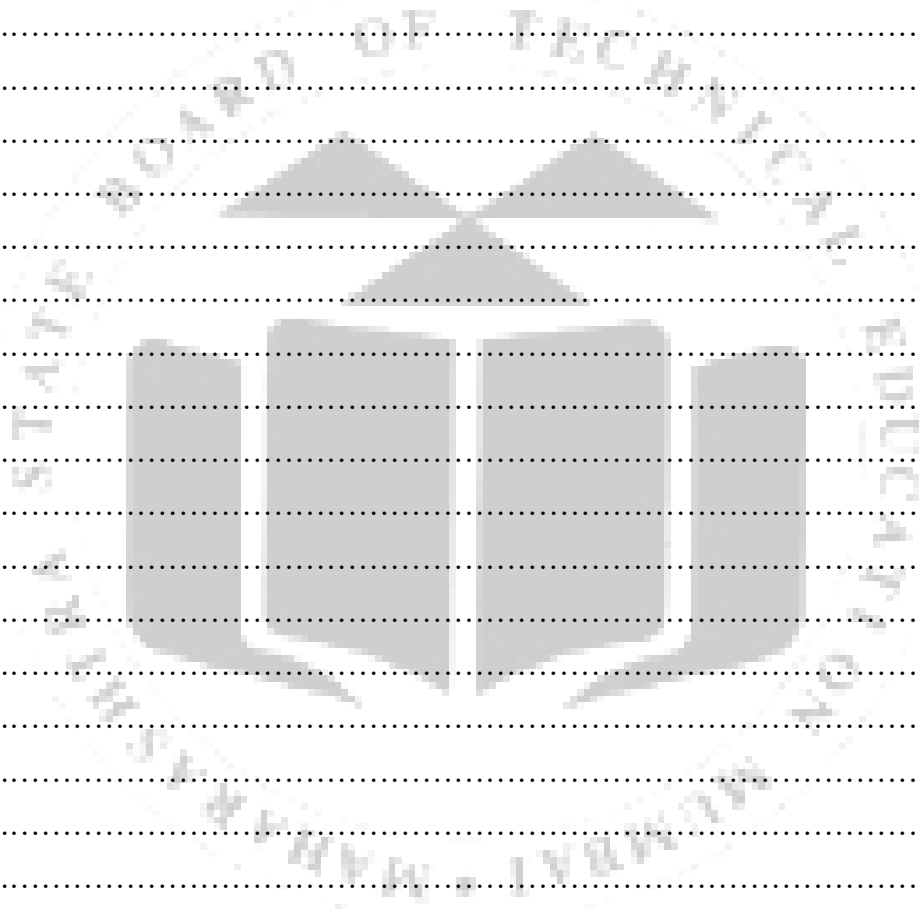

XVI. References/Suggestions for further reading:

1. <https://www.electrical4u.com/measurement-of-insulation-resistance/>
2. Electrical Technology – B.L. Theraja, A.K. Theraja, S. Chand & Company Ltd.
3. https://onlinecourses.swayam2.ac.in/nou24_ee001/preview

Assessment Scheme:

Performance Indicators		Weightage
Process Related: (15 Marks)		60%
1	Handling of the components	10 %
2	Identification of component	20 %
3	Measuring value using suitable instrument	20 %
4	Working in team	10 %
Product Related: (10 Marks)		40%
5	Identify theoretical values of given component from datasheets	10 %
6	Interpretation of result	05 %
7	Conclusions	05 %
8	Practical related questions	15 %
9	Submitting the journal in time	05%
Total (25 Marks)		100 %

Marks Obtained			Dated signature of Teacher
Process Related (15)	Product Related (10)	Total (25)	

Practical No.26: Measurement of insulation resistance of three phase transformer.

I Practical Significance:

Measuring the insulation resistance of a three-phase transformer helps detect faults, moisture, or deterioration in windings. It ensures safe operation, reliability, and prolongs the transformer’s service life.

II Industry/Employer Expected Outcome(s):

Ability to perform insulation testing of transformers as part of preventive maintenance. Skill in interpreting insulation resistance readings to ensure reliable and safe transformer operation.

III Course Level Learning Outcome(s):

CO5- Maintain insulation systems of electrical equipment.

IV Laboratory Learning Outcome(s):

LLO 26.1 Measure insulation resistance of three phase transformers.

V Relevant Affective Domain related outcome(s):

- Develop safety-conscious behaviour while handling high-voltage equipment.
- Exhibit responsibility and precision in maintenance and testing tasks.

VI Relevant Theoretical Background:

- Insulation resistance is the resistance offered by insulating materials to current leakage.
- Low insulation resistance may indicate moisture, dirt, aging, or breakdown of insulation.
- Megger (insulation tester) applies a DC voltage to measure insulation resistance in mega ohms (MΩ).
- Maintaining high insulation resistance ensures transformer reliability, reduces downtime, and prevents electrical hazards.

VII Circuit Diagram:

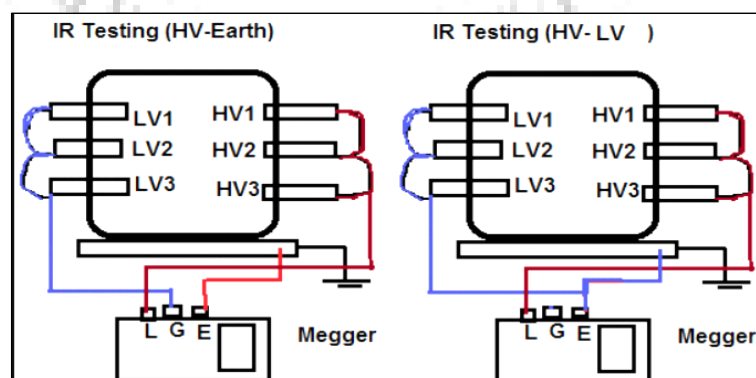

Fig. 26.1 Measurement of insulation resistance of three phase transformer

VIII Required Resources/apparatus/equipment with specification.

Sr. No.	Equipment / Apparatus	Specification / Rating	Quantity
1.	Three-Phase Transformer	400V/230V, 50 Hz, 3-phase transformer, range of 2 kVA to 4 kVA.	1 No.
2.	Insulation Resistance Tester (Megger)	500 V / 1000 V DC Range / Analog or Digital	1 No.
3.	Connecting Leads	Insulated, High Voltage Grade	As Required
4.	Personal Protective Equipment (PPE)	Insulated Gloves, Safety Goggles, Shoes	As Required
5.	Earthing Rod / Clip	Proper Grounding Connection	1 No.

IX Precautions to be followed:

1. Ensure the transformer is completely switched off, isolated, and discharged before testing.
2. Do not touch test terminals or exposed conductors during measurement.
3. Use proper PPE such as insulated gloves, safety goggles, and shoes.
4. Connect the megger leads securely to avoid sparking or false readings.
5. Apply only the recommended test voltage as per the transformer rating.
6. Keep the work area dry and free from conductive materials.

X Procedure:

1. Switch off and isolate the transformer from the power supply.
2. Discharge all transformer windings to earth before testing.
3. Identify the HV (High Voltage) and LV (Low Voltage) terminals.
4. Set the insulation tester (megger) to the appropriate voltage range (e.g., 500V / 1000V DC).
5. Connect the megger between **HV and LV terminals** and note the insulation resistance.
6. Connect the megger between **HV and Earth (Body)** and record the reading.
7. Connect the megger between **LV and Earth (Body)** and note the insulation value.
8. After each test, discharge the terminals to ground to remove residual charge.
9. Enter all readings in the observation table.

XI Observation table:
Transformer Rating: -KVA

Sr. No.	Test Points	Insulation Resistance (MΩ)	Remarks / Condition of Insulation
1	HV – LV		
2	HV – Earth (Body)		
3	LV – Earth (Body)		

XII Results:

.....

.....

.....

.....

XIII Interpretation of results:

.....

.....

.....

.....

XIV Conclusion and recommendation:

.....

.....

.....

.....

XV Practical related questions (Provide space for answers):

(Note: Below given are few sample questions for reference. Teachers must design more such questions so as to ensure the achievement of identified CO.)

1. What is the purpose of measuring insulation resistance in a transformer?
2. What readings indicate good insulation? How do you interpret the Megger reading?
3. Why is insulation resistance measured in transformers?
4. What does a low insulation resistance indicate?

.....

.....

.....

.....

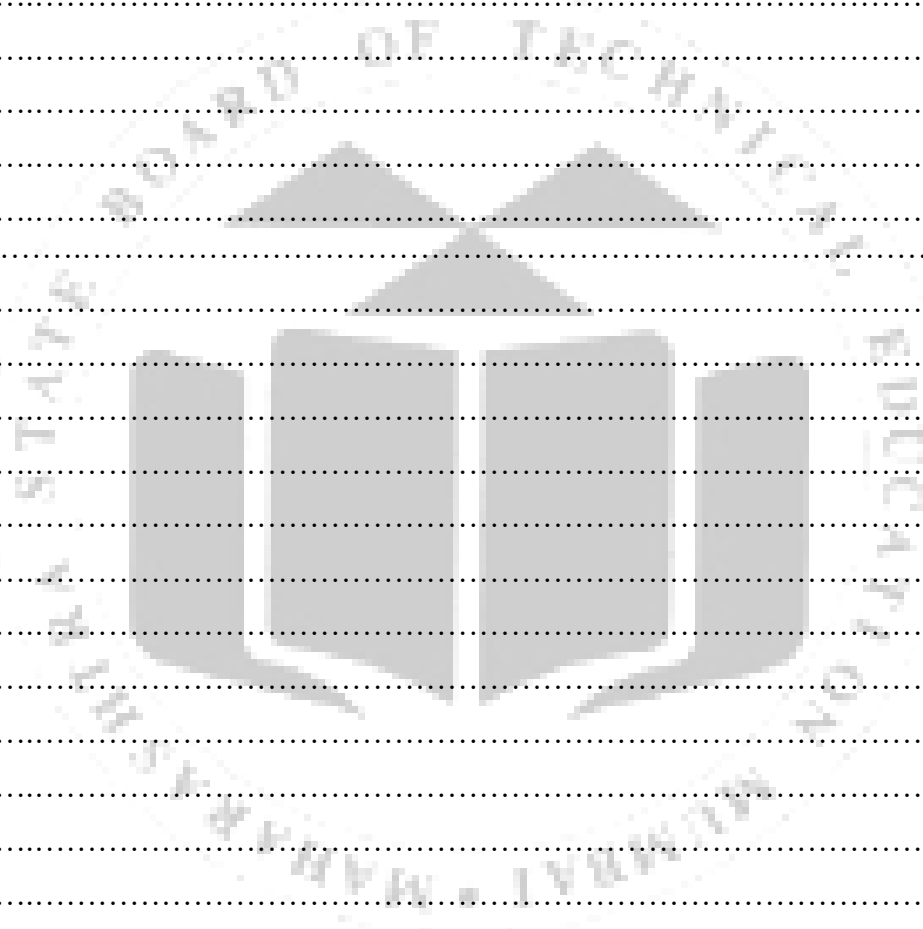

XVI References/Suggestions for further reading:

1. S.K. Bhattacharya, Electrical Machines, Tata McGraw-Hill Education.
2. Nagrath I.J. & Kothari D. P. Electric Machines, Tata McGraw-Hill Education.
3. ABB Technical Guide No. 5, Testing of Electrical Machines – Insulation Resistance and Polarization Index.
4. IS: 2026 (Part I-V), Specification for Power Transformers, Bureau of Indian Standards.
5. IS: 7816 – 1975, Code of Practice for Measurement of Insulation Resistance of Electrical Machines.

Assessment Scheme:

Performance Indicators		Weightage
Process Related: (15 Marks)		60%
1	Handling of the components	10 %
2	Identification of component	20 %
3	Measuring value using suitable instrument	20 %
4	Working in team	10 %
Product Related: (10 Marks)		40%
5	Identify theoretical values of given component from datasheets	10 %
6	Interpretation of result	05 %
7	Conclusions	05 %
8	Practical related questions	15 %
9	Submitting the journal in time	05%
Total (25 Marks)		100 %

Marks Obtained			Dated signature of Teacher
Process Related (15)	Product Related (10)	Total (25)	